





SECTION 4 HARDWARE

AWNING	172-205
GROMMETS	206-209
FINISHING SUPPLIES FOR WEBBING	209-213
FASTENERS	213-215
MARINE	216-251
TENT AND TARP	252-257
ZIPPERS	257-269
TOOLS	269-281

POLYFAB™ PRO SHADE SAIL HARDWARE

This premium line of marine grade AISI 316/304 stainless steel and other steel hardware is recommended for use in tension shade structures such as hip and ridge and tension membrane shade sails in conjunction with HDPE knitted shade cloth or equivalent quality fabric. The finished structure needs to be properly engineered by a professional engineer and installed by a qualified contractor in accordance with local building codes.

It is the responsibility of the fabricator within these parameters to determine the proper hardware for a particular installation.

WARRANTY	5-Year
-----------------	--------

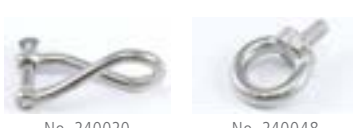
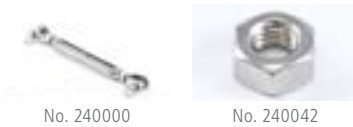

ITEM #	STYLE #	DESCRIPTION	FOR	MATERIAL	PUT UP	SIZE	THREADED FOR SIZE
240000	SS-TBJJ-08	Polyfab Pro Turnbuckle Jaw/Jaw		AISI 316 Stainless Steel	1/each	8 mm	M8
240001	SS-TBJJ-10	Polyfab Pro Turnbuckle Jaw/Jaw		AISI 316 Stainless Steel	1/each	10 mm	M10
240002	SS-TBJJ-12	Polyfab Pro Turnbuckle Jaw/Jaw		AISI 316 Stainless Steel	1/each	12 mm	M12
240005	SS-TBEE-08	Polyfab Pro Turnbuckle Eye/Eye		AISI 316 Stainless Steel	1/each	8 mm	M8
240006	SS-TBEE-10	Polyfab Pro Turnbuckle Eye/Eye		AISI 316 Stainless Steel	1/each	10 mm	M10
240007	SS-TBEE-12	Polyfab Pro Turnbuckle Eye/Eye		AISI 316 Stainless Steel	1/each	12 mm	M12
240008	SS-TBST-12	Polyfab Pro Closed-Body Turnbuckle with Swivel Toggle Ends		AISI 316 Stainless Steel	1/each	12mm (1/2")	M12
240009	SS-TBST-16	Polyfab Pro Closed-Body Turnbuckle with Swivel Toggle Ends		AISI 316 Stainless Steel	1/each	16mm (5/8")	M12
240010	SS-SBF-08	Polyfab Pro Shackle Bow		AISI 316 Stainless Steel	1/each	8 mm	M8
240011	SS-SBF-10	Polyfab Pro Shackle Bow		AISI 316 Stainless Steel	1/each	10 mm	M10
240012	SS-SBF-12	Polyfab Pro Shackle Bow		AISI 316 Stainless Steel	1/each	12 mm	M12
240013	SS-SD-08	Polyfab Dee Shackle		AISI 316 Stainless Steel	1/each	8 mm	M8
240014	SS-SD-10	Polyfab Dee Shackle		AISI 316 Stainless Steel	1/each	10 mm	M10
240015	SS-SD-08	Polyfab Long Dee Shackle		AISI 316 Stainless Steel	1/each	8 mm	M8
240016	SS-SD-10	Polyfab Long Dee Shackle		AISI 316 Stainless Steel	1/each	10 mm	M10
240020	SS-SLT-08	Polyfab Long Twisted Shackle		AISI 316 Stainless Steel	1/each	8 mm	M8
240021	SS-SLT-10	Polyfab Long Twisted Shackle		AISI 316 Stainless Steel	1/each	10 mm	M10
240030	SS-EYN-12	Polyfab Pro Eye Nut		AISI 316 Stainless Steel	1/each	12 mm	M12
240031	SS-EYB-08120	Polyfab Pro Eye Bolt, Nut, 2 Washers		AISI 316 Stainless Steel	1/each	8 x 120 mm	M8
240032	SS-EYB-10120	Polyfab Pro Eye Bolt, Nut, 2 Washers		AISI 316 Stainless Steel	1/each	10 x 120 mm	M10
240033	SS-LNN-08	Polyfab Pro Nylon Lock Nuts		AISI 316 Stainless Steel	1/each	8 mm	M8
240034	SS-LNN-10	Polyfab Pro Nylon Lock Nuts		AISI 316 Stainless Steel	1/each	10 mm	M10
240035	SS-LNN-12	Polyfab Pro Nylon Lock Nuts		AISI 316 Stainless Steel	1/each	12 mm	M12
240036	SS-EYNB-10100	Polyfab Pro Eye Nut Bolt, Nut, Washer		AISI 316 Stainless Steel	1/each	10 x 100 mm	M10
240037	SS-EYNB-10600	Polyfab Pro Eye Nut Bolt, Nut, Washer		AISI 316 Stainless Steel	1/each	10 x 160 mm	M10
240038	SS-EYNB-12200	Polyfab Pro Eye Nut Bolt, Nut, Washer		AISI 316 Stainless Steel	1/each	12 x 200 mm	M12
240040	SS-TRI-06	Polyfab Pro Triangle		AISI 316 Stainless Steel	1/each	6 x 50 mm	M6
240041	SS-TRI-08	Polyfab Pro Triangle		AISI 316 Stainless Steel	1/each	8 x 50 mm	M8
240042	SS-HN-08	Polyfab Pro Hex Nut		AISI 316 Stainless Steel	1/each	8 mm	M8
240044	SS-EYN-08	Polyfab Pro Eye Nut		AISI 316 Stainless Steel	1/each	8 mm	M8
240045	SS-DRG-06	Polyfab Pro Dee Ring		AISI 316 Stainless Steel	1/each	6 x 50 mm	
240046	SS-DRG-08	Polyfab Pro Dee Ring		AISI 316 Stainless Steel	1/each	8 x 50 mm	
240047	SS-EYN-10	Polyfab Pro Eye Nut		AISI 316 Stainless Steel	1/each	10 mm	M10
240048	SS-EYBC-08	Polyfab Pro Eye Bolt with Collar		AISI 316 Stainless Steel	1/each	8 mm	M8
240049	SS-EYBC-10	Polyfab Pro Eye Bolt with Collar		AISI 316 Stainless Steel	1/each	10 mm	M10
240050	SS-DRHD-05	Polyfab Pro Easy-Hold Dee Ring		AISI 316 Stainless Steel	1/each	5 x 50 mm	
240051	SS-DRHD-08	Polyfab Pro Easy-Hold Dee Ring		AISI 316 Stainless Steel	1/each	8 x 50 mm	
240053	SS-EYBC-12	Polyfab Pro Eye Bolt with Collar		AISI 316 Stainless Steel	1/each	12 mm	M12
240054	SS-EYNB-12120	Polyfab Pro Eye Nut Bolt, Nut, Washer		AISI 316 Stainless Steel	1/each	12 x 120mm	M12
240055	SS-DRTH-650	Polyfab Pro Dee Ring Tumble		AISI 316 Stainless Steel	1/each	6 x 50 mm	
240056	SS-DRTH-850	Polyfab Pro Dee Ring Tumble		AISI 316 Stainless Steel	1/each	8 x 50 mm	
240057	SS-DRTH-1065	Polyfab Pro Dee Ring Tumble		AISI 316 Stainless Steel	1/each	10 x 65 mm	
240059	SS-WRT-03	Polyfab Pro Thimble		AISI 316 Stainless Steel	1/each	3.2 mm	
240061	SS-WRT-06	Polyfab Pro Thimble		AISI 316 Stainless Steel	1/each	6 mm	
240062	SS-WRT-08	Polyfab Pro Thimble		AISI 316 Stainless Steel	1/each	8 mm	
240063	SS-WRT-10	Polyfab Pro Thimble		AISI 316 Stainless Steel	1/each	10 mm	
240064	SS-EYNB-12150	Polyfab Pro Eye Nut Bolt, Nut, Washer		AISI 316 Stainless Steel	1/each	12 x 150mm	M12
240065	SS-WRC-04	Polyfab Pro Rope Clamp		AISI 316 Stainless Steel	1/each	4 mm	
240066	SS-WRC-06	Polyfab Pro Rope Clamp		AISI 316 Stainless Steel	1/each	6 mm	
240067	SS-WRC-08	Polyfab Pro Rope Clamp		AISI 316 Stainless Steel	1/each	8 mm	
240069	SS-HN-10	Polyfab Pro Hex Nut		AISI 316 Stainless Steel	1/each	10 mm	M10
240070	NP-WRS-04	Polyfab Pro Swaging Sleeve		Nickel Plated Copper	1/each	4 mm	
240071	NP-WRS-06	Polyfab Pro Swaging Sleeve		Nickel Plated Copper	1/each	6 mm	
240072	NP-WRS-08	Polyfab Pro Swaging Sleeve		Nickel Plated Copper	1/each	8 mm	
240073	SS-WRC-10	Polyfab Pro Rope Clamp		AISI 316 Stainless Steel	1/each	10 mm	
240074	SS-WRC-03	Polyfab Pro Rope Clamp		AISI 316 Stainless Steel	1/each	3.2 mm	
240075	HS-345CR	Croc Heavy Duty Hand Swage Tool for 3, 3.2, 4, 5mm Wire	3, 3.2, 4 and 5 mm wire		1/each		



No. 240076



No. 240102



No. 240084



No. 240103



No. 240090



No. 240104



No. 240094



No. 240105



No. 240095



No. 240106



No. 240097



No. 240114



No. 240100



No. 240115



No. 240101

ITEM #	STYLE #	DESCRIPTION	FOR	MATERIAL	PUT UP	SIZE	THREADED FOR SIZE
240076	HS-6810CR	Croc Heavy Duty Hand Swage Tool for 6, 8, 10mm Wire	6, 8, and 10 mm wire		1/each		
240077	NP-WRS-03	Polyfab Pro Swaging Sleeve		Nickel Plated Copper	1/each	3.2 mm	
240078	SS-WR719-03	Polyfab Pro Shade Sail Wire Rope 7x19		AISI 316 Stainless Steel	250 ft. reel	3.2 mm / 1/8 in.	
240079	SS-WR719-03	Polyfab Pro Shade Sail Wire Rope 7x19		AISI 316 Stainless Steel	1000 ft. reel	3.2 mm / 1/8 in.	
240080	ZN-CBEX-100	Polyfab Pro External Corner Bracket		Zinc Plated Steel	1/each	100 mm	
240081	ZN-CBIN-100	Polyfab Pro Internal Corner Bracket		Zinc Plated Steel	1/each	100 mm	
240082	ZN-CBEX-100120	Polyfab Pro External Corner Bracket		Zinc Plated Steel	1/each	100 x 120 mm	
240083	ZN-CBEX-250	Polyfab Pro External Corner Bracket		Zinc Plated Steel	1/each	250 mm	
240084	ZN-CBIN-250	Polyfab Pro Internal Corner Bracket		Zinc Plated Steel	1/each	250 mm	
240085	SS-WR719-06	Polyfab Pro Shade Sail Wire Rope 7x19		AISI 316 Stainless Steel	250 ft. reel	6 mm / 1/4 in.	
240086	SS-WR719-06	Polyfab Pro Shade Sail Wire Rope 7x19		AISI 316 Stainless Steel	1000 ft. reel	6 mm / 1/4 in.	
240087	SS-WR719-08	Polyfab Pro Shade Sail Wire Rope 7x19		AISI 316 Stainless Steel	250 ft. reel	8 mm / 5/16 in.	
240088	SS-WR719-08	Polyfab Pro Shade Sail Wire Rope 7x19		AISI 316 Stainless Steel	1000 ft. reel	8 mm / 5/16 in.	
240089	SS-WR719-10	Polyfab Pro Shade Sail Wire Rope 7x19		AISI 316 Stainless Steel	250 ft. reel	10 mm / 3/8 in.	
240090	ZN-WPD-100	Polyfab Pro Diagonal Eye Wall Plate		Zinc Plated Steel	1/each	100 mm	
240091	ZN-WPD-150	Polyfab Pro Diagonal Eye Wall Plate		Zinc Plated Steel	1/each	150 mm	
240092	SS-WR719-10	Polyfab Pro Shade Sail Wire Rope 7x19		AISI 316 Stainless Steel	1000 ft. reel	10 mm / 3/8 in.	
240094	SS-WPD-180	Polyfab Pro Diamond Wall Plate with 100mm Shackle Eye		AISI 316 Stainless Steel	1/each	180 x 110 mm	
240095	SS-PED-90	Polyfab Pro Diamond Pad Eye		AISI 316 Stainless Steel	1/each	80 mm	
240096	SS-PED-100	Polyfab Pro Diamond Pad Eye		AISI 316 Stainless Steel	1/each	100 mm	
240097	SS-SC-15	Polyfab Pro Safety Cable		AISI 316 Stainless Steel	1/each		
240100	ZN-FBTH	Polyfab Pro Fascia Bracket with 12mm Threaded Rod		Zinc Plated Steel	1/each		
240101	ZN-FBLH	Polyfab Pro Fascia Bracket for 20 Degree Rafter Angle Left		Zinc Plated Steel	1/each		
240102	ZN-FBRH	Polyfab Pro Fascia Bracket for 20 Degree Rafter Angle Right		Zinc Plated Steel	1/each		
240103	ZN-FB90	Polyfab Pro Fascia Bracket for Flat Roof		Zinc Plated Steel	1/each		
240104	ZN-FB2W	Polyfab Pro Fascia Bracket Two Way		Zinc Plated Steel	1/each		
240105	AL-DISK-06	Polyfab Pro Corner Disk Assembly		Stamped Aluminum	1/each		
240106	SS-HKS-08	Polyfab Pro Spring Hook		AISI 316 Stainless Steel	1/each	8 mm	
240107	SS-HKS-10	Polyfab Pro Spring Hook		AISI 316 Stainless Steel	1/each	10 mm	
240108	SS-QLT-06	Polyfab Pro Triangle Quick Link		AISI 316 Stainless Steel	1/each	6 mm	
240109	SS-QLT-10	Polyfab Pro Triangle Quick Link		AISI 316 Stainless Steel	1/each	10 mm	
240110	SS-WRT-05	Polyfab Pro Thimble		AISI 316 Stainless Steel	1/each	5 mm	
240111	SS-WRC-05	Polyfab Pro Rope Clamp		AISI 316 Stainless Steel	1/each	5 mm	
240112	NP-WRS-05	Polyfab Pro Swaging Sleeve for 5mm Wire		Nickel Plated Copper	1/each	5 mm	
240113	ZN-CBEX-150	Polyfab Pro External Corner Bracket		Zinc Plated Steel	1/each	150 mm	
240114	ZN-CBIN-150	Polyfab Pro Internal Corner Bracket		Zinc Plated Steel	1/each	150 mm	
240115	ZN-CBIN-100120	Polyfab Pro Internal Corner Bracket		Zinc Plated Steel	1/each	100 x 120 mm	

Polyfab™ is a trademark of Polyfab USA.



POLYFAB™ SHADE SAIL EDGE WEBBING

Polyfab Shade Sail Edge Webbing is used for shade structures and shade sails. This polyester webbing has a breaking strength of approximately 4,700 pound force. Available in 20 colors to match Polytex®, Comtex® and Architec 400® extra heavy duty knitted Shadecloth.

ITEM #	COLOR	COLOR NUMBER	PUT UP	WIDTH
565101	Midnight Green	62	109 yd.	2 in.
565103	Blue	50	109 yd.	2 in.
565105	Navy Blue	51	109 yd.	2 in.
565107	Sandstone	73	109 yd.	2 in.
565109	Bronze	81	109 yd.	2 in.
565111	Sage	19	109 yd.	2 in.
565113	Charcoal	92	109 yd.	2 in.
565115	Porcelain	71	109 yd.	2 in.
565117	Yellow	10	109 yd.	2 in.
565121	Black	99	109 yd.	2 in.
565125	Silver Gray	91	109 yd.	2 in.
565127	Red	30	109 yd.	2 in.
565129	Beige	72	109 yd.	2 in.
565131	Café Noir	35	109 yd.	2 in.
565133	White	01	109 yd.	2 in.
565135	Antec Orange	22	109 yd.	2 in.
565137	Berry	36	109 yd.	2 in.
565139	Purple	58	109 yd.	2 in.
565141	Fluoro Green	67	109 yd.	2 in.

Polyfab™ is a trademark of Polyfab USA. Polytex®, Comtex® and Architec 400® are registered trademarks of Polyfab USA.



No. 240022



No. 240024



No. 240052



No. 240058

POLYFAB™ TRIAX™ CANOPY FRAME SYSTEM

The Polyfab Triax Canopy Frame System available exclusively from Trivantage® allows fabricators to build freestanding or attached canopy frames that support water resistant covers in either residential or commercial settings. The system consists of aluminum cast fittings that connect in a cradle-fashion with bolts or Tek® screws to standard 2 3/8 inch steel tubing. Tension on the cover is held within the frame, making it possible to create free standing or attached canopies that shed water and avoid over stressing the anchor structure. Assembly does not require welding, which means less equipment at the job site and the ability to use standard galvanized aluminum tubing.

Triax is ideal for residential projects such as gracefully curved patio awnings and side-yard car shade areas. It is also designed for use on commercial buildings, such as restaurant decks, building entrances and school courtyards. In public spaces, the system can be sized to provide shade for small areas such as park picnic tables and larger expanses such as swimming pools.

It is the responsibility of the fabricator within these parameters to determine the proper hardware for a particular installation.

ITEM #	STYLE #	DESCRIPTION	FOR	MATERIAL	SIZE
240022	AL-T50	Polyfab Triax Fitting	2-3/8 in. tubing		
240023	AL-PC80	Polyfab Triax Post Cap	3-1/2 in. tubing		
240024	PE-TUIN	Polyfab Triax Tubing Insert	2-3/8 in. tubing		
240025	SS-EYTB-08120	Polyfab Triax Eye Tube Bolt		AISI 316 Stainless Steel	8 x 120 mm
240026	SS-EYTB-10045	Polyfab Triax Eye Tube Bolt		AISI 316 Stainless Steel	10 x 45 mm
240027	SS-EYTB-10075	Polyfab Triax Eye Tube Bolt		AISI 316 Stainless Steel	10 x 75 mm
240028	SS-THJR-08	Polyfab Triax Right Thread Jaw with Nut		AISI 316 Stainless Steel	8 x 57 mm
240029	SS-THJR-10	Polyfab Triax Right Thread Jaw with Nut		AISI 316 Stainless Steel	10 x 68 mm
240043	SS-EYS-10	Polyfab Triax Screw Eye		AISI 316 Stainless Steel	10 x 80 mm
240052	SS-DRHD-10	Polyfab Triax Easy-Hold Dee Ring		AISI 316 Stainless Steel	10 mm
240058	SS-RTH-1150	Polyfab Triax Round Thimble		AISI 316 Stainless Steel	11 x 50 mm

Polyfab™ and Triax™ are trademarks of Polyfab USA. Tek® is a registered trademark of Illinois Tool Works, Inc. Trivantage® is a registered trademark of Glen Raven, Inc.

MISTING SYSTEM – MIST-ER-COMFORT™ OUTDOOR CUSTOM BOAT KIT WITH PUMP AND TANK

Do your customers love the outdoors, but hate being hot? You can offer them the perfect solution with Mist-er-Comfort outdoor misting systems. These easy to install systems attach to any boat bimini top or patio structure to provide hours of comfort during hot days.

Mist-er-Comfort for boats installs in minutes and uses a boat’s water supply for hours of cool mist, which can drop temperatures by up to 25 degrees. Your marine customers can use it to keep cool while fishing on the flats, idling through no-wake zones, anchored in calm waters, docked at the marina or beached at their favorite island.

The 2001 kit comes completely assembled with three misting heads, 6 mounting straps, 28 feet of polyethylene tubing, through-floor insert special 1/2 inch t-adapter kit, on/off valve, automatic drain valve.

The 2011 kit includes 2 feet of tubing, one misting head and a mounting strap.

The 2003-SS kit includes a 125psi pump/filter/automatic drain, 4 stainless steel mister heads, 35 feet of polyethylene tubing, mounting options of VELCRO® straps or grommets to conceal misting heads in hard top or T-top. Console on/off switch not included.

The 2004-SS kit comes with a completely assembled 6 gallon pump/tank controlled by a switch (switch not included), 125psi pump/filter/automatic drain, fill tank by simply removing cap on top of tank 4 stainless steel mister heads, 35 feet of polyethylene tubing, mounting options of VELCRO® straps or grommets to conceal misting heads in hard top or T-top.

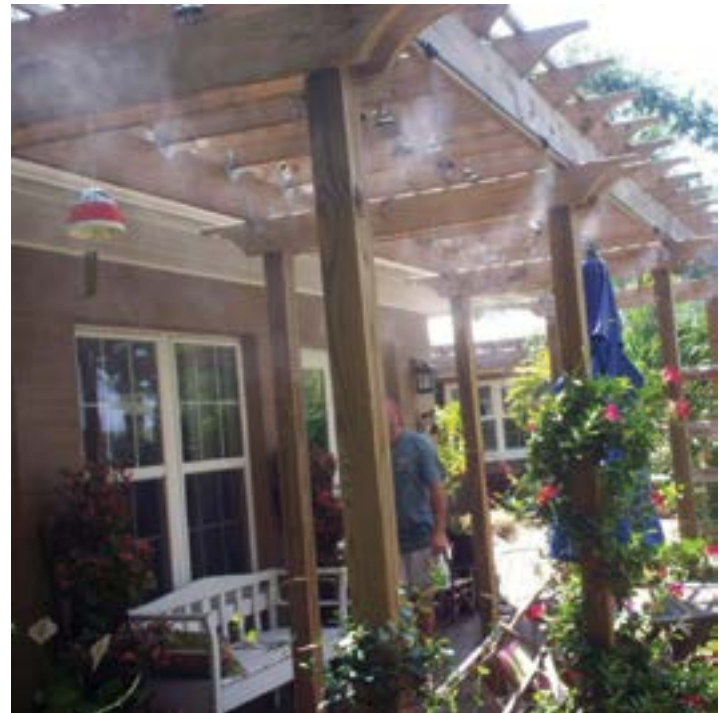

MISTING SYSTEM – MIST-ER-COMFORT™ OUTDOOR STANDARD PATIO MISTER KIT

The Mist-er-Comfort Patio Mister forms a curtain-like barrier, separating patio from the surrounding hot areas. On a hot summer day, Mist-er-Comfort can drop the outdoor temperature by up to 25 degrees around backyard patios and pool areas, as well as outdoor decks and restaurants. Each patio misting kit comes with mounting hardware to install on wood fascia, siding, handrail, or decking.

The standard portable misting patio kit consists of six misting heads spaced every four feet, providing over 20 feet of comfortable misting area. Misting heads can be easily added for larger applications. Use caution not to exceed the recommended number of misting heads based on water pressure.

Standard Patio Mister Kit includes six mister heads, 12 wood staples, 40 feet of polyethylene tubing, a garden hose adapter, an on/off valve, and a screen mesh filter.

ITEM #	STYLE #	DESCRIPTION
277774	4001	Patio Misting Kit

Mist-er Comfort™ is a trademark of Mist-er-Comfort, Inc.

ITEM #	STYLE #	DESCRIPTION
277770	2001	Marine Misting Kit
277771	2011	Marine Misting Head Kit
277772	2003-SS	Marine Misting Kit with Pump
277773	2004-SS	Misting Kit with Pump/Tank

Mist-er Comfort™ is a trademark of Mist-er-Comfort, Inc. VELCRO® is a registered trademark of Velcro Industries B.V.

MISTING SYSTEM – MIST-ER-COMFORT™ OUTDOOR PATIO BOOSTER PUMP KIT

The Patio Booster Pump Kit is recommended if household water pressure does not meet the PSI requirements. The Kit includes a 125psi pump, on/off switch, control valve, water filter, and an automatic drain valve, all enclosed in a weatherproof locking cabinet.

ITEM #	STYLE #	DESCRIPTION
277779	4013	Patio Booster Pump Kit

Mist-er Comfort™ is a trademark of Mist-er-Comfort, Inc.

MISTING SYSTEM – MIST-ER-COMFORT™ OUTDOOR PATIO MISTER OPTIONS

Patio Mister Options include additional mister heads (includes 6 feet of tubing, one misting head and mounting hardware), a garden hose adapter, a UV clip, and a VELCRO® strap.

ITEM #	STYLE #	DESCRIPTION
277775	4011	Patio Misting Head Kit
277776	4080	Misting Garden Hose Adapter
277777	4056	Patio Misting UV Clip
277778	4057	Patio Misting Velcro Strap

Mist-er Comfort™ is a trademark of Mist-er-Comfort, Inc. VELCRO® is a registered trademark of Velcro Industries B.V.



No. 112630

AWNING HARDWARE – HEAD ROD CLAMP – NARROW BASE TYPE – ZINC DIE CAST

A fixture designed for attaching the head rod of an awning to various building surfaces, as well as providing hooks for hanging awning pulleys. Plated, zinc die-cast.

One countersunk hole for wood screw provides quick and solid installation. Furnished with machine bolt and wing nut.

ITEM #	STYLE #	SIZE HEAD ROD	STANDARD PACKAGE
112630*	30Z	1/2 in. diameter iron	25

*112630 - Also available in aluminum.



No. 112510

AWNING HARDWARE – HEAD ROD CLAMP – ROLLER CURTAIN TYPE – MALLEABLE IRON

A fixture designed for attaching the head rod of an awning to various building surfaces, as well as providing hooks for hanging awning pulleys.

Plated, malleable iron. Fastens on inside of porch so that pulleys and pull ropes are on inside of curtain. Can be attached to either face board or ceiling.

ITEM #	STYLE #	FOR	SIZE HEAD ROD	STANDARD PACKAGE
112510	10	Brick	3/8 in. or 1/2 in. diameter iron	25
112521	21	Wood	3/8 in. or 1/2 in. diameter iron	25



No. 112521

AWNING HARDWARE – ELBOW

Plated, malleable iron. Threaded.

ITEM #	STYLE #	STANDARD PACKAGE	THREADED FOR PIPE SIZE
123002*	2	25	3/8 in.
123003*	3	25	1/2 in.
123004*	4	25	3/4 in.
123005	5	25	1 in.
123008	8	25	1/2 in. x 3/4 in.

*123002 - Also available in aluminum.

*123003 - Also available in aluminum.

*123004 - Also available in aluminum.



No. 123004

AWNING HARDWARE – HEAD ROD CLAMP – ZINC DIE CAST

A fixture designed for attaching the head rod of an awning to various building surfaces, as well as providing hooks for hanging awning pulleys. Plated, zinc die-cast.

ITEM #	STYLE #	FOR	SIZE HEAD ROD	STANDARD PACKAGE
112501	1	Wood	3/8 in. diameter iron	25
112504	4	Wood	1/2 in. diameter iron	25
112505	5	Wood	3/8 in. diameter iron	25
112509*	6	Wood	1/2 in. diameter iron	25

*112509 - Stainless steel fasteners.



No. 124702

AWNING HARDWARE – PIN OR NUT END

Plated, malleable Iron. Threaded and fitted with a nut. Use with side nut hinge or front cotter hinge.

ITEM #	STYLE #	STANDARD PACKAGE	THREADED FOR SIZE
124702	2	25	1/2 in. pipe



No. 112501



No. 112504



No. 112505



No. 112509



No. 124002

AWNING HARDWARE – EYE END – MALLEABLE IRON

Use with side nut hinge or front cotter hinge. Plated, malleable iron. Threaded. Placed on the ends of arms and rafters for fastening onto hinges or jaws.

ITEM #	STYLE #	STANDARD PACKAGE	THREADED FOR SIZE	TYPE
124002*	2	25	1/4 in. pipe or 1/2 in. iron	Small eye
124003*	3	25	3/8 in. pipe or 5/8 in. iron	Small eye
124004	4	25	1/2 in. pipe	Small eye
124005	5	25	3/4 in. pipe	Small eye
124007	7	25	1/4 in. pipe or 1/2 in. iron	Large eye
124009	9	25	1/2 in. pipe	Large eye
124010	10	25	3/4 in. pipe	Large eye
124012	12	25	1 in. pipe	Small eye

*124002 - Also available in aluminum.
 *124003 - Also available in aluminum.



No. 281680

AWNING HARDWARE – FRONT BAR CLAMP – ALUMINUM

Front bar clamps provide fast and complete slip fit of pipe rafter to front bar. Simply tighten the set screws which are furnished and the operation is complete.

ITEM #	STYLE #	FOR	STANDARD PACKAGE
281680	380-A	3/4 in. x 3/4 in. pipe	25
281681	381-A	1 in. x 1 in. pipe	25



No. 281530

AWNING HARDWARE – HEAD ROD CLAMP – FOR NARROW BASE INSTALLATION – ALUMINUM

One countersunk hole provided for wood screw. Extra strong aluminum bolts and non-ferrous zinc wing nuts.

ITEM #	STYLE #	FOR	STANDARD PACKAGE
281530	30A-40	1/2 in. rod	25



No. 281510

AWNING HARDWARE – HEAD ROD CLAMP – FOR BRICK OR STONE – ALUMINUM

Furnished with hole for 3/8 inch diameter lag. Includes machine screw and wing nuts.

ITEM #	STYLE #	FOR	STANDARD PACKAGE
281510	10A-4	1/2 in. rod	25



No. 281501

AWNING HARDWARE – HEAD ROD CLAMP – FOR WOOD – ALUMINUM

Furnished with two countersunk holes to accommodate No. 10 wood screws. Includes machine screw and wing nuts.



No. 281505

ITEM #	STYLE #	FOR	STANDARD PACKAGE
281501	03	3/8 in. rod	25
281505	5A-1	3/8 in. rod	25
281506	6A-2	1/2 in. rod	25



No. 281702

AWNING HARDWARE – CLEAT

Aluminum cleat for wood with two countersunk holes for wood screws.

ITEM #	STYLE #	FOR	LENGTH	STANDARD PACKAGE
281702	2A-2	3/4 in. pipe	6 in.	25



No. 281106

AWNING HARDWARE – EYE END – ALUMINUM

Threaded.

ITEM #	STYLE #	FOR	STANDARD PACKAGE
281106	5A	3/4 in. pipe	25
293616*	4A-4	1/2 in. pipe	25

*293616 - Also available in malleable iron.



No. 284093

AWNING HARDWARE – BRACKET HINGE – ALUMINUM

For wood. Two countersunk holes for wood screws. Furnished with machine screw. Also available in zinc die-cast.

ITEM #	STYLE #	PROJECTION	STANDARD PACKAGE
284093	OBA-3	1 in.	25



No. 286204

AWNING HARDWARE – SWIVEL EYE PULLEY – ALUMINUM DIE CAST

Aluminum die-cast with stainless steel pin.

ITEM #	STYLE #	ROPE DIAMETER	SHEAVE DIAMETER	STANDARD PACKAGE	STYLE SHEAVE
286204	1A	3/16 in.	1/2 in.	25	Single
286212	11A	3/16 in.	1/2 in.	25	Double



No. 286212



No. 157500

AWNING HARDWARE – SWIVEL EYE PULLEY – STAMPED

Stamped aluminum with an aluminum pin. Rustproof with smooth rounded top section housing to keep swivel eye from contact with rope. ABS plastic sheaves rotate freely on aluminum rivet.

ITEM #	STYLE #	ROPE DIAMETER	SHEAVE DIAMETER	STANDARD PACKAGE	STYLE SHEAVE
157500	60	1/8 in.	1/2 in.	100	Single
157501	61	3/16 in.	5/8 in.	100	Single
157502	62	3/16 in.	27/32 in.	100	Single

AWNING HARDWARE – SWIVEL EYE PULLEY – MALLEABLE IRON

Plated malleable iron.

ITEM #	STYLE #	ROPE DIAMETER	STANDARD PACKAGE	STYLE SHEAVE
266678	5	3/8 in.	50	Single



No. 284106

AWNING HARDWARE – ROD AND RAFTER HOLDERS – DUAL DUTY – ALUMINUM

Made to take 1/2 inch head rod. Designed to mount with either wood screws or lag bolt. Furnished with machine screws and wing nut.

ITEM #	STYLE #	FOR	STANDARD PACKAGE
284106	99A-99	1/2 in. rod	25



No. 284103

AWNING HARDWARE – ROD AND RAFTER HOLDERS – FOR BRICK OR WOOD – ALUMINUM

Rod and Rafter Holders furnished with machine screws and wing nut. Also available in iron.

ITEM #	STYLE #	FOR	STANDARD PACKAGE
284103	3A-89	1/2 in. rod	25



No. 281700

AWNING HARDWARE – SLIP-FIT TIE-DOWN CLAMP – ALUMINUM

Slip-fit tie-down clamps prevent water pockets behind the front bar. This clamp fastens to the front bar and holds a 3/8 inch pipe or 5/8 inch rod. Furnished with machine bolt and hex nut. Also available in steel.

ITEM #	STYLE #	FOR	STANDARD PACKAGE
281699	78	1 in. pipe	25
281700	77	3/4 in. pipe	25



No. 293412

AWNING HARDWARE – SLIP-FIT ELBOW

Furnished with socket head set screws.

ITEM #	STYLE #	FOR	NUMBER OF SET SCREWS	STANDARD PACKAGE
282004*	4-S	1/2 in. pipe	2	25
293410*	3-S	3/8 in. pipe	2	25
293412*	5-SQ	3/4 in. x 3/4 in. pipe	4	25
293413*	6-SQ	1 in. x 1 in. pipe	4	25

*282004 - Also available in malleable iron.

*293410 - Stainless steel set screws.

*293412 - Also available in malleable iron.

*293413 - Also available in malleable iron.



No. 282191

AWNING HARDWARE – SLIP-FIT EYE END – ALUMINUM

Furnished with socket head set screws.

ITEM #	STYLE #	FOR	STANDARD PACKAGE
282122*	2S	1/4 in. pipe	25
282190	290A-305	3/4 in. pipe	25
282191	291A-315	1 in. pipe	25
282193	286A-304	1/2 in. pipe	25

*282122 - Also available in malleable iron.



No. 287803

AWNING HARDWARE – SLIP-FIT ADJUSTABLE POST SOCKET – FOR BRICK – ALUMINUM

Furnished with square head set screw for slip-fit installation.

ITEM #	STYLE #	PIPE	STANDARD PACKAGE
287803	3A-205L	3/4 in. Slip-Fit	25
287804	4A-206L	1 in. Slip-Fit	25



No. 288144

AWNING HARDWARE – SLIP-FIT RAFTER AND UPRIGHT TEES

Designed for quick and efficient slip-fit installation at rafter and front bar.

Connect No. 600 and No. 601 slip tees to create corners. These rafter and upright slip tees for 1 inch Schedule 40 pipe are adjustable to 90°. Use interchangeable No. 600's together for other areas. All slip tees are furnished with stainless steel set screws.



No. 288147

ITEM #	STYLE #	FOR	STANDARD PACKAGE
288144*	600	1 in. x 1 in. pipe	25
288147	601	1 in. x 1 in. pipe	25

*288144 - Replaces the 53A-311 and 43A-312.



No. 283902

AWNING HARDWARE – SPEAR HEAD – ALUMINUM

Spear head with male threaded ends.

ITEM #	STYLE #	LENGTH	STANDARD PACKAGE	THREADED FOR PIPE SIZE
283902	2A-103	8-1/2 in.	25	1/2 in. male thread



No. 112847

AWNING HARDWARE – PIPE CLAMP – WROUGHT STEEL

Plated. Designed for a carriage bolt to prevent bolt head from turning when nut is tightened. Bolt included unless stated otherwise.

ITEM #	STYLE #	DESCRIPTION	BOLT SIZE	PIPE	STANDARD PACKAGE
112833	43	Bolt excluded	5/16 in.	3/4 in.	25
112834	44	Bolt excluded	5/16 in.	1 in.	25
112842	42	Bolt included	5/16 in.	1/2 in.	25
112843	43	Bolt included	5/16 in.	3/4 in.	25
112844	44	Bolt included	5/16 in.	1 in.	25
112847	42	Bolt included	3/8 in.	1/2 in.	25
112848	43	Bolt included	3/8 in.	3/4 in.	25
112849	44	Bolt included	3/8 in.	1 in.	25



No. 113234



No. 113236

AWNING HARDWARE – SLIP-FIT TIE-DOWN CLAMP

Trivantage® Slip-Fit fittings, made of sturdy, plated, shockproof malleable iron, or plated steel as shown, offer a time and labor saving way to install patio awnings. No threading necessary, as all fittings simply slip on or over pipe frame, and are then secured by means of square head set screws. Slip-Fit fittings permit rapid adjustment when pipe is not cut to exact length.

Plated, stamped steel with stainless steel bolt. Tie-down clamps are designed to eliminate pocketing of rain water on stationary or terrace awnings. Their use permits stationary awning covers to be drawn taut. Assembly can be made quickly on new stationary awning frames as well as old ones. Furnished with carriage bolt and hex nut.

ITEM #	STYLE #	FRONT BAR SIZE	STANDARD PACKAGE
113233	33	3/4 in. pipe	25
113234	34	1 in. pipe	25
113235	35	1-1/4 in. pipe	25
113236*	34A	1 in. pipe	25

*113236 - The longer projection of this pipe clamp allows the installer to pull the fabric tighter on the frame. A 2-1/4 inch tabling must be used on the 34A for the installer to achieve the proper torque. Furnished with 2 carriage bolts and flange nuts.

Trivantage® is a registered trademark of Glen Raven, Inc.



No. 215020

AWNING HARDWARE – SLIP-FIT COUPLING

Trivantage® Slip-Fit fittings, made of sturdy, plated, shockproof malleable iron, or plated steel as shown, offer a time and labor saving way to install patio awnings. No threading necessary, as all fittings simply slip on or over pipe frame, and are then secured by means of square head set screws. Slip-Fit fittings permit rapid adjustment when pipe is not cut to exact length.

ITEM #	STYLE #	FINISH	FRONT BAR SIZE	MATERIAL	STANDARD PACKAGE
215020	14-6	Galvanized	1 in. pipe	Iron	25

Trivantage® is a registered trademark of Glen Raven, Inc.



No. 123389



No. 225135



No. 244540

AWNING HARDWARE – SLIP-FIT SQUARE ELBOW

Trivantage® Slip-Fit fittings, made of sturdy, plated, shockproof malleable iron, or plated steel as shown, offer a time and labor saving way to install patio awnings. No threading necessary, as all fittings simply slip on or over pipe frame, and are then secured by means of square head set screws. Slip-Fit fittings permit rapid adjustment when pipe is not cut to exact length.

Plated, malleable iron. Square design ensures a better fitting cover. Used to join front bars with end rafters. Ideal for use in joining right angles of any frame assembly. Furnished with set screws.

ITEM #	STYLE #	FRONT BAR SIZE	RAFTER	STANDARD PACKAGE
123386	285	1/2 in. pipe	1/2 in. pipe	25
123387	287	3/4 in. pipe	3/4 in. pipe	25
123389	289	1 in. pipe	1 in. pipe	25
225135*	15-7	1-1/4 in. pipe	1-1/4 in. pipe	25
244540	20-6	1 in. pipe	1 in. pipe	25

*225135 - Hot dip galvanized – smooth design, with socket head screw.

Trivantage® is a registered trademark of Glen Raven, Inc.



No. 124190

AWNING HARDWARE – SLIP-FIT EYE END

Trivantage® Slip-Fit fittings, made of sturdy, plated, shockproof malleable iron, or plated steel as shown, offer a time and labor saving way to install patio awnings. No threading necessary, as all fittings simply slip on or over pipe frame, and are then secured by means of square head set screws. Slip-Fit fittings permit rapid adjustment when pipe is not cut to exact length. A specially designed, plated, malleable iron eye end, properly proportioned for greatest rigidity. Small eye permits snug fit between eye end and rod and rafter holder. Barrel depth of 2 inch assures greater holding power between eye end and pipe. Furnished with set screw.

ITEM #	STYLE #	MAXIMUM BOLT STANDARD	SIZE	STANDARD PACKAGE
124188	286	1/4 in.	1/2 in. pipe	25
124190*	290	7/16 in.	3/4 in. pipe	25
124191*	291	7/16 in.	1 in. pipe	25
124192	292	1/2 in.	1-1/4 in. pipe	25

*124190 - Also available in aluminum.
 *124191 - Also available in aluminum.

Trivantage® is a registered trademark of Glen Raven, Inc.



No. 163704

AWNING HARDWARE – SLIP-FIT ADJUSTABLE POST SOCKET – FOR BRICK – MALLEABLE IRON

Trivantage® Slip-Fit fittings, made of sturdy, plated, shockproof malleable iron, or plated steel as shown, offer a time and labor saving way to install patio awnings. No threading necessary, as all fittings simply slip on or over pipe frame, and are then secured by means of square head set screws. Slip-Fit fittings permit rapid adjustment when pipe is not cut to exact length.

Furnished with two lag screw holes for attaching to brick. Plated, malleable iron, furnished with set screw. Also available in aluminum.

ITEM #	STYLE #	SIZE POST	STANDARD PACKAGE
163703	3	3/4 in. pipe	25
163704	4	1 in. pipe	25

Trivantage® is a registered trademark of Glen Raven, Inc.



No. 130581

AWNING HARDWARE – SLIP-FIT ADJUSTABLE FRONT BAR

Trivantage® Slip-Fit fittings, made of sturdy, plated, shockproof malleable iron, or plated steel as shown, offer a time and labor saving way to install patio awnings. No threading necessary, as all fittings simply slip on or over pipe frame, and are then secured by means of square head set screws. Slip-Fit fittings permit rapid adjustment when pipe is not cut to exact length.

A fitting made of plated steel clamps and zinc die-cast collar, with many applications where a sturdy reinforced assembly is required. Ideal for patio awning pipe frame assemblies, supporting pipe posts, pipe braces, and all types of special pipe frames.

The interlocking three-piece fitting provides a rigid, low cost assembly. Slip top section over pipe and adjust to desired position. Tighten set screw. Both hands are free to quickly bolt interlocking bottom section to top section for completed assembly.

ITEM #	STYLE #	FRONT BAR SIZE	REDUCING FOR PIPE SIZE	STANDARD PACKAGE
130580	280	3/4 in. pipe	3/4 in. pipe	25
130581	281	1 in. pipe	1 in. pipe	25
130582	282	1 in. pipe	3/4 in. pipe	25

Tolerance on sand casting: 1/32 inch to 4 inch dimension, 3/64 inch to 4 inch to 8 inch dimension. Tolerance on die casting: ± 0.005 inch.

Trivantage® is a registered trademark of Glen Raven, Inc.



No. 163702

AWNING HARDWARE – SLIP-FIT ADJUSTABLE POST SOCKET – FOR WOOD – MALLEABLE IRON

Trivantage® Slip-Fit fittings, made of sturdy, plated, shockproof malleable iron, or plated steel as shown, offer a time and labor saving way to install patio awnings. No threading necessary, as all fittings simply slip on or over pipe frame, and are then secured by means of square head set screws. Slip-Fit fittings permit rapid adjustment when pipe is not cut to exact length.

Furnished with four wood screw holes for attaching to wood. Plated, malleable iron, furnished with set screw.

ITEM #	STYLE #	SIZE POST	STANDARD PACKAGE
163701	1	3/4 in. pipe	25
163702	2	1 in. pipe	25

Trivantage® is a registered trademark of Glen Raven, Inc.



No. 174375



No. 174377



No. 274030

AWNING HARDWARE – SLIP-FIT TEE

Trivantage® Slip-Fit fittings, made of sturdy, plated, shockproof malleable iron, or plated steel as shown, offer a time and labor saving way to install patio awnings. No threading necessary, as all fittings simply slip on or over pipe frame, and are then secured by means of square head set screws. Slip-Fit fittings permit rapid adjustment when pipe is not cut to exact length.

Plated, malleable iron. Special cast lip on inside of slip tee prevents inserted pipe from interfering with pipe crossing in other direction. Can be used for: joining upright posts to front bars, joining rafters to front bars, joining special types of frames, such as carports, carnival booths, etc. Furnished with set screws.

ITEM #	STYLE #	EXTENSION	FRONT BAR SIZE	STANDARD PACKAGE
174375	275	1/2 in. pipe	1/2 in. pipe	25
174377	277	3/4 in. pipe	3/4 in. pipe	25
174379	279	1 in. pipe	1 in. pipe	25
225121	25-2	3/4 in. pipe	3/4 in. pipe	25
274030*	25-7	1-1/4 in. pipe	1-1/4 in. pipe	25

*274030 - Hot dip galvanized – does not have cast lip, with socket head screw.

Trivantage® is a registered trademark of Glen Raven, Inc.



No. 173504



No. 173604

SLIP TEE

Plated, malleable Iron. The run is not threaded and can be slipped over the front bar. The extension outlet is tapped.

ITEM #	STYLE #	EXTENSION BAR THREADED	FRONT (SLIP FIT)	STANDARD PACKAGE	TYPE
173504	4	3/4 in. pipe	3/4 in. pipe	25	Without set screws
173604	4	3/4 in. pipe	3/4 in. pipe	25	With set screws
173622	22	1/2 in. pipe	1/2 in. pipe	25	With set screws



No. 138615

AWNING HARDWARE – BRACKET HINGE

Plated, die-cast zinc. Furnished with machine screw and hex nut. Also available in aluminum.

ITEM #	STYLE #	PROJECTION	STANDARD PACKAGE
138615	O-B	1 in.	25



No. 138737

AWNING HARDWARE – CAMELBACK HINGE – ZINC DIE-CAST

Plated, zinc die-cast. Fastens the projection arms of awning frames to a building. Furnished with machine screws.

No. 11 is identical in design to the No. 2, but has a round head shoulder screw with “pilot” for holding No. 1 Sheet Brass Grommets.



No. 238020

ITEM #	STYLE #	PROJECTION	STANDARD PACKAGE
138737	11	11/16 in.	25
238020*	2	11/16 in.	25

*238020 - Also available in aluminum.



No. 263913



No. 263923

AWNING HARDWARE – ROUND HEAD MACHINE SCREW

ITEM #	DESCRIPTION	FOR	MATERIAL	SIZE	STANDARD PACKAGE
263913	Round Head Machine Screw	No. 11 and C.B. Hinge	Plated	12-24 x 7/8 in.	100
263923	Round Head Shoulder Screw	No. 2 C.B. Hinge, No 34. S.S. Hinge	Stainless Steel	12-24 x 3/4 in.	100

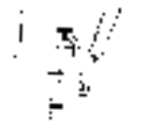

No. 139180

AWNING HARDWARE – EXTRA PROJECTION HINGE

Made of plated, malleable iron. Designed for box type awning or casement windows. Extra projection allows awning frame to fold flat against building. Pipe clamps on lower frame are easily moved to align frame with building. Also designed for ranch-type homes for use on ceiling of "overhang" when standard rod and rafter holder would not be suitable. Used with No. 30 Head Rod Clamp with fastening holes and shipped with Round Head Machine Screw.

ITEM #	STYLE #	PROJECTION	STANDARD PACKAGE
139180	15	1-1/2 in.	25



No. 139064

AWNING HARDWARE – HINGE – STAMPED STEEL

Plated. Furnished with machine screw.

ITEM #	STYLE #	GAUGE	STANDARD PACKAGE
139064	34	14	25



No. 124514

AWNING HARDWARE – JAW END – FOR STEEL BEAMS

Jaw ends only, less bolt.

ITEM #	STYLE #	JAW OPENING	MATERIAL	PROJECTION	STANDARD PACKAGE	THREADED FOR SIZE
124514	34-B	7/16 in.	Aluminum Extrusion	1-1/2 in.	25	3/8 - 16



No. 124504

AWNING HARDWARE – JAW END WITH LAG SCREW

Used to attach awning frame to a brick surface. Furnished with machine screw and square nut. Projection is from shoulder of jaw to center of bolt hole in jaw.

ITEM #	STYLE #	JAW OPENING	LAG SCREW SIZE	MATERIAL	PROJECTION	STANDARD PACKAGE	USE EXPANSION SHIELD
124504	4	7/16 in.	3/8 in. x 2-1/2 in.	Aluminum Extrusion	1-1/2 in.	25	3/8 in. x 2 in.



No. 267301

AWNING HARDWARE – HINGE SILENCER SPRING

Easily installed between the eye end of the awning frame and the hinge to absorb play and eliminate noise and rattle. Made of fine quality plated, tempered strip steel.

ITEM #	STANDARD PACKAGE
267301	25



No. 140104

AWNING HARDWARE – ROD AND RAFTER HOLDER NO. 4

Rod and rafter holders are designed for attaching heads and rafters of patio or stationary awnings, eliminating the need for separate clamps for head rod or hinges for the rafters. Made of plated, malleable iron. Furnished with machine bolt and wing nut to hold the head rod, machine screw and square nut, for fastening the rafter.

A combination fixture for application on brick, wood or concrete. It has two countersunk holes for wood screws. There is also a hole for a 5/16 inch or 3/8 inch lag screw. The No. 4 Rod and Rafter Holder is especially suitable for application and installation on narrow trim boards.

ITEM #	STYLE #	SIZE HEAD ROD	STANDARD PACKAGE
140104	4	1/2 in. diameter iron	25



No. 138002

AWNING HARDWARE – SPEAR HEAD

Supplied in standard plain finish or plated, ductile iron.

ITEM #	STYLE #	DESCRIPTION	SIZE	STANDARD PACKAGE	THREADED FOR SIZE
138002	2	Plain	9-1/2 in.	25	1/2 in. pipe
138102	2	Plated	9-1/2 in.	25	1/2 in. pipe



No. 138102

AWNING HARDWARE – SPEAR HEAD TEE

Plated, malleable iron design permits spear point outlet to be flush with front bar. All outlets tapped for pipe.

ITEM #	STYLE #	ARM OUTLET	FRONT BAR OUTLET	SPEAR OUTLET	STANDARD PACKAGE
174403	3	1/2 in.	1/2 in.	1/2 in.	25
174405	5	3/4 in.	3/4 in.	1/2 in.	25



No. 174403

GUDGEON – SQUARE HOLE

For worm gears. For round shaft of center support.

ITEM #	FOR
136002	1-1/2 in. ID pipe



No. 136002

WINDING BRACE

Made of rigid plated steel with steel socket for 5/8 inch iron pipe. Fitted with 4 inch hardwood grip handles.

ITEM #	STYLE #	BRACE SWEEP	SIZE
106708	8	14 in.	5/8 in.



No. 106708

WORM GEAR ATTACHMENTS – COMBINATION COUPLING AND HOOK

Specially designed plated, malleable iron hook to securely engage eye of winding shaft when operating awning with winding brace. Standard equipment on all Trivantage® gears. Slips over 3/4 in. steel shaft. Furnished with round head machine screw.

ITEM #	STYLE #	STANDARD PACKAGE
141001	1	25



No. 141001



No. 147002

WORM GEAR ATTACHMENTS – UNIVERSAL OR KNUCKLE JOINT

Used for connecting worm gear drive shaft or for splicing two drive shafts. Made of plated, malleable iron sockets with steel, square knuckles.

ITEM #	STYLE #	FOR	STANDARD PACKAGE
147002	2	3/4 in. x 3/4 in. iron	25



No. 126001

WORM GEAR ATTACHMENTS – WINDING SHAFT EYE

Reinforced, plated, malleable iron eye, easily attaches to winding shaft with M6 (metric) bolt.

ITEM #	STYLE #	FOR	STANDARD PACKAGE
126001	1	1/2 in. iron	25
126002	2	5/8 in. iron	25
126003	3	3/8 in. pipe	25



No. 158342

PULLEY – STAMPED STEEL – SWIVEL EYE

ABS Plastic Single Sheave. Full-bearing, with heavy wire, open end swivel eyes that function smoothly. Sheaves prevent rope from being cut or frayed. Plated.

ITEM #	STYLE #	ROPE DIAMETER	SHEAVE DIAMETER	STANDARD PACKAGE	STYLE SHEAVE
158340*	50	1/8 in.	1/2 in.	25	Single
158341*	100	3/16 in.	5/8 in.	25	Single
158342	300	1/4 in.	1 in.	25	Single

*158340 - Also available in aluminum.

*158341 - Also available in aluminum.



No. 256102

PULLEY – SWIVEL EYE

Made with high grade cast iron swivel eyes and bodies, steel rivets and steel sheaves. Nickel-plated and lacquered for extra rust protection.

ITEM #	STYLE #	ROPE DIAMETER	SHEAVE DIAMETER	STANDARD PACKAGE	STYLE SHEAVE
256101	5	3/8 in.	1-1/4 in.	25	Single
256102	6	3/8 in.	1-1/2 in.	25	Double
256103*	1	3/16 in.	3/4 in.	25	Single
256104*	2	3/16 in.	3/4 in.	25	Double
256105*	3	1/4 in.	1 in.	25	Single
256106	3/0	1/8 in.	1/2 in.	25	Single
256107	4/0	1/8 in.	1/2 in.	25	Double

*256103 - Also available in aluminum.

*256104 - Also available in aluminum.

*256105 - Also available in aluminum.



No. 256103

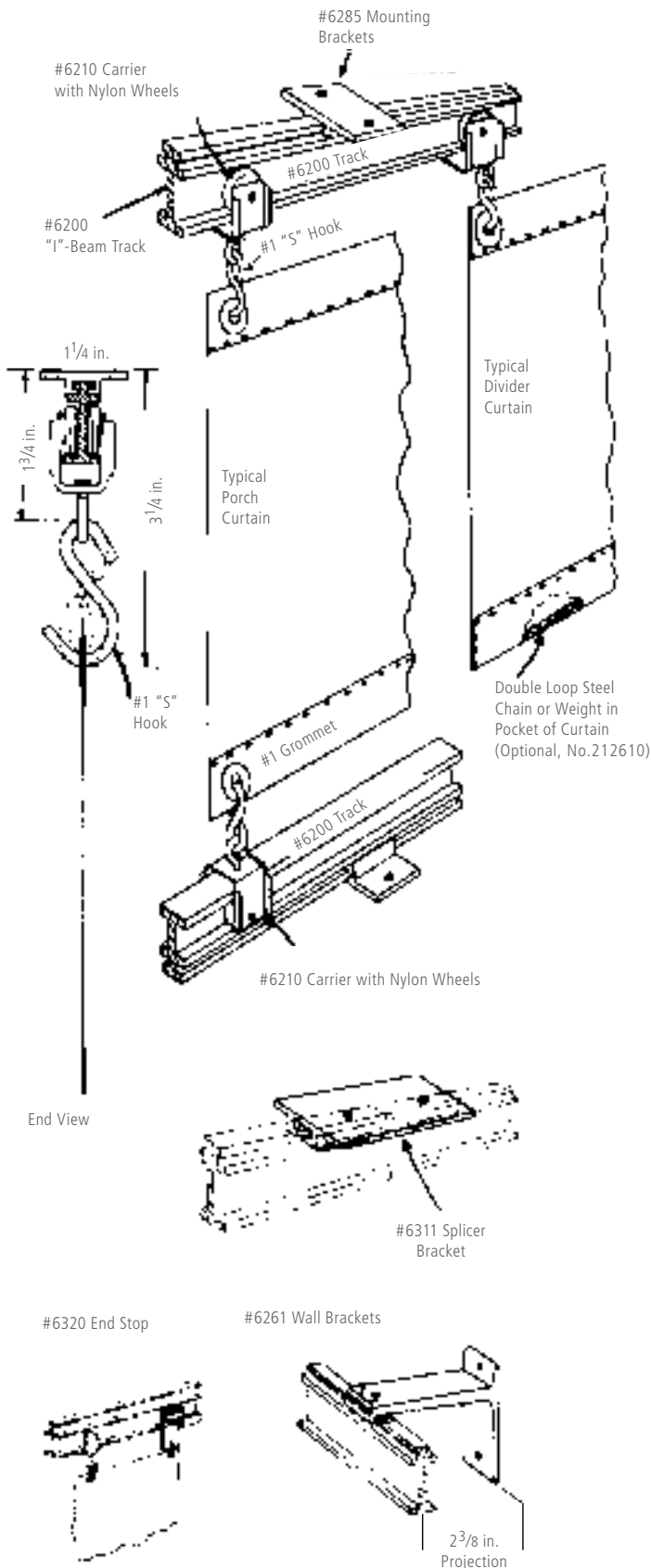

TRACK – LIGHTWEIGHT ALUMINUM TRACK NO. 6200

A versatile, lightweight, aluminum track of sturdy "1" Beam construction. Excellent for installation and operation of any width fabric curtain up to 12 foot high. The streamlined design of this extruded aluminum track provides a sturdy construction and attractive appearance. The track can be bent manually to form curves of any radius greater than 6 inches. Friction-free nylon wheel carriers, normally spaced 12 inches apart, have heavy metal eyes accommodating Trivantage® No. 1 "S" Hooks to secure grommet in curtain to the carrier. For installation, the Trivantage No. 6200 Track is supported by slip-on brackets that are easily mounted to ceiling or wall. Slip-on track splicers and end stops can be easily installed on the job.

Mounting bracket #6285 is for attachment directly to ceiling and should be spaced 2 feet 6 inches to 3 feet apart. Wall mounting bracket #6261 provides 2-3/8 inches of projection from wall and should be spaced 2 feet 6 inches apart.

The zinc-plated steel carrier #6210 with zinc-plated steel swivel eye is normally spaced 12 inches apart.

Splicer bracket #6311 slips over top of track and locks two sections together with set screws. End stop #6320 is a slip-on attachment for track ends.

Recommended for interior use only.

ITEM #	STYLE #	DESCRIPTION	STANDARD PACKAGE
206815	6285 Part 2-55	Ceiling Mounting Bracket	50
206821	6261 Part 2-55	Wall Mounting Bracket	40
211410	6210 Part 2-67	Carriers with Nylon Wheels	100
267141	6311 Part 2-55	Splicer Bracket	10
268320	6320 Part 2-55	End Stop	20
275621	6200	I-Beam Track 12 ft.	60 ft.

Trivantage® is a registered trademark of Glen Raven, Inc.





No. 578164

KEDER RAIL

Aluminum.

ITEM #	STYLE #	BEAD SIZE	LENGTH
578164	48.6025.31.05	17 mm	16.4 ft.
578165	48.6025.31.025	17 mm	8.2 ft.
578166	48.5524.31.05	18 mm	16.4 ft.
578167	48.5524.31.025	18 mm	8.2 ft.



No. 578160



No. 578161



No. 578162



No. 578163

CROCODILE HANGER®

Crocodile Hangers combine the strong sliding and movement features of Ball Hooks with the durability of Bar Sliders. The composition and design allows excellent durability for use in a range of environments.

ITEM #	STYLE #	DESCRIPTION	SIZE	STANDARD PACKAGE
578160	35.0927.41	Ball Hook	9 mm	100
578161	35.2727.41	Calott Slider	9 mm	100
578162	35.8027.41.21	Keder Track Roller with Screw Caps	9 mm	100
578163	25.8309.18	Stainless Steel Screws		100

Crocodile Hanger® is a registered trademark of American Keder, Inc.



KEDER – MARINE AND TENT

Keder is designed specifically for use in outdoor tensile structures where strength and resistance to the elements are critical. Made from a unique, heavy-duty polyester fabric welded to a solid PVC cord. It is easy to sew and won't tear out. It easily slides through Flex-A-Rail and various PVC and aluminum tracks.

ITEM #	STYLE #	DESCRIPTION	COLOR	PUT UP	SIZE
578103	12.0830.11	Double Tongue	White	110 yd.	8.5 mm
578104	13.0820.11	Welded Tongue	White	110 yd.	8.5 mm
578105	13.0820.19	Welded Tongue	Black	110 yd.	8.5 mm
578106	13.0720.11	Welded Tongue	White	110 yd.	7.5 mm
578107	11.0830.11	Single Tongue	White	110 yd.	8.5 mm
578111	13.0722.19	Welded Tongue	Black	110 yd.	7.5 mm
578125		Half Moon	White	109 yd.	
578126		Half Moon	Black	109 yd.	
578130			White	109 yd.	7.5 mm
578131			Black	109 yd.	7.5 mm
578133	C7420		White	109 yd.	8.5 mm x 20 mm x 2 mm
578134	C7420		Black	109 yd.	8.5 mm x 20 mm x 2 mm
578135			White	218 yd.	13 mm x 40 mm x 20 mm
578136			White with Blackout	218 yd.	13 mm x 40 mm x 20 mm
578137			Panama with Blackout	218 yd.	11 mm x 40 mm x 20 mm
578138			White with Grey Blackout	218 yd.	12 mm x 40 mm x 20 mm

TRACK – STEEL CURTAIN TRACK SYSTEM – 12 GAUGE – ROLLER TRACK

Create privacy and partitions with the Trivantage® line of curtain hardware. This 12 gauge galvanized steel system includes a range of products that suspend and anchor the curtain system, as well as a variety of trolleys that allow the curtains to roll.

ITEM #	STYLE #	DESCRIPTION	GAUGE	LENGTH	MATERIAL
206838	12RT-240	Track	12	20 ft.	Galvanized Steel

Trivantage® is a registered trademark of Glen Raven, Inc.

TRACK – STEEL CURTAIN TRACK SYSTEM – 12 GAUGE – INDUSTRIAL CURTAIN TROLLEY

Create privacy and partitions with the Trivantage® line of curtain hardware. This 12 gauge galvanized steel system includes a range of products that suspend and anchor the curtain system, as well as a variety of trolleys that allow the curtains to roll.

ITEM #	STYLE #	DESCRIPTION	GAUGE
206836	12SR2-1/2(1/4)	Two-Wheel Trolley with Steel Wheels	12
206882	12ST	Four-Wheel Trolley and Steel Wheels	12

Trivantage® is a registered trademark of Glen Raven, Inc.



No. 206837

TRACK – STEEL CURTAIN TRACK SYSTEM – 12 GAUGE – TRACK SPLICE

Create privacy and partitions with the Trivantage® line of curtain hardware. This 12 gauge galvanized steel system includes a range of products that suspend and anchor the curtain system, as well as a variety of trolleys that allow the curtains to roll.

ITEM #	STYLE #	DESCRIPTION	GAUGE
206837	12TSWMU	Splice Wall Mount Up 4 in.	12

Trivantage® is a registered trademark of Glen Raven, Inc.

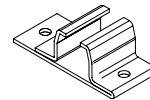

No. 206861

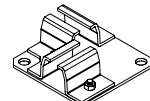

No. 206880

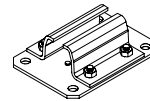

No. 206865

TRACK – STEEL CURTAIN TRACK SYSTEM – 16 GAUGE – CEILING SUPPORT BRACKETS

Create privacy and partitions with the Trivantage® line of curtain hardware. This 16 gauge galvanized steel system includes a range of products that suspend and anchor the curtain system, as well as a variety of trolleys that allow the curtains to roll.

Ceiling support brackets allow the track to be attached before or after the brackets are secured to the ceiling.

ITEM #	STYLE #	DESCRIPTION	GAUGE
206861	16TBC	Ceiling Bracket	16
206865	16TSC	Ceiling Bracket	16
206880	16TBAC	Right Angle Ceiling Bracket	16

Trivantage® is a registered trademark of Glen Raven, Inc.



No. 206854

TRACK – STEEL CURTAIN TRACK SYSTEM – 16 GAUGE – CURVED TRACK

The standard curved track has end connectors for securing to adjacent sections of the roller track. The standard curve has a two-foot 90-degree radius.

ITEM #	DESCRIPTION	GAUGE	STYLE #
206854	Curved Track – 90 degree 2 ft. radius	16	16CT

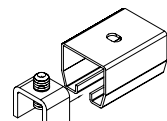

No. 206856

TRACK – STEEL CURTAIN TRACK SYSTEM – 16 GAUGE – END STOPS

End stops are used to prevent trolleys from rolling out of the ends of the track system.

ITEM #	STYLE #	GAUGE
206856	ES	16

TRACK – STEEL CURTAIN TRACK SYSTEM – 16 GAUGE – INDUSTRIAL CURTAIN TROLLEY

Create privacy and partitions with the Trivantage® line of curtain hardware. This 16 gauge galvanized steel system includes a range of products that suspend and anchor the curtain system, as well as a variety of trolleys that allow the curtains to roll.

Industrial curtain trolley is designed for larger, heavier curtains.

Two wheel trolleys with bumpers should be used in applications where the wheels of consecutive bumperless trolleys would rub together. In this case, the trolley frame extends beyond the outer portion of the wheel acting as a bumper. When the curtain weight exceeds 100 pounds or the curtain height is over 15 feet, steel ball bearing wheels should be used.

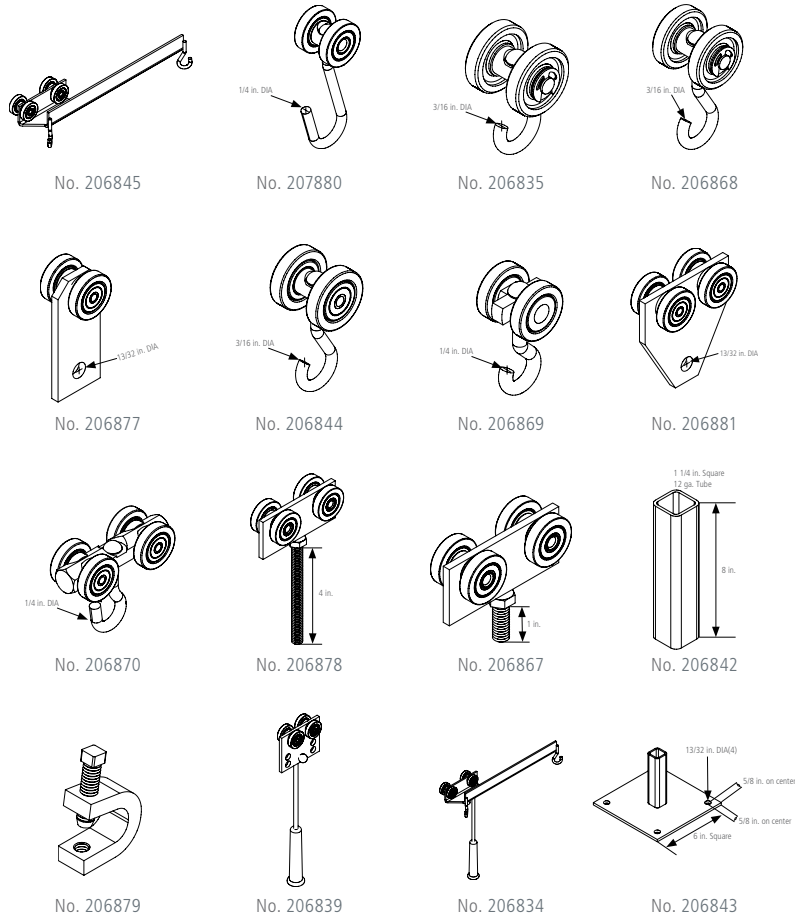

ITEM #	STYLE #	DESCRIPTION
206834	B3491-10	Overlapping Trolley with Steel Wheels and Pull Rope – 10 ft.
206835	16NR-1/2	Two-Wheel Trolley with Nylon Wheels
206839	B3427-10	Trolley with Pull Rope – 10 ft.
206842	A256-8	Floor Column Square – 8 ft.
206843	BS6	Base Plate
206844	16SR1	Two-Wheel Trolley with Steel Wheels
206845	16OT	Four-Wheel Trolley with Overlapping Wheels
206866	16NR1	Two-Wheel Trolley with Nylon Wheels
206867	16STS-4	Four-Wheel Trolley with Bumper and Steel Wheels – 1" Bolt
206868	16NR1B	Two-Wheel Trolley with Bumper and Nylon Wheels
206869	16SR1B	Two-Wheel Trolley with Bumper and Steel Wheels
206870	16ST1	Four-Wheel Trolley and Steel Wheels – 1" Hook
206877	16SR	Two-Wheel Trolley with Rectangular Plate and Steel Wheels
206878	16STS-4	Four-Wheel Trolley with Bumper and Steel Wheels – 4" Bolt
206879	A3120-2	Edge Clip with Nut/Set Screw
206881	16ST	Four-Wheel Trolley with Plate
207880	16SR2-1/2(1/4)	Two-Wheel Trolley with Steel Wheels

Trivantage® is a registered trademark of Glen Raven, Inc.

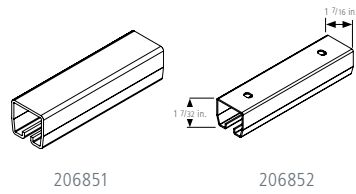

TRACK – STEEL CURTAIN TRACK SYSTEM – 16 GAUGE – ROLLER TRACK

The roller track is roll formed from 16 gauge hot dipped galvanized steel. The trolley wheels roll on the track floor between the outside track wall and the inside safety flange. The ends of the track are punched so that the track splices can lock two adjoining track ends together.

ITEM #	STYLE #	GAUGE	LENGTH	MATERIAL
206851	16RT-120	16	10 ft.	Galvanized Steel
206852	16RT-240	16	20 ft.	Galvanized Steel

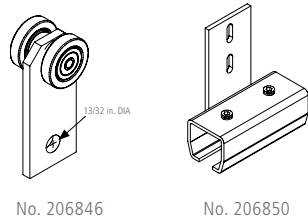

TRACK – STEEL CURTAIN TRACK SYSTEM – 16 GAUGE – COMPONENTS

ITEM #	STYLE #	DESCRIPTION
206846	16R-SS	Two-Wheel Trolley with Stainless Steel Wheels
206847	16TS-SS	Splice – 4"
206849	16NRISS	Two-Wheel Trolley with Bumper and Nylon Wheels
206850	16TSWUSS	Splice Wall Mount Up – 4 in.

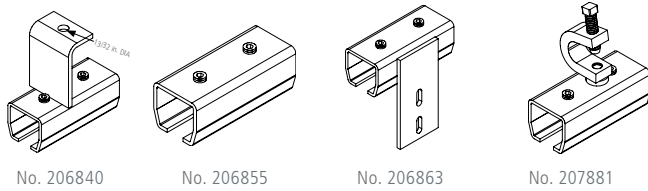

TRACK – STEEL CURTAIN TRACK SYSTEM – 16 GAUGE – TRACK SPLICE

The track splice is used to secure two straight sections of track together.

ITEM #	STYLE #	DESCRIPTION	GAUGE	MATERIAL
206840	16TSTR	Splice with Angle Bracket	16	Galvanized Steel
206855	16TS	Splice – 4 in.	16	Galvanized Steel
206863	16TSWMD	Splice Wall Mount Down – 4 in.	16	Galvanized Steel
206864	16TSWMU	Splice Wall Mount Up – 4 in.	16	Galvanized Steel
207881	16TSEC	Edge Clamp	16	Galvanized Steel

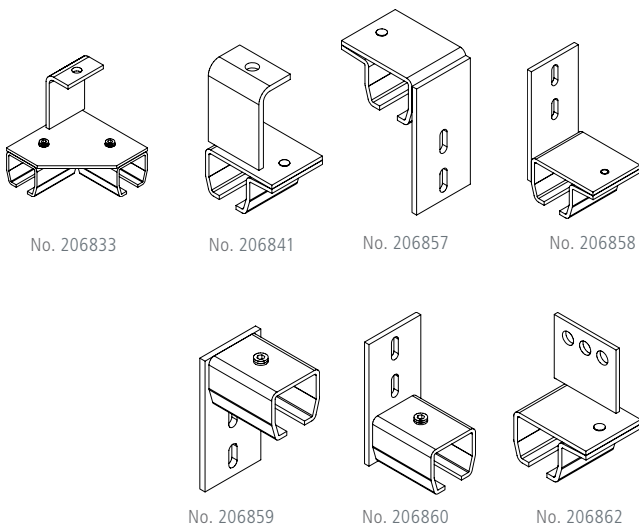

TRACK – STEEL CURTAIN TRACK SYSTEM – 16 GAUGE – WALL MOUNT AND END MOUNT BRACKETS

Wall mount and end mount brackets are used when the track system is running adjacent to a wall.

ITEM #	STYLE #	DESCRIPTION	GAUGE
206833	16TBATR	Right Angle Threaded Rod Bracket	16
206841	16TBTR	Threaded Rod Bracket	16
206848	A1422-1	Support Clamp	16
206857	16TBWMD	Wall Mount Down	16
206858	16TBWMU	Wall Mount Down	16
206859	16EMD	End Mount Down	16
206860	16EMU	End Mount Down	16
206862	16TBV	Vertical Bracket	16



No. 260981

PORCELAIN RINGS

Porcelain Rings are manufactured with a strong and smooth finish for longer rope life. Gray color. Use clips shown below for suspending rings.

ITEM #	STYLE #	APPROXIMATE INSIDE DIAMETER	APPROXIMATE OUTSIDE DIAMETER	COLOR	SIZE	STANDARD PACKAGE
260981	1	3/4 in.	1-5/8 in.	Gray	Small	25
260982	2	1 in.	2 in.	Gray	Medium	25



No. 117201

RING CLIPS

ITEM #	STYLE #	FINISH	STANDARD PACKAGE	TYPE
117201	2	Plated Steel	25	Standard
117203	1	Plated Steel	25	Heavy
117205	3	Stainless Steel	25	



No. 212610

CHAIN – DOUBLE LOOP STEEL

This galvanized steel chain is ideal for application in awning curtain pockets as a “weight” to prevent curtain from flapping in the wind. Also, practical for supporting “hanging canopies” and “stationary awnings”, or as a chain lift on slide rod awnings, etc. Flexible and strongly made, heavy and of rigid galvanized steel wire.

ITEM #	STYLE #	STANDARD PACKAGE
212610	1/0	100 ft.



No. 214201

CLEAT – AWNING

These rope cleats offer strong and durable design for outdoor use. For use on wood. Also available in aluminum.

ITEM #	STYLE #	LENGTH	MATERIAL	NUMBER OF HOLES	STANDARD PACKAGE	USED WITH
214201	1	4-1/2 in.	Die-cast zinc	2	25	No. 8 wood screw
214202	2	6 in.	Die-cast zinc	2	25	No. 10 wood screw
266676	2	6 in.	Die-cast zinc	2	100	No. 10 wood screw



No. 249614

CURTAIN LOOP – SHOWER/BATH

Nickel plated steel.

ITEM #	STYLE #	SIZE	STANDARD PACKAGE
249614	30570	1 in.	25



No. 294650

HOOK – ROLLER

For attaching a roller curtain to pipe, or tubing. Can be used for underneath an awning or canopy, or in a stand-alone application.

ITEM #	STYLE #	SIZE OPENING	STANDARD PACKAGE
294650	101	3/4 in. or 1 in. pipe	25



No. 223680

DISC AND PRONG

Brass discs and prongs with slightly larger dimensions. One set includes two discs and one prong.



No. 223687

ITEM #	DESCRIPTION	MATERIAL	STANDARD PACKAGE
223680	Prong	Brass	500
223687	Disc	Brass	1000

FLUORESCENT EGGCRATE LOUVERS

Eggcrate louvers have a perimeter which allows continuous appearance mounting by overlapping factory edges. UV resistant. **Sold by full case only.**

ITEM #	STYLE #	CELL SIZE	COLOR	MATERIAL	STANDARD PACKAGE
249700	10	1/2 in. x 1/2 in. x 1/2 in.	White	Acrylic	10
249705	14	1/2 in. x 1/2 in. x 3/8 in.	White	Acrylic	15
249710	20	1/2 in. x 1/2 in. x 1/2 in.	White	Styrene	10
249720	24	1/2 in. x 1/2 in. x 3/8 in.	White	Styrene	15

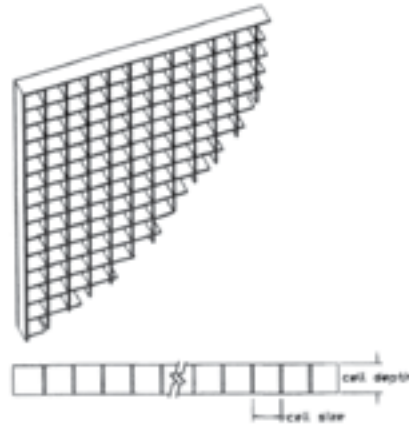

Eggcrate louvers have a perimeter which allows continuous appearance mounting by overlapping factory edges.



No. 107601

BRACKET – Z

Awning frames can easily be mounted with these brackets. Made from 3/16 inch hot rolled steel, they are supplied plated, or plain (for applications requiring painting). Two holes spaced equally for lagging into mortar are provided to secure bracket to wall. There is also a 3/16 inch hole to accommodate a Teks® screw for fastening the frame. Will accommodate a 3/8 inch lag screw.



No. 107610



No. 239954



No. 239955

ITEM #	STYLE #	FINISH	LENGTH	SQUARE TUBE SIZE	ROUND TUBE SIZE	STANDARD PACKAGE	TYPE
107601	#2	Plain	4-3/4 in.	1 in.	1.050 in.	25	Medium
107602	#2	Plated	4-3/4 in.	1 in.	1.050 in.	25	Medium
107606	#1	Plated	4-1/2 in.	3/4 in.	0.840 in.	25	Small
107609	#0	Plain	2-1/8 in.	1 in.	1.050 in.	25	Mini
107610	#0	Plated	2-1/8 in.	1 in.	1.050 in.	25	Mini
107615	#3	Plain	4-13/16 in.	1-1/4 in.	1.315 in.	25	Large
107616	#3	Plated	4-13/16 in.	1-1/4 in.	1.315 in.	25	Large
206810*		Plated	2-1/16 in.	1 in.	1.029 in.	25	
239954		Zinc Plated		1 in. small		25	
239955		Zinc Plated		1 in. large		25	

*206810 - Made from high tensile cold rolled steel, zinc plated, 1-1/2 inch wide.

Teks® is a registered trademark of Illinois Tool Works, Inc.



No. 107375

BRACKET – JOINING

Frame joining brackets allow covered frame sections to be easily joined together without obvious and unsightly joints. Adjoining modular frame sections of different or identical heights, depths, and shapes will appear as one continuous awning when installed.

ITEM #	SIZE	STANDARD PACKAGE
107375	2 in.	25
239956	2 in.	25



No. 107630

BRACKET – L

Made from 3/16 inch hot rolled steel. Two holes spaced equally for lagging into mortar are provided to secure bracket to wall. There is also a 3/16 inch hole to accommodate a Teks® screw for fastening the frame. Will accommodate a 3/8 inch lag screw.

ITEM #	STYLE #	FINISH	LENGTH	SQUARE TUBE SIZE	STANDARD PACKAGE	TYPE
107630	#10	Plated	1-9/32 in.	1 in. or 3/4 in.	25	Large

Teks® is a registered trademark of Illinois Tool Works, Inc.



HEAD ROD – ELECTRO-GALVANIZED

In the bending process of making awning frames, this awning iron will not break when bent to right angles. The zinc plating will not chip or flake off during bending. Drawn to full sizes, the iron threads easily and exactly for perfect fitting with pipe-threaded frame fixtures. Also used for lacing and tie down bars, and in conjunction with head rod molding.

ITEM #	DIAMETER	LENGTH	NUMBER OF PIECES PER BUNDLE	WEIGHT PER BUNDLE	WEIGHT PER FOOT
244516	3/8 in.	20 ft.	17	128 lbs.	0.38 lbs.
244518	1/2 in.	20 ft.	12	160 lbs.	0.67 lbs.
244520	5/8 in.	20 ft.	5	105 lbs.	1.04 lbs.

HEAD ROD – FIBERGLASS

ITEM #	COLOR	NUMBER OF PIECES PER BUNDLE	SIZE	STANDARD PACKAGE
244616	White	5	3/8 in. x 20 ft.	100 ft. bundle
244625	White	15	1/2 in. x 20 ft.	300 ft. bundle



No. 555 180° open molding

MOLDING – ALUMINUM AWNING

A fast and easy way to install covers. Mill finish, all-aluminum molding that remains in place all year. 6063-T6 aluminum. Cover slides into place easily. 1/4 inch rope is sewn into hem at top of cover. Then, the rope-filled hem slips into the channel of the molding. Allows for easy installation and removal. PE Tubing, Vinyl Welt, or 8.5 m Keder Welt can also be used.



No. 555 90° open molding

Product is also commonly known as “trailer” molding.

No. 555 Moldings are lighter in weight than No. 777, and are flexible enough to form and bend to varying shapes. Recessed mounting face conforms readily to uneven surfaces.



No. 555 curved molding



No. 777 molding

ITEM #	STYLE #	DEGREE OF CHANNEL	LENGTH	OVERALL HEIGHT	ROPE SIZE	STANDARD PACKAGE	THICKNESS	WEIGHT PER CARTON	WEIGHT PER FOOT
251001	555	90 degrees	20 ft.	1-1/8 in.	1/4 in. in hem	35/carton	3/64 in.	78 lbs.	0.112 lbs.
251007	555	180 degrees	8 ft.	1-1/8 in.	1/4 in. in hem	72 ft.	3/64 in.	9 lbs.	0.123 lbs.
251008	555	180 degrees	18 ft.	1-1/8 in.	1/4 in. in hem	216 ft.	3/64 in.	27 lbs.	0.123 lbs.
251009	555	90 degrees	8 ft.	1-1/8 in.	1/4 in. in hem	72 ft.	3/64 in.	9 lbs.	0.124 lbs.
251010	555 Curved	90 degrees	18 ft.	1-1/8 in.	1/4 in. in hem	216 ft.	3/64 in.	27 lbs.	0.124 lbs.
251011	555 Curved	90 degrees	8 ft.	1-1/8 in.	1/4 in. in hem	72 ft.	3/64 in.	10 lbs.	0.140 lbs.
251012	555	90 degrees	18 ft.	1-1/8 in.	1/4 in. in hem	216 ft.	3/64 in.	30 lbs.	0.140 lbs.
251017	777	45 degrees	8 ft.	1-1/4 in.	1/4 in. in hem	72 ft.	3/64 in.	12 lbs.	0.160 lbs.
251018	777	45 degrees	18 ft.	1-1/4 in.	1/4 in. in hem	216 ft.	3/64 in.	35 lbs.	0.160 lbs.
275812	555	90 degrees	20 ft.	1-1/8 in.	1/4 in. in hem	600 ft.	3/64 in.		
275813	555	180 degrees	20 ft.	1-1/8 in.	1/4 in. in hem	600 ft.	3/64 in.		

MOLDING – ALUMINUM AWNING – BRIGHT DIPPED

Bright dipped anodized aluminum.

ITEM #	STYLE #	DESCRIPTION	DEGREE OF CHANNEL	FINISH	LENGTH	STANDARD PACKAGE	WEIGHT PER FOOT
251050	A15	Molding	135 degrees	Bright Dipped Anodized	16 ft.	400 ft.	0.12 lbs.



No. 578002

WELTING – VINYL

Use in place of rope headers on awnings that attach to motor homes, travel trailers, campers and other recreational vehicles. Can be used in conjunction with aluminum awning molding or with the extruded channel already provided by many of the RV manufacturers.

ITEM #	STYLE #	COLOR	PUT UP	SIZE
578001	A02-002	White	300 ft.	31/32 in. with 5/16 in. bead
578002	A02-004	Black	300 ft.	31/32 in. with 5/16 in. bead
578098	6022	Black	100 ft.	31/32 in. with 5/16 in. bead



No. 265755

EMSEAL UST AWNING/SIGN SEALANT TAPE

Why spend time caulking behind awning frames and suffer the frustration of messy jobs, dripped caulk and caulking in bad weather, when all you have to do is apply Awning Foam Sealant to the frame before it's hoisted on the wall?

Available in dimensions to fit most building surfaces, this self-expanding polyester polyurethane foam is filled with water-based stabilized acrylics and will not dry out, shrink or deteriorate when compressed and properly installed. Just peel off the release liner and apply the adhesive side to the back of the awning. This is a continuous seal that is easy to install at ground level, thus providing a safer and more efficient installation atmosphere.

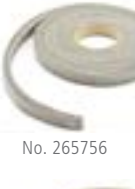
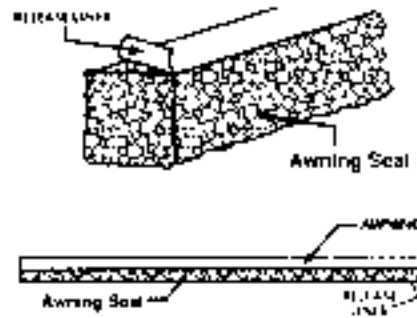

No. 265756



No. 265757

ITEM #	BUILDING SURFACE	SIZE	STANDARD PACKAGE
265755	Stucco, Block, Brick	5/32 in. x 5/8 in. x 26.24 ft.	1050 ft., 40 rolls/case
265756	Split Block	11/32 in. x 3/4 in. x 13.12 ft.	394 ft., 30 rolls/case
265757	Commercial Grade Corrugated Metal	5/16 in. x 3/4 in. x 13.12 ft.	420 ft., 32 rolls/case



No. 578054

XTREME SEAL® AWNING SEAL

Awning installations are a breeze with Xtreme Seal Awning Seal. Designed for the awning industry as a gasket material between the frame and the mounting surface, Xtreme Seal Awning Seal conforms to the contour of the mounting surface, eliminating the need for silicone and providing a clean finished product. Made of EPDM material, Xtreme Seal Awning Seal also features an adhesive back, saving time and making mounting easy.

ITEM #	STYLE #	COLOR	PUT UP
578054	POD-AW	Black	250 ft.

Xtreme Seal® is a registered trademark of Xtreme Seal LLC.



No. 515500

TUBING “PE” – LOW-DENSITY POLYETHYLENE

Polyethylene tubing for use in the head of awnings, and for marine and tonneau covers when using aluminum awning rail. Will not rot, absorb water, shrink, or unravel.

ITEM #	STYLE #	PUT UP	SIZE
515498	A02-007	1000 ft.	3/16 in. OD x 1/8 in. ID
515500	A02-005	1000 ft.	1/4 in. OD x 1/8 in. ID
578095	PEH8321000-6-SP	1000 ft.	1/4 in. OD x 1/8 in. ID

MOLDING – HEAD ROD MOLDING NO. 35/37



No. 117139



No. 124538



No. 124540

For installations at the head of stationary or patio awnings and for installation and adjustment of the rafters of patio awnings. Extruded from 6063-T6 aluminum - mill finish.

Nos. 35 and 37 Head Rod Moldings are designed for use with a 1/2 inch diameter conventional head rod to eliminate the awkward job of threading a rope-filled hem through a slot in the molding. The head rod is merely placed in position and finger clips are tightened to hold the head of the awning under the rainproof lip of the molding. The finger clips ride in a track in the molding and can be adjusted to move laterally right or left.

The advantage of this system is that rafters can be placed precisely, even if the surface is uneven or the mounting supports are not located where the rafters should be, because once the molding is mounted, the rafters can be slid to their proper location.

Recommended rafter spacing is 1 1/2 feet in from each side, and then 3 feet to 4 feet centers depending on projection (the longer the rafters, the less the spacing). Awning rafters are attached to special jaw ends that are mounted in a track in the lower side of the molding. The jaw ends can be moved laterally to adjust the rafter width. This is done by turning or tightening the jaw end, which is

fitted with a carriage bolt to ride in the same track as the finger clip.

The molding itself is designed so that a bead of caulking compound can be applied to the top length of the molding to prevent water from leaking behind the molding and down the wall.

The No. 35 Molding has the same basic design as the No. 37, but is 25% lighter in weight, with approximately 90% of the No. 37's strength. The No. 37 Finger Clip, No. 37W Jaw End and 1/2 inch Head Rod Clamp can be used with the No. 35 Molding without alteration.

ITEM #	STYLE #	DESCRIPTION	LENGTH	SIZE OUTSIDE DIAMETER	STANDARD PACKAGE	WEIGHT	WEIGHT PER FOOT
117139*	37	Finger clip assembly. Stainless steel carriage bolt, machine screw, hex nut and washers.			25		
124538*	37C	Jaw end with plated steel carriage bolt, machine screw, hex nut and washers.			25		
124540*	37W	Jaw end with stainless steel carriage bolt, machine screw, hex nut and washers.			25		
251032	37JB	Molding	20 ft.		8 pieces/160 ft.		0.640 lbs.
251033	35JB	Molding	20 ft.				
251034	37	Molding	8 ft.		72 ft.	61 lbs.	
251037	37	Molding	12 ft.		144 ft.	123 lbs.	
251039	37	Molding	20 ft.		160 ft.	137 lbs.	
251044	35	Molding	8 ft.		72 ft.	48 lbs.	
251049	35	Molding	20 ft.		160 ft.	107 lbs.	
251061	37WJB	Jaw End			25		
251100		Flat Bar	16 ft.	1 in. x 1/8 in.	320 ft.	41 lbs.	

*117139 - Finger clip assembly. Stainless steel carriage bolt, machine screw, hex nut and washers.

*124538 - Jaw end with plated steel carriage bolt, machine screw, hex nut and washers.

*124540 - Jaw end with stainless steel carriage bolt, machine screw, hex nut and washers.

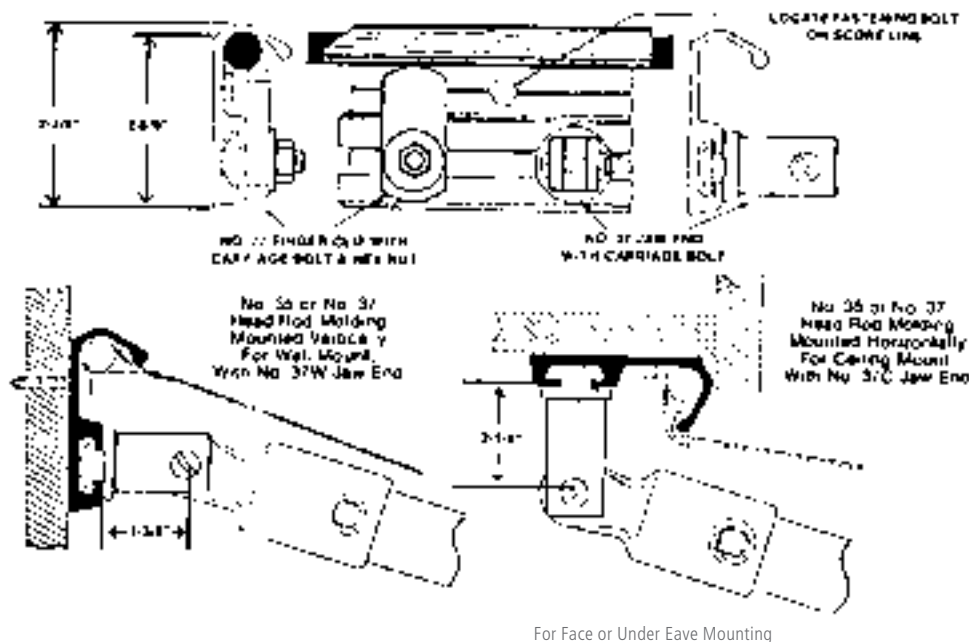

For Face or Under Eave Mounting

Trivantage® is a registered trademark of Glen Raven, Inc.



No. 238015

MOLDING – DIETZ HEAD ROD MOLDING

Dietz Headrail is a lightweight, continuous head and rafter holder extruded from 6063-T6 mill finish aluminum designed to provide easy, leakproof installations that combine strength, attractiveness, and economy. The need for a headerboard is eliminated.

The trailer molding-type opening eliminates the need for iron and provides an easy method for sliding the fabric through the molding. Conventional 1/4 inch rope or tubing is recommended for sewing in the head.

Cast aluminum alloy hinges are inserted with a simple quarter turn. It is not necessary to insert hinges from the end, which allows for easy installation of extra rafters.

Two grooves to facilitate drilling are strategically placed to offset thrust of frame and shrinkage of canvas, as well as allow ample clearance for 3/8 inch lag bolts or keystone anchors for brick installations.



ITEM #	STYLE #	LENGTH	STANDARD PACKAGE
237250	60	12 ft.	25
238015*	51		25

*238015 - Includes nut and 1/4 inch bolt.



TUBING – ALUMINUM SQUARE AND RECTANGULAR

Square and rectangular 6063-T6 extruded mill finish aluminum tubing for awning framing and sign boxes. Both forms are lightweight, and corrosion resistant, offering the best combination of strength, bending and welding characteristics.

ITEM #	LENGTH	SIZE	STANDARD PACKAGE	WEIGHT PER FOOT
275820*	20 ft.	1 in. x 1 in. x 0.100	400 pc master	0.442 lbs.
275821	20 ft.	1 in. x 1 in. x 0.125	400 pc master	0.491 lbs.
275823	20 ft.	1 in. x 2 in. x 0.125	180 pc master	0.826 lbs.
275824	20 ft.	1 in. x 2 in. x 0.060	180 pc master, 20 pc hand bundles, inside master	0.416 lbs.
275826*	24 ft.	1 in. x 1 in. x 0.125	400 pc master	0.491 lbs.
275831*	25 ft.	1 in. x 1 in. x 0.100	240 pc master	0.442 lbs.
275900	20 ft.	1 in. x 1 in. x 0.060	15	
275902	24 ft.	1 in. x 1 in. x 0.060	12	
275905	20 ft.	1 in. x 1 in. x 0.125	15	
275907	24 ft.	1 in. x 1 in. x 0.125	12	
275910	20 ft.	1 in. x 2 in. x 0.125	15	
275911	20 ft.	1 in. x 2 in. x 0.060	15	
275913	20 ft.	2 in. x 2 in. x 0.125	15	

*275820 - Paper layer.
 *275826 - Paper layer, cardboard surround.
 *275831 - Paper layer, cardboard surround.

Ceiling Panel Support Members

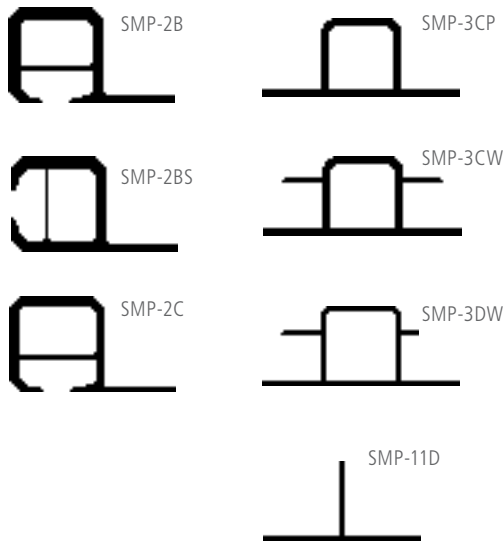

Channeled Stapling Members

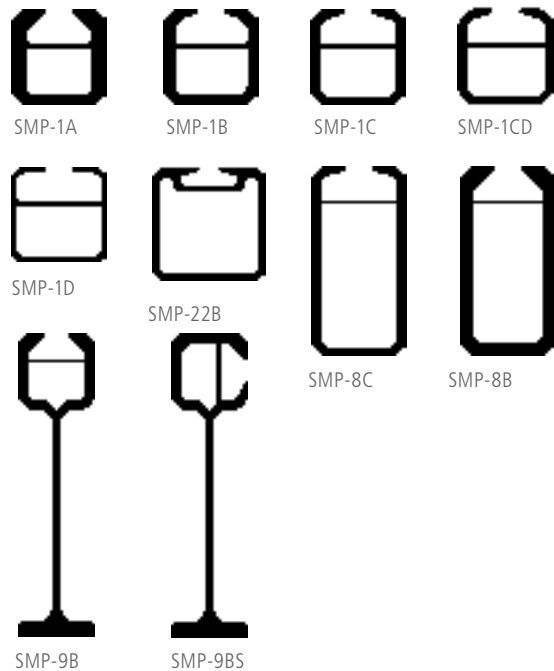

Support Members

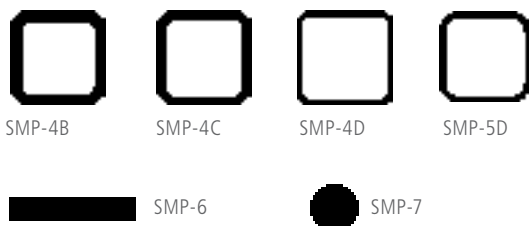

STEEL STITCH™ SYSTEMS EXTRUSIONS ALUMINUM

The Steel Stitch System offers flexibility in design and fabrication of interior and exterior awnings, canopies and back-lit signs. The aluminum alloy 6063-T5 mill finish frame system utilizes the “staple-in” method of attaching fabric, which is taken directly from the roll and stapled into a channel in the frame. A PVC finishing trim, in a choice of 30 colors plus Crystal Clear, is then driven into the channel to cover the staples. With the use of divider strips to join sections and the exclusive, patented FlashStrip®, which forms a watertight seal against building surfaces, the result is an attractive, seamless and wrinkle-free awning, canopy or sign.

ITEM #	STYLE #	DESCRIPTION	FEET PER BUNDLE	LENGTH	SIZE
250050	SMP-1A	Tube	250 ft.	25 ft.	1 in. x 1 in. x 3/16 in.
250052	SMP-1B	Tube	250 ft.	25 ft.	1 in. x 1 in. x 1/8 in.
250054	SMP-1C	Tube	250 ft.	25 ft.	1 in. x 1 in. x 1/10 in.
250055	SMP-1CD	Tube	250 ft.	25 ft.	1 in. x 1 in. x 0.090 in.
250056	SMP-1D	Tube	250 ft.	25 ft.	1 in. x 1 in. x 1/16 in.
250058	SMP-2B	Tube	250 ft.	25 ft.	1 in. x 1-3/4 in. x 1/8 in.
250060	SMP-2BS	Tube	200 ft.	20 ft.	1 in. x 1-3/4 in. x 1/8 in.
250062	SMP-2BS	Tube	250 ft.	25 ft.	1 in. x 1-3/4 in. x 1/8 in.
250064	SMP-2C	Tube	250 ft.	25 ft.	1 in. x 1-3/4 in. x 1/10 in.
250068	SMP-3CP	Tube	200 ft.	20 ft.	1 in. x 2-1/2 in. x 1/10 in.
250070	SMP-3CW	Tube	200 ft.	20 ft.	1 in. x 2-1/2 in. x 1/10 in.
250074	SMP-4B	Tube	200 ft.	20 ft.	1 in. x 1 in. x 1/8 in.
250076	SMP-4C	Tube	200 ft.	20 ft.	1 in. x 1 in. x 1/10 in.
250078	SMP-4C	Tube	250 ft.	25 ft.	1 in. x 1 in. x 1/10 in.
250080	SMP-4D	Tube	200 ft.	20 ft.	1 in. x 1 in. x 1/16 in.
250082	SMP-5D	Tube	200 ft.	20 ft.	7/8 in. x 7/8 in. x 1/16 in.
250084	SMP-6	Aluminum Bar	200 ft.	20 ft.	1 in. x 3/16 in.
250086	SMP-7	Aluminum Rod	200 ft.	20 ft.	1/2 in. OD
250088	SMP-8B	Tube	200 ft.	20 ft.	1 in. x 2 in. x 1/8 in.
250090	SMP-8B	Tube	250 ft.	25 ft.	1 in. x 2 in. x 1/8 in.
250091	SMP-8C	Tube	250 ft.	25 ft.	1 in. x 2 in. x 1/10 in.
250092	SMP-9B	Tube	250 ft.	25 ft.	1 in. x 4 in. x 1/8 in.
250094	SMP-9BS	Tube	250 ft.	25 ft.	1 in. x 4 in. x 1/8 in.
250096	SMP-10B	Tube	250 ft.	25 ft.	4 in. OD x 1/8 in.
250097	SMP-15B	Tube	150 ft.	25 ft.	1-1/2 in. x 1-1/2 in. x 1/8 in.
250098	SMP-11D	Tube	200 ft.	20 ft.	7/8 in. x 1-3/4 in. x 1/16 in.
250099	SMP-22B	Tube	150 ft.	25 ft.	2 in. x 2 in. x 1/8 in.
250255	SMP-503	Tube	120 (mill)	20 ft.	2 in. x 2 in. x 1/8 in.
275908	SMP-502	Tube	80 (mill)	20 ft.	1-1/2 in. x 1-1/2 in. x 1/8 in.

Steel Stitch™ is a trademark of Steel Stitch Corporation. FlashStrip® is a registered trademark of Steel Stitch Corporation.



No. 213238

CLAMP – LOCKING WELDER’S

Unique “U” shape throat allows odd sized materials to be clamped together. Compound action for powerful non-slip locking grip. Convenient, quick, one-hand release lever.

ITEM #	STYLE #	DESCRIPTION	STANDARD PACKAGE
213238	586-9R	9 in. Locking Clamp Vise (Plated)	1

GATORSTITCH™

GatorStitch is a superior strength frame tubing product that incorporates an aluminum stapling web embedded within a 1 inch galvanized steel tube. Like the Steel Stitch™ system, fabric is stapled into a channel of the GatorStitch frame, resulting in an attractive, seamless and wrinkle-free, drum-tight awning or sign.

Use this Steel Stitch product like you would the aluminum framing system with the same tools, pvc trim, and covering techniques. Save money on your material cost due to the superior strength and lower cost of steel. GatorStitch is fabricator-friendly and works with any awning or flex-face sign fabric, including woven acrylics, laminated and coated vinyls, polyester blends, and open mesh weaves. Fabric wear is reduced because of the systems fabric-to-frame attachment points. GatorStitch is 1 inch square and made of 18 gauge high strength steel having a maximum yield strength of 50,000 psi and tensile strength of 55,000 psi. Weld to existing steel for retrofits or large structures. Meet project specifications that call for steel framing.

Bending GatorStitch

GatorStitch can be bent with the stapling channel facing out using a standard 3-wheel roller bender. The minimum possible radius varies by machine and can be reduced by bending gradually in multiple passes.

GatorStitch Corrosion Protection

A triple layer of zinc, conversion coating, and clear epoxy protects the inside and outside surfaces of the steel and act as a barrier between the steel and the aluminum insert.

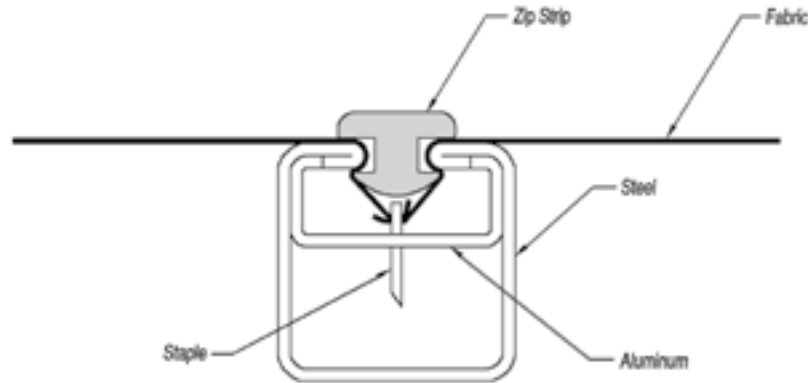

ITEM #	APPROXIMATE WEIGHT PER PIECE	FEET PER BUNDLE	GAUGE	LBS PER FOOT	LENGTH	PIECES PER BUNDLE	SHAPE	SIZE OUTSIDE DIAMETER	WEIGHT PER BUNDLE
276150	13.8 lbs.	1200 ft.	18	0.6891 lbs.	20 ft.	60	Square	1 in.	833 lbs.

Gatorstitch™ is a trademark of Allied Tube & Conduit Corporation. Steel Stitch™ is a trademark of Steel Stitch Corporation.



No. 250046

STEEL STITCH™ STAPLE-IN TUBE FOR MARINE APPLICATIONS

Exclusively from Trivantage®, this Round Staple-in Tube is bright dip anodized for a polished look and maximum corrosion resistance, making it ideal for biminis, boat tops and other marine applications.

This 1-1/4 inch round tube's staple-in channel opening is the same width as all Steel Stitch extrusions, ensuring compatibility with both Steel Stitch Fabric and PVC ZipStrip®.

The tube has similar strength characteristics to 1-1/4 inch diameter, 16 gauge stainless steel and 1-1/4 inch diameter, 1/8 inch sidewall aluminum, so you can create your boat tops without worry. The tube can be bent by three wheel roller benders to a radius of approximately 12 inches. (Requires dies wide enough for the 1-1/4 inch diameter).

Each tube is 25 feet in length, and available in 250 foot bundles. Shipping weight is 18.25 pounds per piece.

ITEM #	STYLE #	FEET PER BUNDLE
250046	9125RBA	250 ft.

Steel Stitch™ is a trademark of Steel Stitch Corporation. ZipStrip® is a registered trademark of Steel Stitch Corporation. Trivantage® is a registered trademark of Glen Raven, Inc.



No. 249917

STEEL STITCH™ ZIPSTRIP®

Designed to cover the staples once the fabric has been stapled into position. Product is driven into the open channel using an air hammer.

ITEM #	COLOR	COLOR NUMBER	PUT UP
249901	White	01	400 ft. rolls
249902	Black	02	400 ft. rolls
249903	Gray	03	400 ft. rolls
249904	Cream	04	400 ft. rolls
249905	Beige	05	400 ft. rolls
249906	Brown	06	400 ft. rolls
249910	Plum	10	400 ft. rolls
249911	Burgundy	11	400 ft. rolls
249912	Rouge Red	12	400 ft. rolls
249913	Dark Blue	13	400 ft. rolls
249914	Medium Blue	14	400 ft. rolls
249916	Aquamarine	16	400 ft. rolls
249917	Grass Green	17	400 ft. rolls
249918	Dark Green	18	400 ft. rolls
249919	Yellow	19	400 ft. rolls
249920	Pumpkin	20	400 ft. rolls
249921	Terra Cotta	21	400 ft. rolls
249922	Linen	22	400 ft. rolls
249923	Deep Red	23	400 ft. rolls
249924	Bright Red	24	400 ft. rolls
249925	Royal Blue	25	400 ft. rolls
249926	Bright Blue	26	400 ft. rolls
249927	Teal	27	400 ft. rolls
249928	Turquoise	28	400 ft. rolls
249929	Golden Yellow	29	400 ft. rolls
249930	Bright Orange	30	400 ft. rolls
249931	Crystal Clear	31	400 ft. rolls
249933	Violet	32	400 ft. rolls
249934	Bordeaux	33	400 ft. rolls
249935	Magenta	34	400 ft. rolls
250301	White	01	150 ft. rolls

ITEM #	COLOR	COLOR NUMBER	PUT UP
250302	Black	02	150 ft. rolls
250303	Grey	03	150 ft. rolls
250304	Cream	04	150 ft. rolls
250305	Beige	05	150 ft. rolls
250306	Brown	06	150 ft. rolls
250310	Plum	10	150 ft. rolls
250311	Burgundy	11	150 ft. rolls
250312	Rouge Red	12	150 ft. rolls
250313	Dark Blue	13	150 ft. rolls
250318	Dark Green	18	150 ft. rolls
250319	Yellow	19	150 ft. rolls
250321	Terra Cotta	21	150 ft. rolls
250322	Linen	22	150 ft. rolls
250323	Deep Red	23	150 ft. rolls
250324	Bright Red	24	150 ft. rolls
250325	Royal Blue	25	150 ft. rolls
250329	Golden Yellow	29	150 ft. rolls
250331	Crystal Clear	31	150 ft. rolls
250332	Violet	32	150 ft. rolls
250333	Bordeaux	33	150 ft. rolls

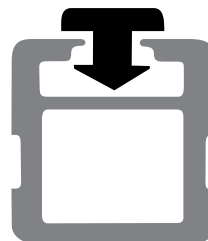

Steel Stitch™ is a trademark of Steel Stitch Corporation. ZipStrip® is a registered trademark of Steel Stitch Corporation.



No. 249879



No. 249873

STEEL STITCH™ ZIPSTRIP® – SUNBRELLA® FABRIC

This fabric covered PVC staple channel trim creates a traditional finish on woven canvas awnings and canopies. Fabric covered ZipStrip is made with Sunbrella acrylic fabrics that completely conceal the PVC material. A durable lockstitch double seam holds the fabric securely in place for years of attractive performance. Custom colors and fabrics are available.

ITEM #	COLOR	COLOR NUMBER
249871	Pacific Blue	6001
249873	Jockey Red	6003
249875	Persian Green	6043
249876	Navy	6026
249877	Black Cherry	6040
249878	Black	6008
249879	Beige	6020
249880	True Brown	6021
249881	Terra Cotta	6022
249882	Toast	6028
249890	Cadet Grey	6030
249891	Burgundy	6031
249893	Linen	6033
249894	Forest Green	6037
249895	Seagrass Green	6045
249896	Captain Navy	6046
249897	Oyster	6042
249899	Alpine	6055

Steel Stitch™ is a trademark of Steel Stitch Corporation. ZipStrip® is a registered trademark of Steel Stitch Corporation. Sunbrella® is a registered trademark of Glen Raven, Inc.



No. 249836

STEEL STITCH™ ZIPSTRIP® – FIRESIST® FABRIC

This fabric covered PVC staple channel trim creates a traditional finish on woven canvas awnings and canopies. Fabric covered ZipStrip is made with Firesist fabrics that completely conceal the PVC material. A durable lockstitch double seam holds the fabric securely in place for years of attractive performance. Custom colors and fabrics are available.

ITEM #	COLOR	COLOR NUMBER
249831	Regatta	82000
249832	Forest Green Tweed	82002
249833	Forest Green	82003
249834	Regatta Tweed	82005
249835	Sand	82006
249836	Black	82008
249837	Admiral Navy	82010
249838	Toast Beige	82012
249839	Sunburst Yellow	82013
249844	Burgundy	82016
249845	Crimson	82017

ZipStrip® is a registered trademark of Steel Stitch Corp. Firesist® is a registered trademark of Glen Raven, Inc.



No. 249811

STEEL STITCH™ ZIPSTRIP® – SUNBRELLA® FABRIC WITH TENARA® THREAD

This fabric covered PVC staple channel trim creates a traditional finish on woven canvas awnings and canopies. Fabric covered ZipStrip is made with Sunbrella acrylic fabrics that completely conceal the PVC material. A durable lockstitch double seam of Tenara thread holds the fabric securely in place for years of attractive performance. Custom colors and fabrics are available.

ITEM #	COLOR	COLOR NUMBER
249808	Charcoal Gray	4644
249809	Taupe	4648
249810	Pacific Blue	4601
249811	Jockey Red	4603
249813	Black	4608
249814	Terra Cotta	4622
249815	Toast	4628
249816	Burgundy	4631
249817	Linen	4633
249818	Forest Green	4637
249819	Captain Navy	4646
249820	Navy	4626
249821	Cadet Grey	4630
249822	Oyster	4642
249823	Seagrass Green	4645
249824	Brown	4621
249825	Beige	4620
249827	Medium Blue	4652
249829	Heather Beige	4672

ZipStrip® is a registered trademark of Steel Stitch Corp. Sunbrella® is a registered trademark of Glen Raven, Inc. Tenara® is a registered trademark of W.L. Gore & Associates, Inc.



No. 249855

STEEL STITCH™ ZIPSTRIP® – FIRESIST® FABRIC WITH TENARA® THREAD

This fabric covered PVC staple channel trim creates a traditional finish on woven canvas awnings and canopies. Fabric covered ZipStrip is made with Firesist fabrics that completely conceal the PVC material. A durable lockstitch double seam of Tenara thread holds the fabric securely in place for years of attractive performance. Custom colors and fabrics are available.

ITEM #	COLOR	COLOR NUMBER
249851	Regatta	82000
249852	Forest Green Tweed	82002
249853	Forest Green	82003
249854	Regatta Tweed	82005
249855	Sand	82006
249856	Black	82008
249857	Admiral Navy	82010
249858	Toast Beige	82012
249859	Sunburst Yellow	82013
249864	Burgundy	82016
249865	Crimson	82017

ZipStrip® is a registered trademark of Steel Stitch Corp. Firesist® is a registered trademark of Glen Raven, Inc. Tenara® is a registered trademark of W.L. Gore & Associates, Inc.



STEEL STITCH™ DIVIDERSTRIP®

Enables joining of awning and canopy modules on the job site.



No. 249981

ITEM #	COLOR	COLOR NUMBER	PUT UP
249951	White	01	200 ft. rolls
249952	Black	02	200 ft. rolls
249954	Cream	04	200 ft. rolls
249961	Burgundy	11	200 ft. rolls
249962	Rogue Red	12	200 ft. rolls
249964	Medium Blue	14	200 ft. rolls
249966	Aquamarine	16	200 ft. rolls
249968	Dark Green	18	200 ft. rolls
249981	Crystal Clear	31	200 ft. rolls

Steel Stitch™ is a trademark of Steel Stitch Corporation. DividerStrip® is a registered trademark of Steel Stitch Corporation.



STEEL STITCH™ FLASHSTRIP®

Driven into the back bar to create a secure seal against virtually any building surface. Eliminate the need for labor-intensive caulking by applying a single bead of the sealant to the product prior to installation. Available in Crystal Clear only.



No. 249950

ITEM #	COLOR	COLOR NUMBER	PUT UP
249950	Crystal Clear	31	125 ft. rolls

Steel Stitch™ is a trademark of Steel Stitch Corporation. FlashStrip® is a registered trademark of Steel Stitch Corporation.



No. 228022



No. 228033



No. 250153



No. 250216



No. 250162



No. 250198

STEEL STITCH™ ACCESSORIES

ITEM #	STYLE #	DESCRIPTION	PUT UP	SIZE	STANDARD PACKAGE
228022	9210MD	Steel Stitch Galvanized Steel Staples		3/8 in.	
228025	1812CG	Narrow Crown Galvanized Steel Staples		3/8 in.	
228026	1812CSS	Narrow Crown Stainless Steel Staples		3/8 in.	
228030	AH155	Danair Pneumatic Hammer			
228031	T155	Danair Hammer Replacement Tip, Blue			
228033	158	Danair Hammer Replacement Valve			
228035	AS0K151	Danair Hammer O-Ring Kit			
250153		Steel Stitch Grinding Disk			25
250157		Steel Stitch Galvanized Divergent Point Staples		3/8 in.	1 box
250158		Steel Stitch Galvanized Divergent Point Staples		1/2 in.	1 box
250162	92/25-553	Bea/Behrens Stapler with Safety			1 ea.
250198	F21T92-25AST	Fasco Stapler with Safety			1 ea.
250202		Steel Stitch Stainless Steel Staples			1 box
250205		Steel Stitch Galvanized Chisel Point Staples	5000/box	3/8 in.	1 box
250213	92/25-553	Bea/Behrens Stapler			1 ea.
250216	LU-9225AC	Apach Stapler with Case			1 ea.
250222		Steel Stitch Galvanized Chisel Point Staples	8400/box	1/2 in.	
267989	189	Oblong Clinch Staples			

STEEL STITCH™ GUIDES – AWNING MANUFACTURERS GUIDE

Extensive manual which covers every aspect of manufacturing the Steel Stitch awning system. Designed to be utilized by awning shops as a training manual for new employees and as a comprehensive shop reference. Presents a detailed analysis of awning and canopy design to structural consideration, then dissects each phase of the manufacturing process, including cutting, welding, fabric application and PVC trims. Also covers entire installation process, including transportation, hanging and connections.

ITEM #	DESCRIPTION
999645	Awning Manufacturer's Guide with CD-ROM
999646	Awning Manufacturer's Guide on CD-ROM

Steel Stitch™ is a trademark of Steel Stitch Corporation.

STEEL STITCH™ GUIDES – AWNING SPECIFIERS GUIDE

Provides qualified architects working primarily with commercial and multi-family housing design with complete and expanded detail needed to specify Steel Stitch™ fabric covered awnings. Contains general information and construction details, awning and canopy classifications, connection detail and complete written specifications for awnings, frames, finishes and fabrics. Includes a section on fabric selection containing samples of fabrics available from Trivantage®, for both internally-illuminated and non-illuminated applications. CAD drawings and text files are included on the CD-ROM.

ITEM #	DESCRIPTION
999647	Awning Specifiers Guide on CD-ROM

Steel Stitch™ is a trademark of Steel Stitch Corporation. Trivantage® is a registered trademark of Glen Raven, Inc.

GATORSHIELD® – GALVANIZED FINISH STEEL TUBING

GATORSHIELD® TUBING – GALVANIZED FINISH STEEL

Pipe Schedule 40

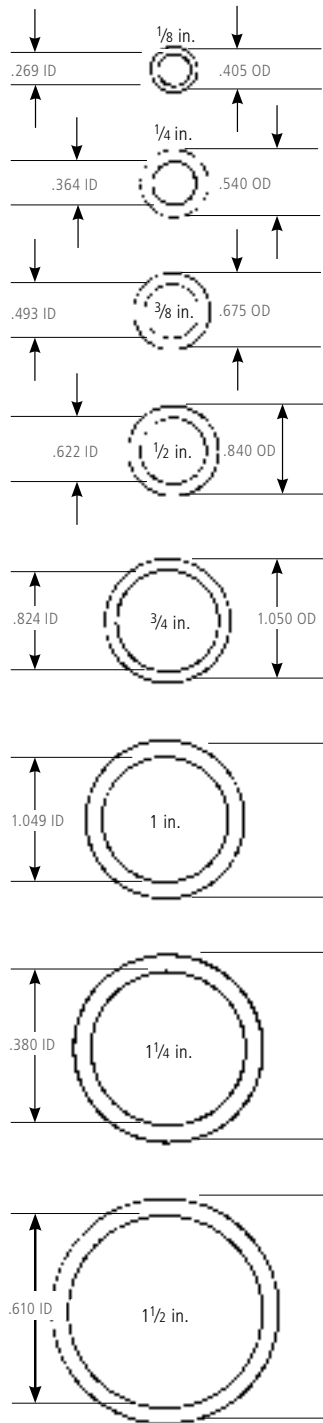

Gatorshield Wall Size

14 GA = .083 18 GA = .049
 15 GA = .072 20 GA = .035
 16 GA = .065

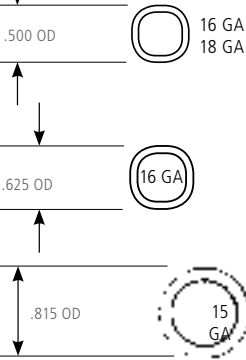

Mechanical Tubing
 (Numerous wall sizes available)

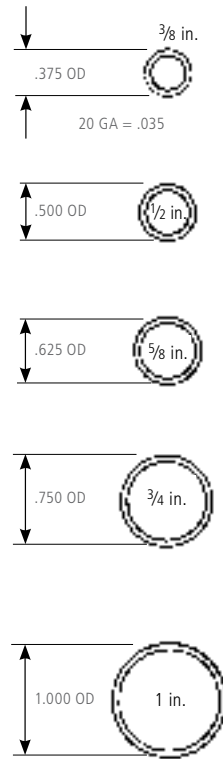

Awning Iron

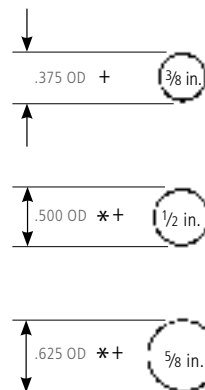

ID = Inside Diameter
 OD = Outside Diameter
 * = Available in Aluminum Headrod
 + = Available in Fiberglass Headrod

Gatorshield® is a registered trademark of Allied Tube & Conduit Corporation.

GATORSHIELD® – GALVANIZED FINISH STEEL TUBING

Gatorshield steel tubing offers triple layer corrosion protection on the exterior surface consisting of zinc, a conversion coating and a clear organic topcoat. The interior is fully covered with a corrosion-resistant zinc coating. Independent tests have proven our steel tubing offers dramatically higher corrosion resistance than other products being marketed for awning framework.

ITEM #	APPROXIMATE WEIGHT PER PIECE	FEET PER BUNDLE	GAUGE	LBS PER FOOT	LENGTH	PIECES PER BUNDLE	SHAPE	SIZE OUTSIDE DIAMETER	WEIGHT PER BUNDLE
276052	4.800 lbs.	1820 ft.	18	0.24 lbs.	20 ft.	91	Round	0.500	437 lbs.
276054	7.800 lbs.	1820 ft.	16	0.39 lbs.	20 ft.	91	Round	0.625	710 lbs.
276056	11.400 lbs.	1820 ft.	15	0.57 lbs.	20 ft.	91	Round	0.815	1037 lbs.
276057	27.328 lbs.	925 ft.	14	1.09 lbs.	25 ft.	37	Round	1.315	1011 lbs.
276058	16.800 lbs.	1220 ft.	14	0.84 lbs.	20 ft.	61	Round	1.029	1025 lbs.
276062	21.800 lbs.	740 ft.	14	1.09 lbs.	20 ft.	37	Round	1.315	807 lbs.
276064	13.200 lbs.	740 ft.	18	0.66 lbs.	20 ft.	37	Round	1.315	488 lbs.
276065	9.960 lbs.	2540 ft.	18	0.498 lbs.	20 ft.	127	Round	1.000	1265 lbs.
276066	28.000 lbs.	740 ft.	14	1.4 lbs.	20 ft.	37	Round	1.660	1036 lbs.
276080	13.200 lbs.	1600 ft.	16	0.66 lbs.	20 ft.	80	Square	13/16 in.	1673 lbs.
276083*	45.200 lbs.	888 ft.	13	1.833 lbs.	20 ft.	37	Round	1-1/2 in.	1013 lbs.
276084	16.600 lbs.	1200 ft.	16	0.83 lbs.	20 ft.	60	Square	1 in.	1241 lbs.
276085	20.680 lbs.	1500 ft.	16	0.83 lbs.	25 ft.	60	Square	1 in.	769 lbs.
276086	12.600 lbs.	1200 ft.	18	0.63 lbs.	20 ft.	60	Square	1 in.	561 lbs.
276087	48.806 lbs.	888 ft.	14	2.0336 lbs.	24 ft.	37	Round	2-3/8 in.	1806 lbs.
276088	9.200 lbs.	1200 ft.	20	0.46 lbs.	20 ft.	60	Square	1 in.	914 lbs.
276090	25.400 lbs.	720 ft.	16	1.27 lbs.	20 ft.	36	Square	1-1/2 in.	914 lbs.
276094	34.400 lbs.	500 ft.	16	1.72 lbs.	20 ft.	25	Square	2 in.	860 lbs.
276095	37.786 lbs.	500 ft.	15	1.89 lbs.	20 ft.	25	Square	2 in.	945 lbs.
276096	25.400 lbs.	640 ft.	16	1.27 lbs.	20 ft.	32	Rectangle	1 in. x 2 in.	813 lbs.
276099*	23.230 lbs.	768 ft.	18	0.968 lbs.	24 ft.	32	Rectangle	1 in. x 2 in.	744 lbs.
276100*	30.470 lbs.	768 ft.	16	1.27 lbs.	24 ft.	32	Rectangle	1 in. x 2 in.	974 lbs.
276104	54.600 lbs.	240 ft.	14	2.73 lbs.	20 ft.	25	Rectangle	2 in. x 3 in.	1365 lbs.
276108	75.100 lbs.	240 ft.	13	3.76 lbs.	20 ft.	25	Square	3 in.	1878 lbs.
276112	100.980 lbs.	320 ft.	13	5.05 lbs.	20 ft.	16	Square	4 in.	1616 lbs.

*276083 - Repacked bundle.

*276099 - Repacked bundle.

*276100 - Repacked bundle.

Gatorshield® is a registered trademark of Allied Tube & Conduit Corporation.

GATORSHIELD® – TUBING PLUG

ITEM #	DESCRIPTION	PUT UP	SIZE
255419	Square	200/package	13/16 in.
255420	Square	100/package	1 in.

Gatorshield® is a registered trademark of Allied Tube & Conduit Corporation.

TUBING – STEEL

Economical structured steel tubing for awning frames, galvanized inside and out equally. The weld seam on the outside diameter is re-metalized.

ITEM #	FEET PER BUNDLE	GAUGE	LENGTH	OUTSIDE DIAMETER	SHAPE	WEIGHT PER BUNDLE	WEIGHT PER FOOT
276411	1220 ft.	18	20 ft.	1.050	Round	639 lbs.	0.5239 lbs.
276412	1600 ft.	16	20 ft.	1.163	Round	1220 lbs.	0.7622 lbs.
276426	1600 ft.	18	20 ft.	0.750	Square	744 lbs.	0.4950 lbs.
276429	1200 ft.	18	20 ft.	1.000	Square	755 lbs.	0.6290 lbs.

GATORSHIELD® – TOUCH UP PAINT



No. 254160

ITEM #	PUT UP	STANDARD PACKAGE
254160	12 cans/case	12 oz. aerosol can

Gatorshield® is a registered trademark of Allied Tube & Conduit Corporation.



GROMMET – ALUMINUM WITH PLAIN WASHER



No. 233111

ITEM #	STYLE #	HOLE SIZE AFTER SETTING	STANDARD PACKAGE
233111	0	1/4 in.	25 gross
233112	1	9/32 in.	25 gross
233113	2	3/8 in.	25 gross
233114	3	7/16 in.	25 gross
233115	4	1/2 in.	25 gross



GROMMET – BRASS EYELET AND WASHER



No. 233209

ITEM #	STYLE #	DESCRIPTION	HOLE SIZE AFTER SETTING	STANDARD PACKAGE
225405	A-500	Eyelet	0.312 in.	1000
233209	2	Grommet with A1219 Washer		25 gross



GROMMET – BRASS ROLLED RIM WITH SPUR WASHER



No. 233311

These grommets and washers assure maximum strength and resistance to “pulling out.” Spur Type setting dies are required for inserting spur grommets.

ITEM #	STYLE #	HOLE SIZE AFTER SETTING	STANDARD PACKAGE
233310	0	9/32 in.	1 gross
233311	1	13/32 in.	1 gross
233312	2	7/16 in.	1 gross
233313	3	15/32 in.	1 gross
233314	4	9/16 in.	1 gross
233315	5	5/8 in.	1 gross
233316	6	3/4 in.	1 gross
233317	7	29/32 in.	1 gross
233318	8	1-3/32 in.	1 gross
233320	0	9/32 in.	25 gross
233321	1	13/32 in.	25 gross
233322	2	7/16 in.	25 gross
233323	3	15/32 in.	25 gross
233324	4	9/16 in.	25 gross
233325	5	5/8 in.	25 gross
233326	6	3/4 in.	25 gross
233327	7	29/32 in.	25 gross
235113	3	15/32 in.	Drum



GROMMET – BRASS ROLLED RIM WITH SELF-PIERCING WASHER – NICKEL PLATED



No. 233025

These grommets and washers assure maximum strength and resistance to “pulling out.” Spur Type setting dies are required for inserting spur grommets.









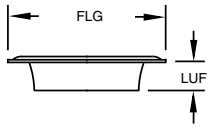

ITEM #	STYLE #	HOLE SIZE AFTER SETTING	STANDARD PACKAGE
233024	1	9/32 in.	500
233025	2	3/8 in.	500

GROMMET – BRASS ROLLED RIM WITH SPUR WASHER – BLACK

These grommets and washers assure maximum strength and resistance to “pulling out.” Spur Type setting dies are required for inserting spur grommets.

ITEM #	STYLE #	HOLE SIZE AFTER SETTING	STANDARD PACKAGE
233460	0	9/32 in.	1 gross
233461	1	13/32 in.	1 gross
233462	2	7/16 in.	1 gross
233463	3	15/32 in.	1 gross
233464	4	9/16 in.	1 gross
233465	5	5/8 in.	1 gross
233466	6	3/4 in.	1 gross
233467	7	29/32 in.	1 gross
233468	8	1-3/32 in.	1 gross
233470	0	9/32 in.	25 gross
233471	1	13/32 in.	25 gross
233472	2	7/16 in.	25 gross
233473	3	15/32 in.	25 gross
233474	4	9/16 in.	25 gross



<p>No. 1 Hole Size $\frac{9}{32}$ in.</p>  <p>FLG .687 LUF .185 MT .012</p>	<p>No. 00 Hole Size $\frac{3}{16}$ in.</p>  <p>FLG .425 LUF .135 MT .009</p>	<p>No. 0 Hole Size $\frac{1}{4}$ in.</p>  <p>FLG .545 LUF .175 MT .012</p>
<p>No. 2J Hole Size $\frac{3}{8}$ in.</p>  <p>FLG .840 LUF .260 MT .016</p>	<p>No. 1J Hole Size $\frac{9}{32}$ in.</p>  <p>FLG .680 LUF .263 MT .0126</p>	<p>No. 2 Hole Size $\frac{3}{8}$ in.</p>  <p>FLG .815 LUF .215 MT .013</p>
<p>No. 5 Hole Size $\frac{5}{8}$ in.</p>  <p>FLG 1.220 LUF .330 MT .016</p>	<p>No. 3 Hole Size $\frac{7}{16}$ in.</p>  <p>FLG .970 LUF .295 MT .014</p>	<p>No. 4 Hole Size $\frac{1}{2}$ in.</p>  <p>FLG 1.050 LUF .374 MT .016</p>
<p>No. 6 Hole Size $\frac{13}{16}$ in.</p>  <p>FLG 1.750 LUF .232 MT .020</p>		

Note: All dimensions are in inches. Photos approximate actual size. Hole size is approximate measurement after setting. Drum quantities vary with size.

GROMMET – BRASS WITH PLAIN WASHER

Made of heavy-gauge brass, assuring maximum strength and resistance against “pulling out.” Can be used interchangeably with plain or teeth washers. Meets Government Specifications, MIL-G-16491F, MS-20230, NASM-16491 and NASM-20230.

ITEM #	STYLE #	HOLE SIZE AFTER SETTING	STANDARD PACKAGE
233210	00	3/16 in.	1 gross
233211	0	1/4 in.	1 gross
233212	1	9/32 in.	1 gross
233213	1J	9/32 in.	1 gross
233214	2	3/8 in.	1 gross
233215	2J	3/8 in.	1 gross
233216	3	7/16 in.	1 gross
233217	4	1/2 in.	1 gross
233218	5	5/8 in.	1 gross
233219	6	13/16 in.	1 gross
233220	00	3/16 in.	25 gross
233221	0	1/4 in.	25 gross
233222	1	9/32 in.	25 gross
233223	1J	9/32 in.	25 gross
233224	2	3/8 in.	25 gross
233225	2J	3/8 in.	25 gross
233226	3	7/16 in.	25 gross
233227	4	1/2 in.	25 gross
233228	5	5/8 in.	25 gross
233229	6	13/16 in.	25 gross

GROMMET – BRASS WITH PLAIN WASHER – BLACK



No. 233374

Made of heavy-gauge brass, assuring maximum strength and resistance against “pulling out.” Can be used interchangeably with plain or teeth washers. Meets Government Specifications, MIL-G-16491F, MS-20230, NASM-16491 and NASM-20230.

ITEM #	STYLE #	HOLE SIZE AFTER SETTING	STANDARD PACKAGE
233360	00	3/16 in.	1 gross
233361	0	1/4 in.	1 gross
233362	1	9/32 in.	1 gross
233364	2	3/8 in.	1 gross
233366	3	7/16 in.	1 gross
233367	4	1/2 in.	1 gross
233370	00	3/16 in.	25 gross
233371	0	1/4 in.	25 gross
233372	1	9/32 in.	25 gross
233374	2	3/8 in.	25 gross
233376	3	7/16 in.	25 gross
233377	4	1/2 in.	25 gross
233378	5	5/8 in.	25 gross
233379	6	13/16 in.	25 gross

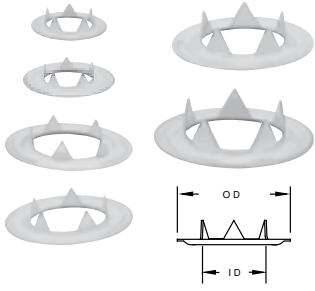

GROMMET – BRASS WITH TOOTH WASHER

ITEM #	STYLE #	HOLE SIZE AFTER SETTING	STANDARD PACKAGE
233230	0	1/4 in.	1 gross
233231	1	9/32 in.	1 gross
233233	2	3/8 in.	1 gross
233235	3	7/16 in.	1 gross
233236	4	1/2 in.	1 gross
233237	5	5/8 in.	1 gross
233240	0	1/4 in.	25 gross
233241	1	9/32 in.	25 gross
233243	2	3/8 in.	25 gross
233245	3	7/16 in.	25 gross
233246	4	1/2 in.	25 gross
233247	5	5/8 in.	25 gross



GROMMET – BRASS WITH TOOTH WASHER – BLACK

ITEM #	STYLE #	HOLE SIZE AFTER SETTING	STANDARD PACKAGE
233380	0	1/4 in.	1 gross
233390	0	1/4 in.	25 gross
233391	1	9/32 in.	25 gross
233393	2	3/8 in.	25 gross
233395	3	7/16 in.	25 gross



GROMMET – NICKEL-PLATED BRASS WITH PLAIN WASHER

ITEM #	STYLE #	HOLE SIZE AFTER SETTING	STANDARD PACKAGE
233520	00	3/16 in.	1 gross
233521	0	1/4 in.	1 gross
233522	1	9/32 in.	1 gross
233524	2	3/8 in.	1 gross
233526	3	7/16 in.	1 gross
233527	4	1/2 in.	1 gross
233528	5	5/8 in.	1 gross
233529	6	13/16 in.	1 gross
233530	00	3/16 in.	25 gross
233531	0	1/4 in.	25 gross
233532	1	9/32 in.	25 gross
233534	2	3/8 in.	25 gross
233536	3	7/16 in.	25 gross
233537	4	1/2 in.	25 gross
233538	5	5/8 in.	25 gross



GROMMET – NICKEL-PLATED WITH TOOTH WASHER

ITEM #	STYLE #	HOLE SIZE AFTER SETTING	STANDARD PACKAGE
233540	0	1/4 in.	1 gross
233541	1	9/32 in.	1 gross
233542	2	3/8 in.	1 gross
233543	3	7/16 in.	1 gross
233546	4	1/2 in.	1 gross
233547	5	5/8 in.	1 gross
233552	1	9/32 in.	1 gross
233553	2	3/8 in.	1 gross



GROMMET – NICKEL-PLATED ROLLED RIM BRASS WITH SPUR WASHER

ITEM #	STYLE #	HOLE SIZE AFTER SETTING	STANDARD PACKAGE
233620	0	9/32 in.	1 gross
233621	1	13/32 in.	1 gross
233622	2	7/16 in.	1 gross
233623	3	15/32 in.	1 gross
233624	4	9/16 in.	1 gross
233625	5	5/8 in.	1 gross
233626	6	3/4 in.	1 gross
233627	7	29/32 in.	1 gross
233628	8	1-3/32 in.	1 gross
233630	0	9/32 in.	25 gross
233631	1	13/32 in.	25 gross
233632	2	7/16 in.	25 gross
233633	3	15/32 in.	25 gross
233634	4	9/16 in.	25 gross



GROMMET – SELF-PIERCING WITH PLAIN WASHERS – BRASS SHARPENED

Will pierce most fabrics without pre-punching a hole, while setting the grommet and washer in the same action.

ITEM #	STYLE #	HOLE SIZE AFTER SETTING	STANDARD PACKAGE
233973	1	5/16 in.	100
233975	3	7/16 in.	100



GROMMET – SELF-PIERCING WITH PLAIN WASHERS – NICKEL PLATED SHARPENED



Will pierce most fabrics without pre-punching a hole, while setting the grommet and washer in the same action.

No. 233566

ITEM #	STYLE #	HOLE SIZE AFTER SETTING	STANDARD PACKAGE
233566	#2	3/8 in.	500
233567	#3	7/16 in.	100



GROMMET – SELF-PIERCING WITH WASHERS – NICKEL PLATED BRASS



Will pierce most fabrics without pre-punching a hole, while setting the grommet and washer in the same action.

No. 233019

ITEM #	STYLE #	HOLE SIZE AFTER SETTING	STANDARD PACKAGE
233017	3	7/16 in.	500
233019	2	3/8 in.	500



GROMMET – SELF-PIERCING WITH WASHERS – BRASS



Will pierce most fabrics without pre-punching a hole, while setting the grommet and washer in the same action.

No. 233022

ITEM #	STYLE #	HOLE SIZE AFTER SETTING	STANDARD PACKAGE
233020	0	1/4 in.	500
233021	1	5/16 in.	500
233022	2	3/8 in.	500
233023	3	7/16 in.	500
233032	2	3/8 in.	500

GROMMET – SPECIAL BRASS AND WASHERS

ITEM #	STYLE #	DESCRIPTION	FINISH	STANDARD PACKAGE
233071	1	Sharpened Edge Grommet with Plain Washer	Nickel Plated	500
233179	2	Grommet with A3630 Washer	Brass	Drum
233183	1	Grommet with A1340 Neck Washer	Black	25 gross
233184	1	Grommet with A1340 Neck Washer	Nickel	25 gross
233185	2	Grommet with Spur Washer	Paraffin Coated Brass	25 gross
233186	2	Grommet with A3630 Washer	Brass	25 gross
233188	1	Grommet with A1340 Neck Washer	Brass	25 gross
233519	0	Grommet with A-1197 Washer	Nickel Plated	25 gross
233589	2	Grommet with A-3630 Washer	Nickel Plated	25 gross

GROMMET – STAINLESS STEEL SELF-PIERCING ROLLED RIM WITH PLAIN WASHER

ITEM #	STYLE #	HOLE SIZE AFTER SETTING	STANDARD PACKAGE
235413	#1	5/16 in.	500
235414	#2	3/8 in.	500



GROMMET – STAINLESS STEEL SELF-PIERCING ROLLED RIM WITH SPUR WASHER



No. 233050

ITEM #	STYLE #	HOLE SIZE AFTER SETTING	STANDARD PACKAGE
233050	#0	1/4 in.	100
233051	#1	9/32 in.	100
233052	#2	3/8 in.	100
233053	#3	7/16 in.	100
233054	#4	1/2 in.	100
233055	#5	5/8 in.	100



E-Z LACE SUPREME®

E-Z Lace Supreme eliminates the need to insert grommets. A 1 inch reinforced side hole size makes lacing that much easier and quicker, while the 3 inch center spacing of the holes greatly increases manufacturing design flexibility. E-Z Lace Supreme also has a specialized and durable finish that resists mildew and ultraviolet rays, significantly increasing long-term strength and durability.

ITEM #	STYLE #	COLOR	PUT UP	WIDTH
502107	6601	Pacific Blue	50 yd.	2-1/8 in.
502108	6608	Black	50 yd.	2-1/8 in.
502109	6630	Cadet Gray	50 yd.	2-1/8 in.
502110	6631	Burgundy	50 yd.	2-1/8 in.
502111	6637	Forest Green	50 yd.	2-1/8 in.
502112	6604	Natural	50 yd.	2-1/8 in.

E-Z Lace Supreme® is a trademark of Offray Specialty Narrow Fabrics.



No. 207665



No. 207672

BUCKLES – “PUSH-BUTTON”

ITEM #	STYLE #	FINISH	STANDARD PACKAGE	WEBBING SIZE
207665	3105	Cadmium plated	500	1 in.
207667	6105	Nickel plated	100	3/4 in.
207668	6105	Cadmium plated	100	1 in.
207671	6105	Black enamel	100	1 in.
207672	6105	Stainless steel	100	1 in.
207673	6105	Stainless steel	100	1-1/2 in.
207674	6105	Nickel plated	100	1-1/2 in.
207677	6105	Nickel plated	100	1 in.
207724	6105	Nickel plated	100	1 in.



No. 207718

BUCKLES – CAM

Made of zinc die cast with zinc finish.

ITEM #	STYLE #	STANDARD PACKAGE	WEBBING SIZE
207718	09887R	400	1 in.
207725	09887R	400	1 in.



No. 207652

BUCKLES – FOR NYLON OR POLYESTER WEBBING

A 1 inch non-slip buckle developed to provide a positive hold on very smooth nylon or polyester webbing when webbing is threaded through the buckle.



No. 207680

ITEM #	STYLE #	FINISH	MATERIAL	STANDARD PACKAGE	WEBBING SIZE
207652	1020	Nickel plated		100	1 in.
207654		Nickel plated	Stamped steel	200	1 in.
207680	4042	Nickel plated		100	1 in.



No. 207558

BUCKLES – SINGLE BAR

For 1 inch webbing. Sheet brass, black finish. Meets Mil-B-543 Type 1, Style 2, Class 1.

ITEM #	STYLE #	STANDARD PACKAGE	WEBBING SIZE
207558	146	100	1 in.



No. 207508



No. 207516

BUCKLES – TONGUELESS

Dependable and sturdy buckles with a firm locking toothed slide. Made of the finest grade zinc-plated stamped steel. When ordering, specify Style # and size.



No. 207512



No. 207650

ITEM #	STYLE #	FINISH	STANDARD PACKAGE	TYPE	WEBBING SIZE
207508	635	Zinc plated	200	Type 1	1 in.
207512	2690	Cadmium plated	50	Type 1, 2, 3	1-1/2 in.
207516	5270	Cadmium plated	50	Type 1, 2, 3	2 in.
207517	5270	Nickel plated	100	Type 1, 2, 3	2 in.
207650	01055	Cadmium plated	100	Type 1, 2, 3	1 in.



No. 260441

CLIP AND DEE – NICKEL PLATED

ITEM #	STYLE #	INSIDE DIMENSION WIDTH	SIZE	SIZE HOLE	STANDARD PACKAGE
260441	1954	3/4 in.	1-3/8 in.	0.201 in.	1000



No. 213820

CLIP AND DEE – STAINLESS

ITEM #	STYLE #	INSIDE DIMENSION WIDTH	SIZE	SIZE HOLE	STANDARD PACKAGE
213820	1954	3/4 in.	1-3/8 in.	0.201 in.	1000



No. 249216

FOOTMAN LOOP

Made of zinc-plated steel. Used to secure web straps on car top carriers, boat covers, camping trailers and other specialty products. Undrilled Footman Loops for welding can also be supplied.

ITEM #	STYLE #	DIAMETER HOLE	SIZE	STANDARD PACKAGE	WEBBING SIZE
249203	518	7/32 in.	2-5/8 in.	1000	1 in.
249208	518	7/32 in.	2-5/8 in.	100	1 in.
249214	524	7/32 in.	3-1/8 in.	100	1-1/2 in.
249216	218	1/4 in.	3-5/8 in.	100	2 in.
249218	138	1/4 in.	2-3/4 in.	100	1-1/4 in.



No. 295565

WEBBING LOOP

Made of nickel-plated steel.

ITEM #	STYLE #	SIZE	STANDARD PACKAGE	TYPE
295560	4950	1 in. x 7/16 in.	100	Unwelded
295565	69900	2 in. x 7/16 in.	100	Unwelded



No. 275703

TRIANGLE RING

ITEM #	FINISH	MATERIAL	SIZE	STANDARD PACKAGE
275703	Nickel Plated	Steel	1-1/2 in. x 1-1/2 in. x 1-1/2 in.	100



No. 260507

DEE RING – NON-WELDED – ZINC PLATED

Made of steel wire, with a zinc plating. Non-welded.

ITEM #	STYLE #	INSIDE DIMENSION HEIGHT	INSIDE DIMENSION WIDTH	STANDARD PACKAGE	WIRE DIAMETER
260507	563	5/8 in.	3/4 in.	500	0.135 in.
260508	563	7/8 in.	1 in.	200	0.135 in.
260512	563	1-3/16 in.	1-1/2 in.	200	0.148 in.



No. 260527

DEE RING – WELDED – ZINC PLATED

Made of heavy steel wire, with a zinc plating. Welded.

ITEM #	STYLE #	INSIDE DIMENSION HEIGHT	INSIDE DIMENSION WIDTH	STANDARD PACKAGE	WIRE DIAMETER
260527	3250	3/4 in.	7/8 in.	100	0.207 in.
260528	3250	7/8 in.	1 in.	100	0.207 in.
260529	3250	1 in.	1-1/8 in.	100	0.207 in.
260530	3250	1-1/8 in.	1-1/4 in.	100	0.243 in.
260532	3250	1-5/16 in.	1-1/2 in.	50	0.253 in.
260534	3250	1-1/2 in.	1-3/4 in.	50	0.262 in.
260536	3250	1-5/8 in.	2 in.	50	0.262 in.



No. 260500

RING – DEE NICKEL PLATED

ITEM #	STYLE #	DESCRIPTION	FINISH	INSIDE DIMENSION HEIGHT	INSIDE DIMENSION WIDTH	MATERIAL	STANDARD PACKAGE	WIRE DIAMETER
260500	3250	Welded	Nickel Plated	1-3/5 in.	2 in.	Steel	500	0.260 in.
260502	563	Non-Welded	Nickel Plated	7/8 in.	1 in.	Steel	200	0.135 in.
260503	563	Non-Welded	Nickel Plated	5/8 in.	3/4 in.	Steel	500	0.135 in.
260511	45204	Non-Welded	Nickel Plated	8/9 in.	1 in.	Zinc Die-Cast	1000	0.154 in.



No. 260502



No. 260511



No. 267320

SPRING – TRAMPOLINE

ITEM #	LENGTH	STANDARD PACKAGE
267320	8 in.	100



No. 295531

WEBBING – 3 BAR SLIDE

Made of stamped steel, nickel plated. Used for garments, parkas, outerwear, equestrian equipment, horse blankets.



No. 295537

ITEM #	STYLE #	SIZE	STANDARD PACKAGE
295531	02300	1 in.	500
295532	02300	1-1/2 in.	500
295534	02300	2 in.	500
295537	03300	2 in.	200



No. 274908

WEBBING – TIP FOR TYPES I AND II WEBBING

Flat type. Nickel plated steel.

ITEM #	STYLE #	SIZE	STANDARD PACKAGE
274908	1	1 in.	1000



No. 275012

WEBBING – TIP FOR TYPES I, II AND III WEBBING

Ball type. Brass with black finish. Meets Government Specifications MIL-C-496.

ITEM #	STYLE #	SIZE	STANDARD PACKAGE
275008	149	1 in.	1000
275012	149	1-1/2 in.	200



No. 207697

ACW SIDE RELEASE BUCKLES



No. 207701

ITEM #	STYLE #	DESCRIPTION	COLOR	MATERIAL	WEBBING SIZE
207562	91151	Side Release Buckle	Black	Acetal	3/4 in.
207564	91760	Side Release Buckle	Black	Acetal	1-1/2 in.
207697	91526 BSR-DA	Side Release Double Adjust Buckle	Black	Acetal	1 in.
207701	91515 BSR	Side Release Buckle	Black	Acetal	1 in.
207702	91750 BSR	Side Release Buckle	Black	Acetal	1-1/2 in.
207703	91835 BSR	Side Release Buckle	Black	Acetal	2 in.



No. 207720

ACW CAM BUCKLES

ITEM #	STYLE #	COLOR	MATERIAL	WEBBING SIZE
207720	91390 CB	Black	Acetal	1 in.

YKK® WHEEL LOCKS

All plastic hardware.

ITEM #	STYLE #	DESCRIPTION	COLOR	WEBBING SIZE
585585	93838	Wheel Lock	Black	1 in.

YKK® is a registered trademark of YKK Corporation.



No. 586110

FASTEX® BARRELOC

Limitless applications include locking sleeping bag and parka hood draw strings. Can be used with either one or two cords.

ITEM #	COLOR	MATERIAL
586110	Black	Delrin®

Fastex® is a registered trademark of ITW. Delrin® is a registered trademark of E.I. Dupont de Nemours and Company, Inc.



No. 586430

FASTEX® CAM BUCKLE

This versatile buckle works with a camming action directly against webbing. It provides easy adjustment and high security at the same time and is suitable for a wide range of webbing applications. One-handed quick release.

ITEM #	COLOR	COLOR NUMBER	MATERIAL	WEBBING SIZE
586430	Black	525	Delrin®	1 in.

Fastex® is a registered trademark of ITW. Delrin® is a registered trademark of E.I. Dupont de Nemours and Company, Inc.



No. 585060

FASTEX® SIDE RELEASE BUCKLE

Can be used on backpacks, camera bags, and many other fastening applications.

ITEM #	COLOR	MATERIAL	WEBBING SIZE
585015	Black	Delrin®	3/4 in.
585016	White	Delrin®	3/4 in.
585030	Black	Delrin®	1 in.
585031	White	Delrin®	1 in.
585060	Black	Delrin®	1-1/2 in.
585070	Black	Nexcel	1-1/2 in.
585075	Black	Delrin®	2 in.

Fastex® is a registered trademark of ITW. Delrin® is a registered trademark of E.I. Dupont de Nemours and Company, Inc.



No. 585630

FASTEX® D-RING

These D-rings are perfect whenever a sturdy attachment point is required. Unlike metal D-rings, they won't rust or corrode. One inch D-ring available in double-bar version, which prevents D-ring from slipping or rotating within its webbing retainer.

ITEM #	COLOR	MATERIAL	WEBBING SIZE
585630	Black	Delrin®	1 in.
585660	Black	Delrin®	1-1/2 in.
585675	Black	Delrin®	2 in.

Fastex® is a registered trademark of ITW. Delrin® is a registered trademark of E.I. Dupont de Nemours and Company, Inc.



No. 586578

FASTEX® ELLIPSE CORDLOC

Provides an option for a lanyard tie down to assist in hand adjustments.

ITEM #	COLOR	MATERIAL
586578	Black	Delrin®

Fastex® is a registered trademark of ITW. Delrin® is a registered trademark of E.I. DuPont de Nemours and Company, Inc.



No. 585975

FASTEX® TRIGLIDE™ 3 BAR SLIDE

For sporting, recreational, luggage, medical, apparel and juvenile products. Extremely popular in the floatation and backpacking industries, these buckles can be used wherever webbing closures are needed. Useful in just about any application in which a variable length strap assembly is required.

ITEM #	STYLE #	COLOR	MATERIAL	WEBBING SIZE
585930	105-0100	Black	Delrin®	1 in.
585960	105-0150	Black	Delrin®	1-1/2 in.
585975	105-0200	Black	Delrin®	2 in.

Fastex® is a registered trademark of ITW. Triglides™ is a trademark of ITW. Delrin® is a registered trademark of E.I. DuPont de Nemours and Company, Inc.



No. 585775

FASTEX® LOOPLOC

Ideal for holding straps or webbing where no adjustment is needed.

ITEM #	STYLE #	COLOR	MATERIAL	WEBBING SIZE
585715		Black	Delrin®	1 in.
585760		Black	Delrin®	1-1/2 in.
585775	111-0200	Black	Delrin®	2 in.

Fastex® is a registered trademark of ITW. Delrin® is a registered trademark of E.I. DuPont de Nemours and Company, Inc.



No. 587300

FASTEX® SEWABLE GROMMET

Molded from a toughened nylon, the Sewable Grommet can be sewn directly to fabric or webbing. It will withstand heavy load and stress factors, yet always return to its original shape. It is unaffected by weather and will not snap or pull rope or cord running through it. Unaffected by ultraviolet degradation. Radio frequency bondable.

ITEM #	STYLE #	MATERIAL
587300	406-0000	Toughened Nylon

Fastex® is a registered trademark of ITW.



No. 586920

FASTEX® SHOCK CORD HOOK

These shock cord fasteners will not mar or scratch anything they touch. The entire unit is molded, which eliminates the necessity of using a metal crimp ring. They are also rust and corrosion proof. Operates under all weather conditions. Not affected by salt water.

ITEM #	STYLE #	COLOR	CORD SIZE	MATERIAL
586920	605-0250-5614	Black	1/4 in.	Delrin®
586930	605-0375	Black	5/16 in.	Delrin®

Fastex® is a registered trademark of ITW. Delrin® is a registered trademark of E.I. DuPont de Nemours and Company, Inc.



No. 585215

FASTEX® LADDERLOC™

Can be used on backpacks, camera bags, and many other fastening applications.

ITEM #	STYLE #	COLOR	MATERIAL	WEBBING SIZE
585215	154-0075	Black	Delrin®	3/4 in.
585270	104-2200	Black	Delrin®	2 in.
585283	154-3100-5614	Black	Acetal	1 in.

Fastex® is a registered trademark of ITW. Ladderloc™ is a trademark of ITW. Delrin® is a registered trademark of E.I. DuPont de Nemours and Company, Inc.



No. 207540

YKK® FASTENERS

All plastic hardware.



No. 207545

ITEM #	STYLE #	DESCRIPTION	COLOR	STANDARD PACKAGE	WEBBING SIZE
207540	LBS1	Easy Release Buckle	Black	100	1"
207543	LBRU1	Heavy Duty Quick Release Buckle	Black	1000	1"
207545	LBRU1.5	Heavy Duty Quick Release Buckle	Black	1000	1-1/2"
586089	LC055HD		Black	1500	

YKK® is a registered trademark of YKK Corporation.



No. 586089



No. 585310

SNAPHOOK – INTERLOCKING SNAPHOOK

Applications are similar to those of the side release buckle. However, the “tooth” design increases the overall strength.

ITEM #	STYLE #	COLOR	MATERIAL
585310	106-1000	Black	Delrin®

Delrin® is a registered trademark of E.I. Dupont de Nemours and Company, Inc.



No. 585430

SNAPHOOK – RETAINER

Other styles and colors available on special order.

ITEM #	STYLE #	COLOR	MATERIAL	SIZE
585430	108-0100	Black	Delrin®	1 in.
585460	108-0150	Black	Delrin®	1-1/2 in.
585475	108-0200-5614	Black	Delrin®	2 in.

Delrin® is a registered trademark of E.I. Dupont de Nemours and Company, Inc.



No. 585300

SNAPHOOK – STANDARD SNAPHOOK

Used most often for detachable shoulder straps.

ITEM #	STYLE #	COLOR	MATERIAL
585300	106-0000	Black	Delrin®

Delrin® is a registered trademark of E.I. Dupont de Nemours and Company, Inc.



No. 230717



No. 230959



No. 230995



No. 230792



No. 230991



No. 230997



No. 230795



No. 230993



No. 230998

DOT® BABY DURABLE™

An intermediate size snap fastener. Baby Durable provides firm snap action and strong holding power without being visually prominent on the end item.

ITEM #	STYLE #	DESCRIPTION	FINISH	SIZE	STANDARD PACKAGE
230717	94-XB-12105-4A	Cap	Nickel Plated		100
230792	94-XB-12205-4A	Socket	Nickel Plated		100
230794	94-BS-12402-1A	Post	Nickel Plated	3/16 in.	100
230795	94-BS-12404-2A	Post	Nickel Plated	1/4 in.	1000
230854	94-XB-12105-2B	Cap	Black Oxide		1000
230959	94-BS-12303-2A	Stud	Nickel Plated		1000
230991	94-X2-12108-2B	Cap	Black Oxide	3/16 in.	1000
230993	94-XB-12205-2C	Socket	Black Oxide		1000
230995	94-BS-12302-2C	Stud	Black Oxide		1000
230997	94-BS-12402-2C	Post	Black Oxide	3/16 in.	1000
230998	94-BS-12303-2C	Stud	Black Oxide		1000

DOT® COMMON SENSE® / CURTAIN FASTENERS

Curtain fasteners are available in brass lacquer, nickel or black finish. All studs have rust-resistant brass springs. Sold in full package lots of 100 and 1000 pieces.



ITEM #	STYLE #	DESCRIPTION	FINISH	SIZE	STANDARD PACKAGE	TOOLS PART #
230203	91-BS-78403-2E	Eyelet	Gilt		1000	450
230205	91-BS-78505-2D	Washer	Gilt		1000	
230207	91-BS-78507-2D	Back Plate	Gilt		1000	171
230220	91-XX-783157-2A	Turn Button Screw Stud	Nickel Plated	5/8 in.	1000	
230223	91-XB-78323-2E	Turn Button Double Height Two Screw Holes	Gilt		1000	
230226	91-XB-783247-2E	Turn Button Screw Stud	Gilt	5/8 in.	1000	9908
230228	91-XB-783247-2A	Turn Button Screw Stud	Nickel Plated	5/8 in.	1000	9908
230232	91-XB-78332-2E	Turn Button Double Prong	Gilt		1000	171
230234	91-XB-78333-2E	Turn Button Double Prong Double Height	Gilt		1000	171
230303	91-BS-78403-2A	Eyelet	Nickel Plated		1000	450
230305	91-BS-78505-2A	Washer	Nickel Plated		1000	
230307	91-BS-78507-2A	Back Plate	Nickel Plated		1000	171
230311	91-BS-78510-2A	Washer	Nickel Plated		1000	
230322	91-XB-78322-2A	Turn Button Two Screw Holes	Nickel Plated		1000	
230323	91-XB-78323-2A	Turn Button Double Height Two Screw Holes	Nickel Plated		1000	
230326	91-XB-783247-2A	Turn Button Screw Stud	Nickel Plated	5/8 in.	1000	9908
230327	91-XB-783257-2A	Turn Button Screw Stud	Nickel Plated	5/8 in.	1000	9908
230332	91-XB-78332-2A	Turn Button Double Prong	Nickel Plated		1000	171
230377	91-XB-78317-2G	Turn Button	Black Oxide		1000	
230378	91-BS-78502-2C	Back Plate	Black Oxide		1000	
230380	91-BS-78403-2G	Eyelet	Black Oxide		1000	450
230381	91-BS-78505-2C	Washer	Black Oxide		1000	
230385	91-BS-78404-2G	Eyelet (Long)	Black Oxide		1000	
230386	91-XB-78322-2G	Turn Button Two Screw Holes	Black Oxide		1000	
230389	91-XB-78333-2G	Turn Button Double Prong Double Height	Black Oxide		1000	171
230403	91-BS-78403-1E	Eyelet	Gilt		100	450
230405	91-BS-78505-1D	Washer	Gilt		100	
230422	91-XB-78322-1E	Turn Button Two Screw Holes	Gilt		100	
230423	91-XB-78323-1E	Turn Button Double Height Two Screw Holes	Gilt		100	
230426	91-XB-783247-1E	Turn Button Screw Stud	Gilt	5/8 in.	100	9908
230500	91-XX-783157-4A	Turn Button Screw Stud	Nickel Plated	5/8 in.	100	9908
230503	91-BS-78403-4A	Eyelet	Nickel Plated		100	450
230504	91-BS-78502-1A	Back Plate	Nickel Plated		100	
230505	91-BS-78505-4A	Washer	Nickel Plated		100	
230507	91-BS-78507-4A	Back Plate	Nickel Plated		100	171
230508	91-BS-78510-4A	Washer	Nickel Plated		100	
230509	91-PS-78511-49	Washer			100	
230520	91-XB-783247-1A	Turn Button Screw Stud	Nickel Plated	5/8 in.	100	9908
230522	91-XB-78322-4A	Turn Button Two Screw Holes	Nickel Plated		100	
230523	91-XB-78323-4A	Turn Button Double Height Two Screw Holes	Nickel Plated		100	
230526	91-XB-783247-4A	Turn Button Screw Stud	Nickel Plated	5/8 in.	100	9908
230527	91-XB-783257-1A	Turn Button Screw Stud	Nickel Plated	5/8 in.	100	9908
230532	91-XB-78332-4A	Turn Button Double Prong	Nickel Plated		100	171
230533	91-XB-78333-1A	Turn Button Double Prong Double Height	Nickel Plated		100	171
230534	91-BS-78404-4A	Eyelet (Long)	Nickel Plated		100	
230549	91-XB-78317-4A	Turn Button	Nickel Plated		100	
230580	91-BS-78403-1G	Eyelet	Black Oxide		100	450
230581	91-BS-78505-1C	Washer	Black Oxide		100	
230587	91-XB-78332-1G	Turn Button Double Prong	Black Oxide		100	171

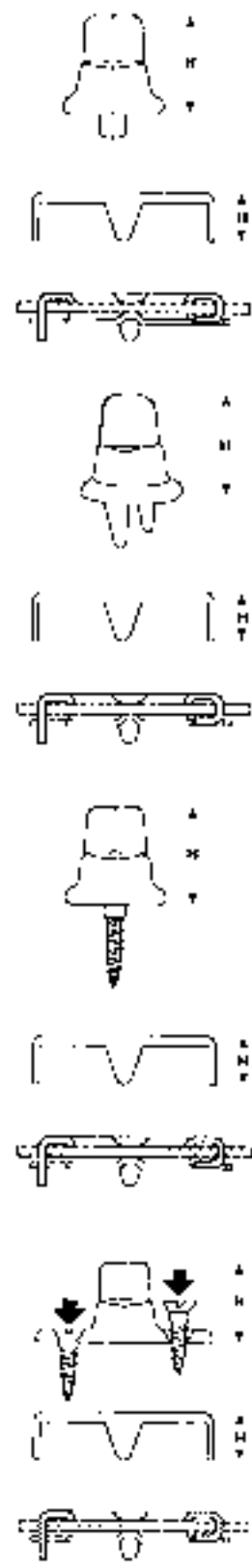

DOT® and Common Sense® are registered trademarks of Scovill, Inc. Durable™ is a trademark of Scovill, Inc.



No. 230932

DOT® DURABLE™ BLIND RIVET STUD

This component will provide the installer with a convenient method for securing a stud on hard surfaces such as steel, aluminum, tubing and panels.

Blind Rivet Studs are set in the same manner as typical pop rivets and eliminate the need for threading a stud into a pre-drilled hole or using a machine screw and nut combination. Used with the X2-10128 Button and XB-10224 Socket or similar combinations.

ITEM #	STYLE #	DESCRIPTION	FINISH	FOR USE ON	FOR USE WITH	STANDARD PACKAGE
230772	93-X8-10314-4A	Blind Rivet Stud	Nickel Plated/Stainless Steel Mandrel			100
230774	93-X8-10319-4A	Blind Rivet Stud	Nickel Plated/Stainless Steel Mandrel			100
230932	93-X8-10314-2A	Blind Rivet Stud	Nickel Plated/Stainless Steel Mandrel	Metal, Plastic	93-XB-10224-1A, 93-XB-10224-2A, 93-XB-10224-1C, 93-XB-10224-2C	1000

DOT® is a registered trademark of Scovill, Inc. Durable™ is a trademark of Scovill, Inc.



No. 229625

DOT® DURABLE™ ENAMEL

These ultraviolet stabilized enamel painted buttons are in popular demand. The generous color selection is designed to match or compliment a wide variety of today's most popular marine fabrics. Available in packs of 100 and 1000.

ITEM #	STYLE #	COLOR	STANDARD PACKAGE
229600	93-X2-10128-1534-1V	Dull Black	100
229601	93-X2-10128-1339-1V	Black	100
229602	93-X2-10128-1959-1V	White	100
229604	93-X2-10128-1487-1V	Lindy	100
229611	93-X2-10128-1290-1V	Medium Turquoise	100
229615	93-X2-10128-2104-1V	Mulberry	100
229617	93-X2-10128-2595-1V	Butternut Beige	100
229620	93-X2-10128-1473-1V	Dark Green	100
229622	93-X2-10128-9012-1V	Ranch Blue	100
229623	93-X2-10128-9002-1V	Captain Navy	100
229624	93-X2-10128-9031-1V	Walden White	100
229625	93-X2-10128-9000-1V	Cadet Grey	100
229629	93-X2-10128-9030-1V	Logo Red	100
229630	93-X2-10128-3209-1V	Winter Wheat	100
229632	93-X2-10128-9004-1V	Heather Beige	100
229650	93-X8-10128-1339-1V	Black	100
229651	93-X8-10128-1473-1V	Dark Green	100
229653	93-X8-10128-1534-1V	Dull Black	100
229654	93-X8-10128-1959-1V	White	100
229655	93-X8-10128-2234-1V	Foliage Green	100
229656	93-X8-10128-2424-1V	Regatta Red	100
229658	93-X8-10128-3209-1V	Winter Wheat	100
229660	93-X8-10128-9000-1V	Cadet Grey	100

ITEM #	STYLE #	COLOR	STANDARD PACKAGE
229661	93-X8-10128-9001-1V	Sea Grass Green	100
229662	93-X8-10128-9002-1V	Captain Navy	100
229664	93-X8-10128-9004-1V	Heather Beige	100
229665	93-X8-10128-9005-1V	Toast	100
229666	93-X8-10128-9006-1V	Taupe	100
229667	93-X8-10128-9007-1V	El Paso Tan	100
229668	93-X8-10128-9008-1V	Wood Chip	100
229669	93-X8-10128-9009-1V	Blue Marlin	100
229670	93-X8-10128-9010-1V	Serenity Rose	100
229671	93-X8-10128-9011-1V	Shingle Grey	100
229672	93-X8-10128-9012-1V	Ranch Blue	100
229675	93-X8-10128-9015-1V	Burnt Sugar	100
229676	93-X8-10128-9016-1V	Pumpkin Patch	100
229679	93-X8-10128-9019-1V	Mainline Blue	100
229681	93-X8-10128-9021-1V	Tavern Green	100
229682	93-X8-10128-9022-1V	Sharp Blue	100
229683	93-X8-10128-9023-1V	Banana Split	100
229684	93-X8-10128-9024-1V	Bahama Berry	100
229686	93-X8-10128-9026-1V	Oxford Wine	100
229688	93-X8-10128-9028-1V	Jericho Tan	100
229689	93-X8-10128-9029-1V	Grape Crush	100
229690	93-X8-10128-9030-1V	Logo Red	100
229693	93-X8-10128-9033-1V	Smoke Ring	100
229696	93-X8-10128-9036-1V	True Brown	100
229900	93-X2-10128-1534-2V	Dull Black	1000
229901	93-X2-10128-1339-2V	Black	1000
229902	93-X2-10128-1959-2V	White	1000

DOT® is a registered trademark of Scovill, Inc. Durable™ is a trademark of Scovill, Inc.



DOT® DURABLE™ MARINER™

High ultraviolet resistant plastic cap with a super-strong, self-piercing eyelet. Size matches the standard all-brass construction DOT Durable button.



No. 230881

ITEM #	STYLE #	COLOR	STANDARD PACKAGE
230674	93-XV-10150-1Y	Beige	100
230680	93-XV-10150-1V	White	100
230681	93-XV-10150-1X	Black	100
230880	93-XV-10150-2V	White	1000
230881	93-XV-10150-2X	Black	1000

DOT® is a registered trademark of Scovill, Inc. Durable™ and Mariner™ are trademarks of Scovill, Inc. Durable™ is a trademark of Scovill, Inc.



DOT® DURABLE™

Durable Fasteners are a medium-sized heavy-duty button type snap fastener. They are used largely by manufacturers of boat covers, porch curtains and industrial curtains. These fasteners are available in nickel or black finish on brass. Sold only in full package lots of 100, 1,000 or 10,000 pieces where indicated. Certain durable fasteners meet Government Specification MS-27980.

ITEM #	STYLE #	DESCRIPTION	FINISH	FOR USE WITH	HAND TOOLS PART NUMBER	MACHINE TOOLS PART NUMBER	SIZE	STANDARD PACKAGE
230501	93-XN-10135-1U	Snap Cap / Open Top Button / Pilot Hole Cap	Stainless Steel					100
230701	93-X2-10127-4A	Cap	Nickel Plated	93-XB-10224-1A, 93-XB-10224-2A, 93-XB-10224-1C, 93-XB-10224-2C	9936	1401	1/4 in. (H)	100
230702	93-X2-10128-4A	Cap	Nickel Plated	93-XB-10224-1A, 93-XB-10224-2A, 93-XB-10224-1C, 93-XB-10224-2C	9936	1401	11/64 in. (H)	100
230705	93-XB-10224-4A	Socket	Nickel Plated	93-X2-10127-1A, 93-X2-10127-2A, 93-X2-10127-1B, 93-X2-10127-2B, 93-X2-10128-1A, 93-X2-10128-2A, 93-X2-10128-1B, 93-X2-10128-2B, 93-X2-10128-2E	164	1410		100
230706	93-XX-10224-4A	Socket	Nickel Plated	93-X2-10127-1A, 93-X2-10127-2A, 93-X2-10127-1B, 93-X2-10127-2B, 93-X2-10128-1A, 93-X2-10128-2A, 93-X2-10128-1B, 93-X2-10128-2B, 93-X2-10128-2E	164	1410		100
230713	93-XX-103624-4A	Screw Stud	Nickel Plated/Steel Screw		169 N		3/8 in.	100
230715	93-XX-103627-4A	Screw Stud	Nickel Plated/Steel Screw		169 N		5/8 in.	100
230723	93-X8-109344-4A	Screw Stud	Nickel Plated/Stainless Steel Screw				3/8 in.	100
230727	93-BS-10370-4A	Stud	Nickel Plated	93-BS-10412-1A, 93-BS-10412-2A, 93-BS-10412-1C, 93-BS-10412-2C	164	1412		100
230728	93-XB-10342-4A	Gypsy Stud	Nickel Plated	93-XB-10224-1A, 93-XB-10224-2A, 93-XB-10224-1C, 93-XB-10224-2C		9557		100
230737	93-XB-103934-4A	Screw Stud	Nickel Plated		169 N			100
230739	93-X8-103934-4A	Screw Stud	Nickel Plated/Stainless Steel Screw		169 N		3/8 in.	100
230740	93-BS-10412-4A	Post	Nickel Plated	93-BS-10370-1A, 93-BS-10370-2A, 93-BS-10370-1C, 93-BS-10370-2C	9936	1407	1/4 in. (H)	100
230741	93-BS-10413-4A	Post	Nickel Plated	93-BS-10370-1A, 93-BS-10370-2A, 93-BS-10370-1C, 93-BS-10370-2C	9936	1407	5/16 in. (H)	100
230743	93-BS-10414-1A	Post	Nickel Plated	93-BS-10370-1A, 93-BS-10370-2A, 93-BS-10370-1C, 93-BS-10370-2C	9936	1407	3/8 in. (H)	100
230744	93-BS-10379-4A	Stud	Nickel Plated					100

ITEM #	STYLE #	DESCRIPTION	FINISH	FOR USE WITH	HAND TOOLS PART NUMBER	MACHINE TOOLS PART NUMBER	SIZE	STANDARD PACKAGE
230749	93-XB-107084-1A	Screw Stud	Nickel Plated		169 N		3/8 in.	100
230753	93-XB-107087-1A	Screw Stud	Nickel Plated		169 N		5/8 in.	100
230756	93-XB-103937-4A	Screw Stud	Nickel Plated		169 N		5/8 in.	100
230758	93-X8-103937-4A	Screw Stud	Nickel Plated/Stainless Steel Screw		169 N		5/8 in.	100
230760	93-X8-103938-1A	Screw Stud	Nickel Plated/Stainless Steel Screw	93-XB-10224-1A, 93-XB-10224-2A, 93-XB-10224-1C, 93-XB-10224-2C, 93-XX-10224-2C, 93-XX-10224-1A, 93-XX-10224-2A	169 N		1 in.	100
230764	93-X8-103015-4A	Screw Stud	Nickel Plated/Stainless Steel Screw		169 N		7/16 in.	100
230765	93-X8-109347-4A	Screw Stud	Nickel Plated/Stainless Steel Screw				5/8 in.	100
230766	93-X8-103017-4A	Screw Stud	Nickel Plated/Stainless Steel Screw		169 N		5/8 in.	100
230768	93-X8-103025-4A	Screw Stud	Nickel Plated/Stainless Steel Screw		169 N		7/16 in.	100
230769	93-X8-103027-4A	Screw Stud	Nickel Plated/Stainless Steel Screw		169 N		5/8 in.	100
230780	93-X2-10128-1B	Cap	Black Oxide	93-XB-10224-1A, 93-XB-10224-2A, 93-XB-10224-1C, 93-XB-10224-2C	9936	1401	11/64 in. (H)	100
230781	93-XB-10224-1C	Socket	Black Oxide	93-X2-10127-1A, 93-X2-10127-2A, 93-X2-10127-1B, 93-X2-10127-2B, 93-X2-10128-1A, 93-X2-10128-2A, 93-X2-10128-1B, 93-X2-10128-2B, 93-X2-10128-2E	164	1410		100
230782	93-B5-10370-1C	Stud	Black Oxide	93-B5-10413-1A, 93-B5-10413-2A	164	1412		100
230783	93-B5-10412-4C	Post	Black Oxide	93-B5-10370-1A, 93-B5-10370-2A, 93-B5-10370-1C, 93-B5-10370-2C	9936	1407	1/4 in. (H)	100
230784	93-X2-10127-1B	Cap	Black Oxide	93-XB-10224-1A, 93-XB-10224-2A, 93-XB-10224-1C, 93-XB-10224-2C	9936	1401	1/4 in. (H)	100
230787	93-XX-10224-2C	Socket	Black Oxide	93-X2-10127-1A, 93-X2-10127-2A, 93-X2-10127-1B, 93-X2-10127-2B, 93-X2-10128-1A, 93-X2-10128-2A, 93-X2-10128-1B, 93-X2-10128-2B, 93-X2-10128-2E	164	1410		1000
230850	93-X8-109344-2A	Screw Stud	Nickel Plated/Stainless Steel Screw				3/8 in.	1000
230851	93-X8-109347-2A	Screw Stud	Nickel Plated/Stainless Steel Screw				5/8 in.	1000
230863	93-B5-10379-3C	Stud	Nickel Plated					10000
230888	93-X2-10127-2B	Cap	Black Oxide	93-XB-10224-1A, 93-XB-10224-2A, 93-XB-10224-1C, 93-XB-10224-2C	9936	1401	1/4 in. (H)	1000
230890	93-X2-10128-3A	Cap	Nickel Plated				11/64 in. (H)	10000
230891	93-XB-10224-3A	Socket	Nickel Plated					10000
230892	93-B5-10370-3A	Stud	Nickel Plated					10000
230893	93-B5-10412-3A	Post	Nickel Plated				1/4 in. (H)	10000
230895	93-B5-10412-2C	Post	Black Oxide	93-B5-10370-1A, 93-B5-10370-2A, 93-B5-10370-1C, 93-B5-10370-2C	9936	1407	1/4 in. (H)	1000
230896	93-XB-10224-2C	Socket	Black Oxide	93-X2-10127-1A, 93-X2-10127-2A, 93-X2-10127-1B, 93-X2-10127-2B, 93-X2-10128-1A, 93-X2-10128-2A, 93-X2-10128-1B, 93-X2-10128-2B, 93-X2-10128-2E	164	1410		1000
230897	93-B5-10370-2C	Stud	Black Oxide	93-B5-10413-1A, 93-B5-10413-2A	164	1412		1000
230898	93-X2-10128-2B	Cap	Black Oxide	93-XB-10224-1A, 93-XB-10224-2A, 93-XB-10224-1C, 93-XB-10224-2C	9936	1401	11/64 in. (H)	1000
230899	93-X2-10127-2A	Cap	Nickel Plated	93-XB-10224-1A, 93-XB-10224-2A, 93-XB-10224-1C, 93-XB-10224-2C	9936	1401	1/4 in. (H)	1000
230900	93-X2-10128-2A	Cap	Nickel Plated	93-XB-10224-1A, 93-XB-10224-2A, 93-XB-10224-1C, 93-XB-10224-2C	9936	1401	11/64 in. (H)	1000
230901	93-XB-10224-2A	Socket	Nickel Plated	93-X2-10127-1A, 93-X2-10127-2A, 93-X2-10127-1B, 93-X2-10127-2B, 93-X2-10128-1A, 93-X2-10128-2A, 93-X2-10128-1B, 93-X2-10128-2B, 93-X2-10128-2E	164	1410		1000
230905	93-B5-10370-2A	Stud	Nickel Plated	93-B5-10412-1A, 93-B5-10412-2A, 93-B5-10412-1C, 93-B5-10412-2C	164	1412		1000
230911	93-X8-103934-2A	Screw Stud	Nickel Plated/Stainless Steel Screw		169 N		3/8 in.	1000

ITEM #	STYLE #	DESCRIPTION	FINISH	FOR USE WITH	HAND TOOLS PART NUMBER	MACHINE TOOLS PART NUMBER	SIZE	STANDARD PACKAGE
230912	93-BS-10412-2A	Post	Nickel Plated	93-BS-10370-1A, 93-BS-10370-2A, 93-BS-10370-1C, 93-BS-10370-2C	9936	1407	1/4 in. (H)	1000
230913	93-XX-103624-2A	Screw Stud	Nickel Plated/Steel Screw		169 N		3/8 in.	1000
230916	93-BS-10379-2A	Stud	Nickel Plated					1000
230917	93-XX-10224-2A	Socket	Nickel Plated	93-X2-10127-1A, 93-X2-10127-2A, 93-X2-10127-1B, 93-X2-10127-2B, 93-X2-10128-1A, 93-X2-10128-2A, 93-X2-10128-1B, 93-X2-10128-2B, 93-X2-10128-2E	164	1410		1000
230918	93-XB-103934-2A	Stud	Nickel Plated		169 N			1000
230921	93-XB-103937-2A	Screw Stud	Nickel Plated		169 N		5/8 in.	1000
230922	93-XX-103627-2A	Screw Stud	Nickel Plated/Steel Screw		169 N		5/8 in.	1000
230923	93-X8-103937-2A	Screw Stud	Nickel Plated/Stainless Steel Screw		169 N		5/8 in.	1000
230924	93-BS-10413-2A	Post	Nickel Plated	93-BS-10370-1A, 93-BS-10370-2A, 93-BS-10370-1C, 93-BS-10370-2C	9936	1407	5/16 in. (H)	1000
230926	93-BS-10414-2A	Post	Nickel Plated	93-BS-10370-1A, 93-BS-10370-2A, 93-BS-10370-1C, 93-BS-10370-2C	9936	1407	3/8 in. (H)	1000
230930	93-XB-10231-2A	Socket	Nickel Plated	93-X2-10127-1A, 93-X2-10127-2A, 93-X2-10127-1B, 93-X2-10127-2B, 93-X2-10128-1A, 93-X2-10128-2A, 93-X2-10128-1B, 93-X2-10128-2B, 93-X2-10128-2E	164	1410		1000
230931	93-X8-103938-2A	Screw Stud	Nickel Plated/Stainless Steel Screw		169 N		1 in.	1000
230934	93-X8-103015-2A	Screw Stud	Nickel Plated/Stainless Steel Screw		169 N		7/16 in.	1000
230935	93-XB-10342-2A	Gypsy Stud	Nickel Plated	93-XB-10224-1A, 93-XB-10224-2A, 93-XB-10224-1C, 93-XB-10224-2C		9557		1000
230936	93-X8-103017-2A	Screw Stud	Nickel Plated/Stainless Steel Screw		169 N		5/8 in.	1000
230938	93-X8-103025-2A	Screw Stud	Nickel Plated/Stainless Steel Screw		169 N		7/16 in.	1000
230939	93-X8-103027-2A	Screw Stud	Nickel Plated/Stainless Steel Screw		169 N		5/8 in.	1000
231063	93-BS-10123-1A	Veltex Carpet Snap Socket	Nickel Plated					100
231117	93-X8-107044-1A	Screw Stud	Nickel Plated/Stainless Steel Screw					100

DOT® is a registered trademark of Scovill, Inc. Durable™ is a trademark of Scovill, Inc.



No. 230655



No. 230657



No. 230659



No. 230666



No. 230667



No. 231008

DOT® DURABLE™ STAINLESS

ITEM #	STYLE #	DESCRIPTION	FINISH	SIZE	STANDARD PACKAGE
230655	93-X8-10127-1A	Cap	Nickel Plated/Stainless Steel Post		100
230657	93-XN-10224-4U	Socket	Stainless Steel		100
230659	93-XN-103934-1U	Screw Stud	Stainless Steel	3/8 in.	100
230661	93-XN-103937-1U	Screw Stud	Stainless Steel	5/8 in.	100
230664	93-XN-10128-4U	Cap	Stainless Steel		100
230666	93-NS-10370-1U	Stud	Stainless Steel		100
230667	93-NS-10412-1U	Post	Stainless Steel		100
230669	93-X8-10128-1A	Cap	Nickel Plated/Stainless Steel Post		100
230670	93-XN-10127-1U	Cap	Stainless Steel		100
230967	93-X8-10127-2A	Cap	Nickel Plated/Stainless Steel Post		1000
230969	93-XN-10224-2U	Socket	Stainless Steel		1000
230970	93-XN-103934-2U	Screw Stud	Stainless Steel	3/8 in.	1000
230971	93-XN-103937-2U	Screw Stud	Stainless Steel	5/8 in.	1000
230974	93-XN-10128-2U	Cap	Stainless Steel		1000
230976	93-NS-10370-2U	Stud	Stainless Steel		1000
230977	93-NS-10412-2U	Post	Stainless Steel		1000
230981	93-X8-10128-2A	Cap	Nickel Plated/Stainless Steel Post		1000
231000	93-XN-10127-2U	Cap	Stainless Steel		1000
231008	93-XN-10616-2U	Buckle	Stainless Steel		1000

DOT® is a registered trademark of Scovill, Inc. Durable™ is a trademark of Scovill, Inc.

WASHER – SCREW STUD

ITEM #	MATERIAL	STANDARD PACKAGE
296005	Nylon	1000



No. 231085

FASNAP® RIB TREE BOLSTER FASTENERS

This 3/4 inch panel fastener with ribbed shank assures easy installation and secure hold. One ribbed end is pushed into primary panel to retain clip. Second panel is pushed down onto projecting ribbed end to complete the assembly.

ITEM #	DESCRIPTION
231085	3/4 in. double end clip with inner stop 1/2 in. x 7/8 in.

FASNAP® is a registered trademark of The FASNAP Corporation.



No. 230671



No. 230696



No. 231026



No. 230691



No. 230767



No. 231027



No. 230694



No. 230960



No. 231096

FASNAP® FASTENERS

High rust and corrosion resistant button, normal action socket, stud, and eyelet. The button and eyelet are, in many instances, able to self-pierce through multiple layers of fabric. All four components are interchangeable with nickel-plated brass screw studs or other snap fasteners and tools, eliminating special die requirements.

ITEM #	STYLE #	DESCRIPTION	FINISH	STANDARD PACKAGE	TYPE
230671	BNCT705916	Screw Stud	Nickel/Brass Stud, Stainless Steel Screw	100	1/2 in. #8 TEK® Screw
230688	SSC4650AR	Button	Stainless Steel	100	
230691	SSC4650B	Socket	Stainless Steel	100	
230694	SSC4650C	Stud	Stainless Steel	100	
230696	SSC4647D	Post	Stainless Steel	100	
230767	BNSC705921	Screw Stud	Stainless Steel	100	5/8 in. #10 Screw
230960	SS4650AR	Cap	Stainless Steel	1000	
230963	SSC4650B/SS4650B	Socket	Stainless Steel	1000	
230966	SSC4650C/SS4650C	Stud	Stainless Steel	1000	
230968	SC4647D/SS4647D	Post	Stainless Steel	1000	
231026	BN4647AR	Cap	Nickel Plated	1000	
231027	BN4647B	Socket	Nickel Plated	1000	
231096	BHST705916	Screw Stud	Nickel/Brass Stud, Stainless Steel Screw	100	1/2 in. #8 Hardened TEK® Screw

FASNAP® is a registered trademark of The FASNAP Corporation. TEK® is a registered trademark of ITW Buildex Corp.

DOT® LIFT-THE-DOT®

Featured below are styles available, complete with parts indicated. Sold only in full package lots of 100 pieces or 1000 pieces. Lift-The-Dot Fasteners are available in nickel or black finish. Certain Lift-The-Dot fasteners meet Government Specification MS-27977. Strong and heavy duty, Lift-The-Dot fasteners lock on three sides and are opened by lifting the fourth side where the Dot and the Lift-The-Dot trademark appear.



No. 230601



No. 230608



No. 230610



No. 230620



No. 230628



No. 230630



No. 230636



No. 230637



No. 230638

ITEM #	STYLE #	DESCRIPTION	FINISH	FOR USE ON	FOR USE WITH	HAND TOOLS PART NUMBER	MACHINE TOOLS PART NUMBER	SCREW SIZE	STANDARD PACKAGE
230601	90-XX-16205-4A	Socket	Nickel Plated	Canvas	90-BS-16506-1A, 90-BS-16506-2A, 90-BS-16506-2C		1454		100
230602	90-XX-16206-4A	Socket	Nickel Plated	Canvas	90-BS-16506-1A, 90-BS-16506-2A, 90-BS-16506-2C		1454		100
230603	90-XB-163174-1A	Screw Stud	Nickel Plated	Wood		169B		3/8 in.	100
230605	90-XB-163177-4A	Screw Stud	Nickel Plated	Wood		169B		5/8 in.	100
230608	90-BS-16349-1A	Stud	Nickel Plated	Canvas	90-BS-16501-1A, 90-BS-16501-2A	171			100
230610	90-XB-16358-4A	Stud	Nickel Plated	Canvas	90-BS-16509-1A, 90-BS-16509-2A, 90-BS-16509-2C	9940	1456		100
230618	90-XB-163624-1A	Screw Stud	Nickel Plated/Brass Screw	Metal		169B		3/8 in.	100
230620	90-X8-163606-4A	Screw Stud	Nickel Plated/Stainless Steel Screw	Wood, Metal, Plastic		169B		1/2 in.	100
230624	90-X8-163604-4A	Screw Stud	Nickel Plated/Stainless Steel Screw	Wood		169B		3/8 in.	100
230628	90-XB-16347-1A	Stud with 2-Hole Plate	Nickel Plated	Wood					100
230630	90-X8-16376-1A	Windshield Clip (3/4 in.)	Nickel Plated/Stainless Steel Clip	Wood					100
230633	90-X8-16377-1A	Windshield Clip (7/8 in.)	Nickel Plated/Stainless Steel Clip	Wood					100
230636	90-BS-16501-1A	Washer	Nickel Plated	Canvas	90-BS-16349-1A, 90-BS-16349-2A		8042		100
230637	90-BS-16506-4A	Back Plate	Nickel Plated	Canvas	90-XX-16205-1A, 90-XX-16205-2A, 90-XX-16205-1B, 90-XX-16205-2B, 90-XX-16206-1A, 90-XX-16206-2A, 90-XX-16206-2B				100
230638	90-BS-16509-4A	Washer	Nickel Plated	Canvas	90-XB-16358-1A, 90-XB-16358-2A, 90-XB-16358-2B		1457		100
230647	90-XX-16206-2A	Socket	Nickel Plated	Canvas	90-BS-16506-1A, 90-BS-16506-2A, 90-BS-16506-2C		1454		1000
230649	90-XX-16205-1B	Socket	Black Oxide	Canvas	90-BS-16506-1A, 90-BS-16506-2A, 90-BS-16506-2C		1454		100
230651	90-XB-16358-2B	Stud	Black Oxide	Canvas	90-BS-16509-1A, 90-BS-16509-2A, 90-BS-16509-2C		1456		1000
230652	90-BS-16509-2C	Washer	Black Oxide	Canvas	90-XB-16358-1A, 90-XB-16358-2A, 90-XB-16358-2B		1457		1000
230654	90-XX-16206-2B	Socket	Black Oxide				1454		1000
230656	90-PS-16510-49	Washer		Canvas	90-XX-16205-1A, 90-XX-16205-2A, 90-XX-16205-1B, 90-XX-16205-2B, 90-BS-16506-1A, 90-BS-16506-2A, 90-BS-16506-2C				100
230940	90-XX-16205-2A	Socket	Nickel Plated	Canvas	90-BS-16506-1A, 90-BS-16506-2A, 90-BS-16506-2C		1454		1000
230944	90-XB-16358-2A	Stud	Nickel Plated	Canvas	90-BS-16509-1A, 90-BS-16509-2A, 90-BS-16509-2C	9940	1456		1000

ITEM #	STYLE #	DESCRIPTION	FINISH	FOR USE ON	FOR USE WITH	HAND TOOLS PART NUMBER	MACHINE TOOLS PART NUMBER	SCREW SIZE	STANDARD PACKAGE
230951	90-BS-16506-2A	Back Plate	Nickel Plated	Canvas	90-XX-16205-1A, 90-XX-16205-2A, 90-XX-16205-1B, 90-XX-16205-2B, 90-XX-16206-1A, 90-XX-16206-2A, 90-XX-16206-2B	9940	1455		1000
230952	90-BS-16509-2A	Washer	Nickel Plated	Canvas	90-XB-16358-1A, 90-XB-16358-2A, 90-XB-16358-2B		1457		1000
230955	90-X8-163606-2A	Screw Stud	Nickel Plated/Stainless Steel Screw	Wood, Metal, Plastic		169B		1/2 in.	1000
230956	90-PS-16510-29	Washer		Canvas	90-XX-16205-1A, 90-XX-16205-2A, 90-XX-16205-1B, 90-XX-16205-2B, 90-BS-16506-1A, 90-BS-16506-2A, 90-BS-16506-2C				1000
230978	90-XX-16205-2B	Socket	Black Oxide	Canvas	90-BS-16506-1A, 90-BS-16506-2A, 90-BS-16506-2C		1454		1000
230979	90-BS-16506-2C	Back Plate	Black Oxide	Canvas	90-XX-16205-1A, 90-XX-16205-2A, 90-XX-16205-1B, 90-XX-16205-2B, 90-XX-16206-1A, 90-XX-16206-2A, 90-XX-16206-2B		1455		1000
231120	90-XB-16368-1A	Stud	Nickel Plated	Canvas, Metal, Plastic	90-XX-16205-1A, 90-XX-16205-2A, 90-XX-16205-1B, 90-XX-16205-2B, 90-XX-16206-1A, 90-XX-16206-2A, 90-XX-16206-1B, 90-XX-16206-2B, 90-XX-16206-2E	9940			100
231125	90-X8-163607-1A	Screw Stud	Nickel Plated/Stainless Steel Screw	Metal, Plastic	X8-16205, X8-16206	169B			100

DOT® and Lift-The-Dot® are registered trademarks of Scovill, Inc.

FASTENER – WINDSHIELD CLIP



Top Snap Fasteners snap over a boat windshield channel, eliminating need for drilling holes through the windshield. The clip portion of the Top Snap Fastener is made of stainless steel to resist corrosion. Socket portion is made of nickel-plated brass. DOT® Durable™ Button and Sockets are inserted through fabric top, then snapped onto the Top Snap Fastener.



No. 230745



No. 230909

ITEM #	STYLE #	DESCRIPTION	FINISH	SIZE	STANDARD PACKAGE
230738	93-XX-10388-1A	Windsheild Clip	Nickel Plated/Stainless Steel Clip	3/4 in. x 9/16 in.	100
230745	93-XX-10391-1A	Windsheild Clip	Nickel Plated/Stainless Steel Clip	7/8 in. x 9/16 in.	100
230909	93-XX-10388-2A	Windsheild Clip	Nickel Plated/Stainless Steel Clip	3/4 in. x 9/16 in.	1000
230910	93-XX-10391-2A	Windsheild Clip	Nickel Plated/Stainless Steel Clip	7/8 in. x 9/16 in.	1000

DOT® is a registered trademark of Scovill, Inc. Durable™ is a trademark of Scovill, Inc.

DOT® PULL-THE-DOT®



No. 230800

The Pull-The-Dot Fastener is a side-locking snap fastener, similar to the Durable™ Glove-style fastener, except for its “built-in” locking feature. This fastener will withstand extreme pressure on three sides without unlocking, yet will release instantly on the fourth side if one “pulls the dot” embossed on one side of the button. Pull-The-Dots have no sharp edges or protrusions to tear or mar the fabric to be fastened.



No. 230801

Since the socket opens only on one side, care must be taken that the button and socket are set so that the fastener can be opened at the desired position.



No. 230802



No. 230823

ITEM #	STYLE #	DESCRIPTION	FINISH	STANDARD PACKAGE
230799	92-BS-18303-2C	Stud	Black Oxide	1000
230800	92-XE-18100-A4A	Cap	Nickel	100
230801	92-XX-18201-4A	Socket	Nickel	100
230802	92-BS-18303-4A	Stud	Nickel	100
230803	92-X8-183074-1A	Stud	Nickel/Stainless Steel Screw	100
230819	92-XE-18100-A2B	Cap	Black Oxide	1000
230820	92-XE-18100-A2A	Cap	Nickel	1000
230821	92-XX-18201-2A	Socket	Nickel	1000
230822	92-BS-18303-2A	Stud	Nickel	1000
230823	92-X8-183074-2A	Stud	Nickel/Stainless Steel Screw	1000
230842	92-XX-18201-2C	Socket	Black Oxide	1000

DOT® and Pull-The-Dot® are registered trademarks of Scovill, Inc. Durable™ is a trademark of Scovill, Inc.



No. 223507



No. 223560



No. 223558



No. 275577

DOT® PULL-THE-DOT® DIES

ITEM #	STYLE #	FOR USE WITH
223507	1407	BS-10412 eyelet
223558	9758	XE-18100 button
223560	8059	XX-18201 socket
275577	9760	BS-18303 stud



No. 231014



No. 231015



No. 231016

SNAPFAST® SYSTEM

The Snapfast fastening system offers an alternative to traditional all-metal directional fasteners. This non-corrosive directional fastening system has no moving parts and unlocks from one direction only. The sockets and studs are manufactured from heavy-duty polyacetal with a UV stabilizer. Snapfast's stainless steel pronged cap self-pierces most industrial fabrics and installs easily using hand tools.

ITEM #	STYLE #	DESCRIPTION	COLOR	FINISH	STANDARD PACKAGE
231014	SNPTSTB	Socket	Black		100
231015	SNPFSTC	Stud	Black		100
231016	SNPFSTA	Pronged Cap		Stainless Steel	100
231045	SNPFSTLA	Long Pronged Cap		Stainless Steel	100
231046	SNPFSTBW	Socket	White		100
231047	SNPFSTCW	Stud	White		100

Snapfast® is a registered trademark of The FASNAP Corporation.



No. 289264



No. 289270



No. 289281



No. 289284

STAYPUT™ FASTENERS

"Stayput" for a secure and corrosion free fastening solution. Stayput canvas fasteners have no springs to corrode or jam. They are manufactured from UV stabilized nylon and acetyl compounds. Originally designed for the marine market, are now used extensively in all areas of fabric fastening.

ITEM #	STYLE #	DESCRIPTION	COLOR
289262	48B	Tent Wall J-Hook	Black
289263	48W	Tent Wall J-Hook	White
289264	87B	Attach Knob	Black
289265	86W	Attach Knob	White
289266	37B	Horizontal Single	Black
289268	37W	Horizontal Single	White
289270	34B	Vertical Single	Black
289272	34W	Vertical Single	White
289273	35W	Vertical Double	White
289276	40W	Canvas to Canvas Double	White
289280	50W	Tent Wall Hook	White
289281	50B	Tent Wall Hook	Black
289283	70W	Ultimate Shock Cord Clip	White
289284	70B	Ultimate Shock Cord Clip	Black
289292	71W	Ultimate Clip Back	White
289293	71B	Ultimate Clip Back	Black

Stayput™ is a trademark of Stayput Fasteners.



No. 231065



No. 231077

SNAD® PRESSURE SENSITIVE YKK® FASTENERS

The YKK SNAD fastener is a durable, innovative snap fastener that attaches to various substrates and surfaces using a sophisticated, and proven adhesive. This eliminates having to drill holes in surfaces to mount the fastener.

ITEM #	STYLE #	DESCRIPTION	COLOR	DIAMETER	SIZE
231065	PG3-0000-A01	Domed Stud	Black	1-9/16 in.	
231068	PG1-0000-839	Domed Socket	White	1-9/16 in.	
231069	PG3-0000-839	Domed Stud	White	1-9/16 in.	
231071	PG1-0000-A01	Domed Socket	Black	1-9/16 in.	
231073	QL7-0000-QP3	Flexible Base Stud	White		
231075	QL7-0000-PX7	Flexible Base Stud	Gray		
231076	TP9-0000-TVO	Flexible Base Stud	Clear		25 mm
231077	QL7-0000-QK1	Flexible Base Stud	Black		
231078	TR5-0000-TVO	Flexible Base Socket	Clear		25 mm
231079	TT5-0000-TVO	Flexible Base Stud	Clear		40 mm
231107	QW9-0000-839	Domed Stud	White	1 in.	
231108	QW9-0000-A01	Domed Stud	Black	1 in.	

YKK® and SNAD® are registered trademarks of YKK Corporation of America.



No. 228180



No. 228181



No. 228186



No. 228187

MENAX® SNAP FASTENERS

This efficient hardware provides a heavy-duty, corrosion resistant fastening system. Menax Snap fasteners provide a durable and easy to handle option for fabric to fabric, and fabric to hard surface applications.

ITEM #	STYLE #	DESCRIPTION	COLOR	FINISH	MATERIAL	SIZE	STANDARD PACKAGE
228180	23.2010.71.21	Snap Fastener with Threaded Washer Nut	White		Polyacetal (POM)		100
228181	23.2020.71.21	Fabric to Fabric Post with Threaded Washer Nut	Black		Polyacetal (POM)		100
228182	23.2010.79.21	Snap Fastener with Threaded Washer Nut	White		Polyacetal (POM)		100
228183	23.2020.79.21	Fabric to Fabric Post with Threaded Washer Nut	Black		Polyacetal (POM)		100
228184	23..2108.21.21	Machine Screw Post with Washer/Nut		Nickel Plated	Brass	8 mm	100
228185	81.2002.19.01	Driver Key					
228186	23.2112.21.21	Machine Screw Post with Washer/Nut		Nickel Plated	Brass	12 mm	100
228187	23.2325.21.21	Wood Screw Post with Washer		Nickel Plated	Brass	12 mm	100
228188	23.2425.18.21	Post			Stainless Steel	15 mm	100

Menax® is a registered trademark of American Keder, Inc.



No. 251997

SUCTION CUP

A solution to your "no hardware" needs, this giant suction cup has 60 pounds of holding power. Secures to any smooth surface. Ideal for "rack storage" boat covers.

ITEM #	STYLE #	CORD SIZE	SIZE	STANDARD PACKAGE	STRETCH SIZE
251997	CT6	6 in.	3-1/2 in.	1	11 in.



No. 287820

BOAT TOP FITTINGS – ALUMINUM – BOAT COVER SOCKET

Cast aluminum alloy. Ideal to keep boat covers from sagging. Use with Trivantage® Fiberglass Bow Slats to support boat cover. Two screw holes drilled for No. 8 screw.

ITEM #	STYLE #	SIZE	STANDARD PACKAGE
287820	440-22	5/8 in. height, 1-7/8 in. x 1/2 in opening, 3-1/2 in. x 7/8 in. base	10

Trivantage® is a registered trademark of Glen Raven, Inc.



No. 281104



No. 282143



No. 282142



No. 282150

BOAT TOP FITTINGS – ALUMINUM – SLIP FIT EYE END

With stainless steel set screw.

ITEM #	STYLE #	FOR	STANDARD PACKAGE
281104*	424-4S	1/2 in. pipe, 7/8 in. OD tube	10
281105	424-4S	1/2 in. pipe, 7/8 in. OD tube	10
282142	422-3S	3/8 in. pipe	10
282143	433-7S	3/4 in. OD tube	10
282150	438-10S	1 in. OD tube	10

*281104 - With square head set screw.



No. 282146

BOAT TOP FITTINGS – ALUMINUM – INSERT EYE END

When inserted, flange of Eye End is flush with outside of tubing. Must be secured by means of crimping tool or rivet. For use with Deck Mounting and Angle Hinges.



No. 282149

ITEM #	STYLE #	FOR	STANDARD PACKAGE
282146	4434-12	3/4 in. OD tube, 5/8 in. ID tube	10
282149	4436-16	7/8 in. ID tube, 3/4 in. ID tube	10



No. 284048

BOAT TOP FITTINGS – ALUMINUM – ANGLE HINGE

10° angle, with stainless steel screw.

ITEM #	STYLE #	PROJECTION	STANDARD PACKAGE
284048	487-513	1 in.	10



No. 284047

BOAT TOP FITTINGS – ALUMINUM – DECK MOUNTING HINGE



No. 284049

ITEM #	STYLE #	PROJECTION	STANDARD PACKAGE
284047	477-2A	3/4 in.	10
284049	478-523	1-1/8 in.	10



No. 284050

BOAT TOP FITTINGS – ALUMINUM – PONTON DECK HINGE

90° aluminum deck hinge designed for use on pontoon boats with 1 inch square aluminum tubing. Made from 6063-T6 extruded aluminum with satin anodization for uniform finish. Requires a 1/4 inch diameter pull pin.

ITEM #	STYLE #	STANDARD PACKAGE
284050	BH76	10



No. 287650

BOAT TOP FITTINGS – ALUMINUM – JAW SLIDE

Equipped with stainless set screw, and round head machine screw.

ITEM #	STYLE #	FOR	STANDARD PACKAGE
287650	468-70J	1 in. OD tube	10
287688	458-5042	1/2 in. pipe, 7/8 in. OD tube	10



No. 287688



No. 287647

BOAT TOP FITTINGS – ALUMINUM – PONTON JAW SLIDE

Designed for use on pontoon boats with 1 inch square aluminum tubing. Made from 6063T6 extruded aluminum with satin anodization for uniform finish. A 1/4 – 20 x 5/16 inch stainless steel socket set screw, a 1/4 – 20 stainless steel hex head shoulder bolt and a nylok hex nut are included.

ITEM #	STYLE #	FOR	STANDARD PACKAGE
287647	BH74	1 in. square tube	10



No. 287642

BOAT TOP FITTINGS – ALUMINUM – PONTON H BRACKET

Designed for use on pontoon boats with 1-1/4 inch square aluminum tubing. Includes bolt and nut.

ITEM #	DESCRIPTION	FOR	STANDARD PACKAGE
287640	Standard Thin Wall	1 in. square tube	1
287642	Tall	1 in. square tube	10



No. 239960

BOAT TOP FITTINGS – ALUMINUM – TOWER CLAMP

These Tower Clamps with knobs are designed for use with eye ends to attach Bimini frame hardware to a tower on large cruisers and sport fishing vessels.

ITEM #	STYLE #	SIZE	STANDARD PACKAGE
239959	200960	1-1/2 in.	10
239960	200980	2-1/8 in.	10
239961	200999	2-3/8 in.	10

MARINE TUBING – ALUMINUM

This bright dip anodized, drawn aluminum tubing is ideal. Less than full cartons are not recommended.

ITEM #	STYLE #	DESCRIPTION	LENGTH	OUTSIDE DIAMETER	WALL	WEIGHT PER CARTON	WEIGHT PER FOOT
275710		Round	20 ft.	3/4 in.	0.065 in.	72 lbs.	0.1644 lbs.
275711		Round	20 ft.	7/8 in.	0.065 in.	84 lbs.	0.2100 lbs.
275712		Round	20 ft.	7/8 in.	0.058 in.	70 lbs.	0.1750 lbs.
275713		Round	20 ft.	7/8 in.	0.095 in.	110 lbs.	0.2750 lbs.
275714		Round	24 ft.	7/8 in.	0.058 in.	70 lbs.	0.1750 lbs.
275715	6120	Round	20 ft.	3/4 in.	0.058 in.	167 lbs.	0.1546 lbs.
275718	6154	Square	24 ft.	1 in.	0.062 in.	178 lbs.	0.2650 lbs.
275719	6111-18	Round	24 ft.	7/8 in.	0.065 in.		0.2100 lbs.



No. 205381

BIMINI BOW FRAMES

Bow Bimini top kit (minus fabric). Comes in ready-to-assemble kit form. Packaged one boat set per box with hardware. Made with 7/8 in. outside diameter by 0.058 wall 6063, T832 hard drawn marine aluminum tubing with a brite anodized finish and joined together with inside sleeves. The radius of the bends is 6 in. inside diameter.

ITEM #	STYLE #	DESCRIPTION	MATERIAL
205381	4850D	2 Bow Frame	Aluminum
205382	4851D	3 Bow Frame	Aluminum

BOW SLATS – FIBERGLASS

These Trivantage® fiberglass bow slats have a slightly rounded edge, which reduces splinters and prevents damage to fabricated products like boat covers.

ITEM #	COLOR	LENGTH	STANDARD PACKAGE
266361	Natural	6 ft.	10
266362	Natural	6- 1/2 ft.	10
266363	Natural	7 ft.	10
266364	Natural	8 ft.	10
266365	Natural	10 ft.	10

Trivantage® is a registered trademark of Glen Raven, Inc.



No. 286199

BOAT TOP FITTINGS – CHROME-PLATED ZINC DIE-CAST – COAMING SIDE PLATE

For use on side of boat when regular hinge cannot be mounted on deck. Furnished with 1/4 inch – 28 x 3/4 inch stainless steel hinge bolt.

ITEM #	STYLE #	STANDARD PACKAGE
286199	898-1839	10



No. 282186

BOAT TOP FITTINGS – CHROME-PLATED ZINC DIE-CAST – INSERT EYE END

When inserted, flange of eye end is flush with outside of tubing. Must be secured by means of crimping tool or rivet. For use with Deck Mounting and Angle Hinges.

ITEM #	STYLE #	FOR	STANDARD PACKAGE
282185	1385	3/4 in. OD tube x 0.049 wall	10
282186	1836	7/8 in. OD tube x 0.049 wall	10

BOAT TOP FITTINGS – CHROME-PLATED ZINC DIE-CAST – SLIP FIT EYE END

With stainless steel set screw.



No. 282177



No. 282183



No. 282184

ITEM #	STYLE #	FOR	STANDARD PACKAGE
282177	824 HD	7/8 in. OD tube	10
282183	833A-1842	3/4 in. OD tube / 3/8 in. vinyl covered pipe	10
282184	824-1843	7/8 in. OD tube	10



No. 287890

BOAT TOP FITTINGS – CHROME-PLATED ZINC DIE-CAST – EYE STRAP

ITEM #	STYLE #	STANDARD PACKAGE
287890	8816	10



No. 284088

BOAT TOP FITTINGS – CHROME-PLATED ZINC DIE-CAST – ANGLE HINGE

10° angle, with stainless steel screw.

ITEM #	STYLE #	PROJECTION	STANDARD PACKAGE
284088	887-1841	1 in.	10



No. 284054

BOAT TOP FITTINGS – CHROME-PLATED ZINC DIE-CAST – DECK HINGE

ITEM #	STYLE #	DESCRIPTION	STANDARD PACKAGE
284054	N1846	Angle Deck Hinge – 5° with Quick Release	10



No. 284084



No. 284087

BOAT TOP FITTINGS – CHROME-PLATED ZINC DIE-CAST – DECK MOUNTING HINGE

Furnished with stainless steel machine screw.

ITEM #	STYLE #	PROJECTION	STANDARD PACKAGE
284084	878 HD	1-1/16 in.	10
284087	877	1-1/16 in.	10



No. 287687



No. 287691



No. 287881

BOAT TOP FITTINGS – CHROME-PLATED ZINC DIE-CAST – JAW SLIDE

Equipped with stainless steel set screw and machine screw.

ITEM #	STYLE #	FOR	STANDARD PACKAGE
287686	865	3/4 in. OD tube, 3/8 in. vinyl covered tube	10
287687	856-1838	7/8 in. OD tube	10
287691	856 HD	7/8 in. OD tube	10
287881	86004	7/8 in. OD tube	10



No. 287839

BOAT TOP FITTINGS – CHROME-PLATED ZINC DIE-CAST – BOAT COVER SOCKET

Ideal to keep boat covers from sagging. Use with Trivantage® Fiberglass Bow Slats to support boat cover. Two screw holes drilled for No. 8 screw.

ITEM #	STYLE #	SIZE	STANDARD PACKAGE
287839	840	1/2 in. height, 1-3/4 in. x 3/8 in. opening, 3-3/8 in. x 7/8 in. base	10
287840	740-CR180	3/8 in. height, 1-3/4 in. x 3/8 in. opening, 3-3/8 in. x 3/4 in. base	10

Trivantage® is a registered trademark of Glen Raven, Inc.



No. 249205

LEATHER PEARL SPLITS

Used for boat cover reinforcing. Approximately 6 to 8 square feet per hide; approximately 4 ounce per square feet. Sold in full hides only.

ITEM #

249205



No. 207608

BOAT TOP FITTINGS – NICKEL-PLATED BRASS – ADJUSTER BUCKLE

Single bar buckle to adjust strap.

ITEM #	STYLE #	STANDARD PACKAGE	WEBBING SIZE
--------	---------	------------------	--------------

207608	100	100	1 in.
--------	-----	-----	-------



No. 287872

BOAT TOP FITTINGS – NICKEL-PLATED BRASS – EYE STRAP

Style No. 2816 Eye Strap is for fastening No. 142-A Snap Hook to deck. Style No. 2916 Eye Strap is for fastening No. 249-0 Snap Hook to deck.

ITEM #	STYLE #	MATERIAL	STANDARD PACKAGE
--------	---------	----------	------------------

287870	2816	Nickel Plated Brass	10
287872	2916	Nickel Plated Brass	10



No. 266748



No. 266758

BOAT TOP FITTINGS – NICKEL-PLATED BRASS – SOLID EYE SNAP HOOK

ITEM #	STYLE #	LENGTH	STANDARD PACKAGE
--------	---------	--------	------------------

266748*	249-0	2-1/8 in.	10
266758	649	2 in. - 2-1/8 in.	10

*266748 - For use with 287872 Eye Strap.



No. 289639

BOAT TOP FITTINGS – NYLON – BIMINI TOP LADDER CLIP

ITEM #	STYLE #	COLOR	SIZE	STANDARD PACKAGE
--------	---------	-------	------	------------------

289598	4330W	White	7/8 in.	10
289599	4330	Black	1 in.	10
289639	4330	Black	7/8 in.	10
289640	4330W	White	1 in.	10



No. 289160

BOAT TOP FITTINGS – NYLON – FABRIC CLIP

ITEM #	FOR	STANDARD PACKAGE
--------	-----	------------------

289160	7/8 in. round x 1 in. round tubing	25
--------	------------------------------------	----



No. 289607

BOAT TOP FITTINGS – NYLON – RIGID SUPPORT CLIP

ITEM #	STYLE #	COLOR	SIZE	STANDARD PACKAGE
--------	---------	-------	------	------------------

289607	21463	Black	7/8 in.	10
--------	-------	-------	---------	----



No. 289608

BOAT TOP FITTINGS – NYLON – VADNEY CLIP

ITEM #	STYLE #	COLOR
--------	---------	-------

289608	1178120	Black
--------	---------	-------



No. 289201



No. 289202

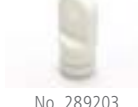

No. 289203



No. 289204

BOAT TOP FITTINGS – NYLON – EYE END

ITEM #	STYLE #	COLOR	FOR	STANDARD PACKAGE
--------	---------	-------	-----	------------------

289201	7402	White		10
289202	7416	White	3/4 in. OD tube	10
289203	7417	White		10
289204	7419	White	7/8 in. OD tube	10
289251	7402	Black		10
289252	7416	Black	3/4 in. OD tube	10
289253	7417	Black		10
289254	7419	Black	7/8 in. OD tube	10
289255	7419	Natural	7/8 in. OD tube	10



No. 289592

BOAT TOP FITTINGS – NYLON – EYE STRAP

ITEM #	STYLE #	COLOR	STANDARD PACKAGE
289591	7407	White	10
289592	7407	Black	10



No. 289089

BOAT TOP FITTINGS – NYLON – GASKET

Rubber gasket.

ITEM #	STYLE #	COLOR	STANDARD PACKAGE
289089	401-GB	Black	10



No. 289097

BOAT TOP FITTINGS – NYLON – CURVED SHIM

ITEM #	STYLE #	COLOR	STANDARD PACKAGE
289097	401-S-2.36B	Black	10
289098	401-S-2.36	Silver	10



No. 289302



No. 289430

BOAT TOP FITTINGS – NYLON – HINGE

ITEM #	STYLE #	DESCRIPTION	COLOR	SIZE	STANDARD PACKAGE
289302	7405	Large Deck Hinge	White		10
289351	7401	Small Deck Hinge	Black		10
289352	7405	Large Deck Hinge	Black		10
289354	7431	Deck Hinge/Slide Combination	Black		10
289430	7424P	Knurl Screw	Black	1/4 in. - 20 x 7/8 in.	10
289431	7424P	Knurl Screw	White	1/4 in. - 20 x 7/8 in.	10



No. 289453



No. 289454



No. 289458

BOAT TOP FITTINGS – NYLON – JAW SLIDE

ITEM #	STYLE #	COLOR	FOR	STANDARD PACKAGE
289451	7406	White	3/4 in. OD Tubing	10
289452	7418	White	7/8 in. OD Tubing	10
289453	7406	Black	3/4 in. OD Tubing	10
289454	7418B	Black	7/8 in. OD Tubing	10
289458	7515	Black	1 in. Square Tubing	10



No. 289362

BOAT TOP FITTINGS – NYLON – LASHING HOOK

ITEM #	STYLE #	COLOR	STANDARD PACKAGE
289360	7420	White	10
289362	7420	Black	10
289394	7460B	Black	10



No. 289460

BOAT TOP FITTINGS – NYLON – DOUBLE WING WINDSHIELD LATCH

ITEM #	STYLE #	COLOR	STANDARD PACKAGE
289460	7222B	Black	10

BOAT TOP FITTINGS – NYLON – SOCKET BOW

ITEM #	STYLE #	COLOR	STANDARD PACKAGE
289610	7434	Black	10



No. 289619

BOAT TOP FITTINGS – NYLON – SIDE CURTAIN SPACER

Designed to keep clear vinyl side curtains away from convertible top frames. Eliminates scratching and discoloration of vinyl curtains. Snaps over a 7/8 inch or 1 inch outside diameter tube. No tools required for assembly.

ITEM #	STYLE #	COLOR	FOR	STANDARD PACKAGE
289618	7628	White	7/8 in. OD tube	10
289619	7629	White	1 in. OD tube	10
289620		White	7/8 in. OD tube	10
289628		Gray	7/8 in. OD tube	10



No. 289088



No. 289091

BOAT TOP FITTINGS – NYLON – WEDGE

Converts 90° deck hinges to angle hinges. Install between deck hinge and deck.

ITEM #	STYLE #	DESCRIPTION	COLOR	STANDARD PACKAGE
289088	401-35B	Base Angle Polywedge – 10°	Black	10
289090	9530	Base Angle Wedge – 9°	Natural	10
289091	7530B	Base Angle Wedge – 9°	Black	10
289092	401-35N	Base Angle Polywedge – 10°	Natural	10



No. 289095



No. 289180



No. 289182



No. 289185



No. 289191



No. 289625

NYLON POLE FITTINGS

ITEM #	STYLE #	DESCRIPTION	COLOR	SIZE	STANDARD PACKAGE
289095	9518	Soft Outside End Cap	Black	7/8 in.	10
289180	7610B	Pole Tip	Black	7/8 in.	10
289181	7619	Vinyl Foot	Black	3/4 in.	10
289182	7620	Vinyl Foot	Black	7/8 in.	10
289183	7621	Pole End with Stainless Steel Cap	Black	3/4 in.	10
289185	7623	Jointer Section	Black		10
289190	PE20	Pole End Insert with Snap	Black	3/4 in.	10
289191	PE25	Pole End Insert with Snap	Black	7/8 in.	10
289625	7623	Tubing Adjustment Collar	Black	3/4 in. - 7/8 in.	10

NYLON POLE PADS

Non-slip base pole pad.

ITEM #	SIZE	STANDARD PACKAGE
274823	7/8 in.	10



No. 274819

TIP – RUBBER

Eliminates damage or wear on fabric end curtains of patio awning where a Tie-Down Bar is used. Slips over ends of pipe used on roller curtains, to prevent end of pipe from chafing side of house. Can also be used on mooring poles to prevent marring boat floor.

ITEM #	STYLE #	DESCRIPTION	COLOR	FOR	STANDARD PACKAGE
274815	18	Tip	White	3/4 in. tubing	10
274816	17	Tip	White	5/8 in. tubing, 3/8 in. pipe	10
274817	17	Tip	Black	5/8 in. tubing, 3/8 in. pipe	10
274818	19	Tip	White	7/8 in. tubing, 1/2 in. pipe	10
274819	19	Tip	Black	7/8 in. tubing, 1/2 in. pipe	10
476095	18	Tip with Stud	White	3/4 in. tubing	10

SLIDE TRACK – NYLON – TRACK

ITEM #	STYLE #	LENGTH
266343	6410 TM-5	14 ft.



No. 289551

SLIDE TRACK – NYLON – SLIDES

ITEM #	STYLE #	DESCRIPTION	COLOR
289505	7408	Slide for Deck Hinge	Natural
289551	7408	Slide for Deck Hinge	Black
289553	7430	Side Mount Slide	Black



No. 289342

SLIDE TRACK – NYLON – HINGE

ITEM #	STYLE #	DESCRIPTION	COLOR	SIZE	STANDARD PACKAGE
289342	7443	Concave Hinge Rail	Black	7/8 in.	10



No. 289402

SLIDE TRACK – NYLON – MOUNTING PLATE

ITEM #	STYLE #	DESCRIPTION	COLOR	STANDARD PACKAGE
289402	7415	Slide Mount Plate – 2-Hole	Black	10



No. 284224

SLIDE TRACK – NYLON – SLIDE CAP

ITEM #	STYLE #	DESCRIPTION	COLOR	STANDARD PACKAGE
284224		Slide Track End Cap	White	10
289102	7404	Slide Cap Channel Trim End Cap	Black	10
289153	7429	Slide Cap Channel Trim End Insert	Black	10



No. 289102



No. 289371

SLIDE TRACK – NYLON – SLIDE LOCK

ITEM #	STYLE #	DESCRIPTION	COLOR	STANDARD PACKAGE
289371	7432	Slide Lock	Black	10



No. 154700

POLE – MOORING – ALUMINUM “THUMB SCREW”

Designed especially for boat mooring covers, the 730 Mooring Pole adjusts to 70 in. overall and collapsed measures 40-5/8 inch. Has 2-1/2 inch long swaged tip designed for No. 3 Grommet or larger. Top section is 3/4 inch O.D. x .049 wall and bottom section is 7/8 inch O.D. x .042 wall, mill finish, drawn 6063T832 aluminum tubing. Comes with crutch tip bottom to prevent marring of boat floor.

ITEM #	STYLE #	MAXIMUM EXTENSION	STANDARD PACKAGE
154700	730	5 ft. 10 in.	10



No. 207620

BOAT TOP FITTINGS – STAINLESS STEEL TYPE 304 – ADJUSTER BUCKLE

ITEM #	STYLE #	DESCRIPTION	STANDARD PACKAGE	WEBBING SIZE
207620	300	Adjuster Buckle Single Bar	10	1 in.



No. 260450

BOAT TOP FITTINGS – STAINLESS STEEL TYPE 304 – DEE RING

ITEM #	STYLE #	DESCRIPTION	SIZE	STANDARD PACKAGE
260450	127-20-70816	Welded	1 in.	10
260456		Welded	1-1/2 in.	10
284235	SS-563-1		1 in.	10

POLE – SUPPORT – ALUMINUM EXTENSION

A medium range, multi-purpose support pole with interchangeable end components. Simply turn the pole extension around for a choice of either plastic injection molded end with snap stud or a molded swaged tip.

ITEM #	STYLE #	EXTENSION BAR THREADED	SIZE	STANDARD PACKAGE
205452	X47A-2		47 in.	10
205457	X59A-2TIP		59 in.	10
205459	X70A-2TIP		70 in.	10

BOAT TOP FITTINGS – ALUMINUM – POP RIVET

ITEM #	SIZE	STANDARD PACKAGE
248222	1/4 in. x 0.481 in.	100



No. 205454

POLE – MOORING – ALUMINUM EXTENSION

A medium range, multi-purpose support pole with interchangeable end components. Simply turn the pole extension around for a choice of either plastic injection molded end with snap stud or a molded swaged tip.

ITEM #	STYLE #	DESCRIPTION	EXTENSION BAR THREADED	STANDARD PACKAGE
205453	4848		48 in. to 96 in.	10
205454	3636	Black Crutch Tip	40 in. to 70 in.	10

BOAT TOP FITTINGS – STAINLESS STEEL TYPE 304 – PULL PIN



No. 284074

Item no. 284704 – Pull pin with 3/16 inch diameter pin, 1 inch grip and 1 inch ring handle.



No. 284075

Item no. 284075 – Pull pin with 1/4 inch diameter pin, 3/4 inch grip, 1 inch ring handle, and 6 inch nylon-coated, stainless steel lanyard with 1-1/4 inch stainless steel tab.

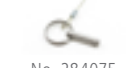

No. 284077

Item no. 284077 – Pull pin with 1/4 inch diameter flip type pin and 1-1/8 inch ring; pin includes stainless steel wire outer spring guard for flip.



No. 284097

Item no. 284097 – Pull pin with 1/4 inch diameter flip type pin, 1-1/8 inch ring and 6 inch plastic coated, stainless steel lanyard with 1-1/4 inch stainless steel tab; pin includes stainless steel wire outer spring guard for flip.

ITEM #	STYLE #	DESCRIPTION	STANDARD PACKAGE
284074	C3-10R-303	Pull Pin	10
284075	74-7-303	Pull Pin with Lanyard/Tab	10
284077	1815-1	Pull Pin – Flip Type	10
284097		Pull Pin with Lanyard/Tab – Flip Type	10

BOAT TOP FITTINGS – STAINLESS STEEL TYPE 304 – LIFT RING



No. 284060

ITEM #	STYLE #	DESCRIPTION	STANDARD PACKAGE
284060	F16-1812	Flush Mount Lift Ring	10

BOAT TOP FITTINGS – STAINLESS STEEL TYPE 304 – MACHINE BOLT



No. 206050

ITEM #	DESCRIPTION	STANDARD PACKAGE	THREADED FOR SIZE
206050	Machine Bolt for #388 Deck Plate	10	5/16 - 18

BOAT TOP FITTINGS – STAINLESS STEEL TYPE 304 – HINGE/SET SCREW



No. 263914

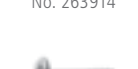

No. 263915

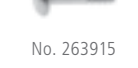

No. 263917



No. 263918

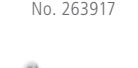

No. 263919

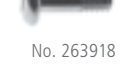

No. 263920



No. 263930

ITEM #	STYLE #	DESCRIPTION	SIZE	STANDARD PACKAGE	THREADED FOR SIZE
263914		Machine Screw for #356/357 Jaw Slides		10	1/4 - 20
263915		Machine Screw for #387 Angle Hinge		10	1/4 - 20
263917		Machine Screw for #378/386 Hinge		10	1/4 - 20
263918		Machine Screw for #398 Side Deck Plate		10	1/4 - 20
263930		Cup Point Set Screw	3/16 in.	10	1/4 - 28
284282	88338	Cone Point Allen Drive Set Screw	3/16 in.	100	1/4 - 28

BOAT TOP FITTINGS – STAINLESS STEEL TYPE 304 – SNAP HOOK



No. 266752

ITEM #	STYLE #	DESCRIPTION	MATERIAL	LENGTH	STANDARD PACKAGE	WEBBING SIZE
266683	142-A	Steel Wire Snap	Stainless Steel	2-1/8 in.	100	1 in.
266752	142-A	Steel Wire Snap	Stainless Steel	2-1/8 in.	100	2 in.

BOAT TOP FITTINGS – STAINLESS STEEL TYPE 316 – EYE END



No. 282132



No. 282173



No. 282133



No. 284257



No. 282172

ITEM #	STYLE #	DESCRIPTION	FOR	STANDARD PACKAGE
282132	324-88313	Eye End	7/8 in. OD tube	10
282133	338-88314	Eye End	1 in. OD tube	10
282172	324	Eye End	7/8 in. OD tube	10
282173	338	Eye End	1 in. OD tube	10
284257	88328	Eye End with Double Set Screw	1-1/4 in. OD tube	10

BOAT TOP FITTINGS – STAINLESS STEEL TYPE 316 – ADJUSTABLE EYE END



No. 284264

ITEM #	STYLE #	DESCRIPTION	FOR	STANDARD PACKAGE
284264	9114660	Adjustable Eye End	1 in. OD tube	1 Pair

BOAT TOP FITTINGS – STAINLESS STEEL TYPE 316 – BALL EYE END



No. 282210



No. 282214



No. 282211

ITEM #	STYLE #	DESCRIPTION	FOR	STANDARD PACKAGE
282209	F11-0177A	Ball Eye End For Pop Rivet	7/8 in. OD tube	10
282210	F11-0177S	Ball Eye End For Set Screw	7/8 in. OD tube	10
282211	F11-0180S	Ball Eye End – 90°	7/8 in. OD tube	10
282214	F12-0181S	Ball Eye End	1 in. OD tube	10

BOAT TOP FITTINGS – STAINLESS STEEL TYPE 316 – COUNTER BORE EYE END



No. 282171



No. 282175

ITEM #	STYLE #	DESCRIPTION	FOR	STANDARD PACKAGE
282171	324	Counter Bore Eye End without Set Screw	7/8 in. OD tube	10
282175	333	Counter Bore Eye End without Set Screw	3/4 in. OD tube	10

BOAT TOP FITTINGS – STAINLESS STEEL TYPE 316 – HUMPBACK EYE END



ITEM #	STYLE #	DESCRIPTION	FOR	STANDARD PACKAGE
282139	88396	Humpback Eye End with Double Set Screw	7/8 in. OD tube	10
282140	88397	Humpback Eye End with Double Set Screw	1 in. OD tube	10
282176	324	Humpback Eye End	7/8 in. OD tube	10
282179	338	Humpback Eye End	1 in. OD tube	10
282187	8208	Humpback Eye End with 2 Double set Screws	1-1/4 in. OD tube	10

BOAT TOP FITTINGS – STAINLESS STEEL TYPE 316 – INSERT EYE END

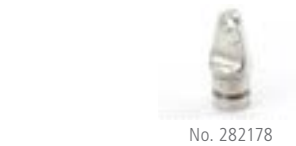

ITEM #	STYLE #	DESCRIPTION	FOR	STANDARD PACKAGE
282178	324I	Eye End Insert	7/8 in. OD tube	10
282180	338I	Eye End Insert	1 in. OD tube	10

BOAT TOP FITTINGS – STAINLESS STEEL TYPE 316 – EYE STRAP



ITEM #	STYLE #	DESCRIPTION	DRILLED FOR	STANDARD PACKAGE
284216	88542	Formed Eye Strap	#8 screw	10
284276	88545	Eye Strap		10
287874	3716	Heavy Duty Eye Strap		10
287875	3816	Eye Strap		10

BOAT TOP FITTINGS – STAINLESS STEEL TYPE 316 – GRAB HANDLE



ITEM #	STYLE #	DESCRIPTION	STANDARD PACKAGE
284262	9114665	Bimini/Dodger Adjustable Grab Handle	2

BOAT TOP FITTINGS – STAINLESS STEEL TYPE 316 – ANGLE HINGE



ITEM #	STYLE #	DESCRIPTION	DRILLED FOR	PANHEAD SCREW	PROJECTION	SIZE	STANDARD PACKAGE
284071	387	Angle Hinge – 10°	#10 screw	1/4 - 20	1 in.	7/8 in. x 2 in.	10
284073*	387QR	Angle Hinge without Pin – 10°	#10 screw	1/4 - 20	1 in.	7/8 in. x 2 in.	10
284076	886	Universal Deck Hinge – 90°	1/4 in. screws	M6 x 1	7/8 in.	1 in. x 2-1/8 in.	10
284078	886A	Universal Deck Hinge – 45°	1/4 in. screws	M6 x 1	1 in.	1 in. x 2-1/8 in.	10
284207	230	Angle Hinge with Screw	#10 screw				10
284208	233	Angle Hinge without Screw	#10 screw				10

*284073 - 1/4 inch drilled hole (no pin).

BOAT TOP FITTINGS – STAINLESS STEEL TYPE 316 – CONCAVE HINGE



No. 284086



No. 284210



No. 284209

ITEM #	STYLE #	DESCRIPTION	DRILLED FOR	PROJECTION	SIZE	STANDARD PACKAGE
284086	386R	Concave Hinge	#10 screw	1-1/4 in.	3/4 in. x 2-7/16 in.	10
284209	88321	Concave Hinge with 1/4 in. Bolt	#10 screw	1-3/8 in.	7/8 in. x 2 in.	10
284210	88321N	Concave Hinge without Pin	#10 screw	1-3/8 in.	7/8 in. x 2 in.	10

BOAT TOP FITTINGS – STAINLESS STEEL TYPE 316 – SOCKET



No. 284120



No. 284124



No. 284123

ITEM #	STYLE #	DESCRIPTION	STANDARD PACKAGE
284120	F13-0241/244BN	Deck Hinge Socket with Lanyard	10
284123	F13-0301/244BN	Hinge Socket with Lanyard	10
284124	F13-0242/244BN	Concave Hinge Socket with Lanyard	10
284132	F13-1095P	Socket Hinge with D-Ring – Port	10
284133	F13-1095S	Socket Hinge with D-Ring – Starboard	10

BOAT TOP FITTINGS – STAINLESS STEEL TYPE 316 – DECK HINGE



No. 282134



No. 284206



No. 284059



No. 284102



No. 284082



No. 284070



No. 284083

ITEM #	STYLE #	DESCRIPTION	DRILLED FOR	PANHEAD SCREW	PROJECTION	SIZE	STANDARD PACKAGE
282134	88320N	Deck Hinge without Pin – 90°	#10 screw			3/4 in. x 2 in.	10
284040	G615	Universal Deck Hinge					10
284059		Heavy Duty Adjustable Deck Hinge – 90°			1-1/2 in.		10
284070	378	Straight Deck Hinge	#10 screw	1/4 - 20	1-1/8 in.	7/8 in. x 2 in.	10
284082*	378QR	Deck Hinge without Pin	#10 screw		1-1/8 in.	7/8 in. x 2 in.	10
284083	401	Bimini Quick Release Deck Hinge	#10 screw		1 in.	1-3/16 in. x 3-1/2 in.	10
284102	415	Bimini Quick Release Deck Hinge					10
284130	F13-1085P	Deck Hinge with D-Ring Port					10
284131	F13-1085S	Deck Hinge with D-Ring Starboard					10
284206	88320	Deck Hinge – 90°					10
284259	88320-3	High Profile Deck Hinge			1-1/4 in.		10

*284082 - 1/4 inch drilled hole (no pin).

BOAT TOP FITTINGS – STAINLESS STEEL TYPE 316 – POST



No. 284091

ITEM #	STYLE #	DESCRIPTION	SIZE	STANDARD PACKAGE
284091	401-P-07	Bimini Quick Release Deck Hinge Post	5/8 in.	10
284109	401-P-07	Bimini Quick Release Deck Hinge Post	1/2 in.	10

BOAT TOP FITTINGS – STAINLESS STEEL TYPE 316 – LOCKING RAIL HINGE



No. 284265

ITEM #	STYLE #	DESCRIPTION	FOR	STANDARD PACKAGE
284265	9027204	Locking Rail Hinge with Quick Release Pin	7/8 in. OD tube	10
284270	9027202	Locking Rail Hinge with Quick Release Pin	1 in. OD tube	10

BOAT TOP FITTINGS – STAINLESS STEEL TYPE 316 – SIDE DECK PLATE HINGE



No. 286170



No. 286173

ITEM #	STYLE #	DESCRIPTION	BOLT SIZE	DRILLED FOR	SIZE	STANDARD PACKAGE
286170	398	Side Deck Plate – 2-Hole	1/4 in. - 20	#10 screw	7/8 in. x 2 in.	10
286172	388	Side Deck Plate – 4-Hole	1/4 in. - 20 Phillips			100
286173	388	Side Deck Plate – 4-Hole	5/16 in. Hex			100

BOAT TOP FITTINGS – STAINLESS STEEL TYPE 316 – SIDE MOUNT HINGE



No. 289325

ITEM #	DESCRIPTION	FOR	STANDARD PACKAGE
289323	Split Side Mount Hinge	1-1/4 in. OD tube	10
289324	Sliding Side Mount Hinge	1-1/4 in. OD tube	10
289325	Sliding Side Mount Hinge	7/8 in. OD tube	10
289326	Sliding Side Mount Hinge	1 in. OD tube	10
289328	Split Side Mount Hinge	1 in. OD tube	12

BOAT TOP FITTINGS – STAINLESS STEEL TYPE 316 – LASHING HOOK



No. 287876

With two 3/16 inch holes.

ITEM #	STYLE #	DESCRIPTION	SIZE	STANDARD PACKAGE
287876	89010	Lashing Hook	1 in. x 1-1/4 in.	10

BOAT TOP FITTINGS – STAINLESS STEEL TYPE 316 – DOUBLE-SIDED JAW SLIDE



No. 287655

ITEM #	STYLE #	DESCRIPTION	FOR	STANDARD PACKAGE
287648	G697S	Double Side Jaw Slide with Swivel Hinge	1 in. OD tube	10
287655	88317-2	Double Sided Jaw Slide	1 in. OD tube	10

BOAT TOP FITTINGS – STAINLESS STEEL TYPE 316 – HEAVY-DUTY JAW SLIDE



No. 284258

ITEM #	STYLE #	DESCRIPTION	FOR	STANDARD PACKAGE
284258	88329	Heavy Duty Jaw Slide with 2 Set Screws	1-1/4 in. OD tube	10



No. 284268 No. 287638



No. 284269 No. 287639

BOAT TOP FITTINGS – STAINLESS STEEL TYPE 316 – HINGED JAW SLIDE

ITEM #	STYLE #	DESCRIPTION	FOR	STANDARD PACKAGE
284267	8731442	Hinged Jaw Slide with Allen Set Screw	7/8 in. OD tube	10
284268	8731443	Hinged Jaw Slide with Allen Set Screw	1 in. OD tube	10
284269	8731447	Hinged Jaw Slide with Allen Set Screw	1-1/4 in. OD tube	10
287638	35081	Hinged Jaw Slide	7/8 in. OD tube	10
287639	35082	Hinged Jaw Slide	1 in. OD tube	10



No. 226947

BOAT TOP FITTINGS – STAINLESS STEEL TYPE 316 – RAIL

ITEM #	DESCRIPTION	FOR	STANDARD PACKAGE
226947	Locking Hinged Jaw Slide	1 in. OD tube	10
226948	Locking Hinged Jaw Slide	1-1/4" OD tube	10



No. 282137



No. 287657



No. 282138



No. 287659

BOAT TOP FITTINGS – STAINLESS STEEL TYPE 316 – HUMPBACK JAW SLIDE

ITEM #	STYLE #	DESCRIPTION	FOR	STANDARD PACKAGE
282137	88398	Humpback Jaw Slide with 2 Set Screws	7/8 in. OD tube	10
282138	88399	Humpback Jaw Slide with 2 Set Screws	1 in. OD tube	10
287657	356	Humpback Jaw Slide	7/8 in. OD tube	10
287659	368	Humpback Jaw Slide	1 in. OD tube	10



No. 282135



No. 287652



No. 282136



No. 287653



No. 287651

BOAT TOP FITTINGS – STAINLESS STEEL TYPE 316 – JAW SLIDE

ITEM #	STYLE #	DESCRIPTION	FOR	PANHEAD SCREW	STANDARD PACKAGE
282135	356-88316	Jaw Slide without Set Screw	7/8 in. OD tube		10
282136	356-88317	Jaw Slide without Set Screw	1 in. OD tube		10
287651	356	Counter Bore Jaw Slide without Set Screw	7/8 in. OD tube		10
287652	356	Jaw Slide with 1/4-28 Set Screw	7/8 in. OD tube	1/4 - 20	10
287653	368	Jaw Slide with 1/4-28 Set Screw	1 in. OD tube	1/4 - 20	10



No. 284255

**BOAT TOP FITTINGS – STAINLESS STEEL
TYPE 316 – JAW SLIDE FOR POP RIVET**

ITEM #	STYLE #	DESCRIPTION	FOR	STANDARD PACKAGE
284255	F11-1001	Jaw Slide Socket For Pop Rivet	7/8 in. OD tube	10



No. 287635

**BOAT TOP FITTINGS – STAINLESS STEEL TYPE
316 – SOCKET JAW SLIDE**

ITEM #	STYLE #	DESCRIPTION	FOR	STANDARD PACKAGE
287635	F11-1001AS	Jaw Slide Socket with Set Screw	7/8 in. OD tube	10



No. 287636

287636	F12-0300S	Jaw Slide Socket with Set Screw	1 in. OD tube	10
--------	-----------	---------------------------------------	---------------	----



No. 284215

**BOAT TOP FITTINGS – STAINLESS STEEL
TYPE 316 – ADJUSTER BUCKLE**

ITEM #	STYLE #	DESCRIPTION	FOR	STANDARD PACKAGE
284215	9114706	Web Adjuster Buckle with Recessed Base	1 in. OD tube	10



No. 284126

**BOAT TOP FITTINGS – STAINLESS STEEL
TYPE 316 – PULL PIN**

ITEM #	STYLE #	DESCRIPTION	STANDARD PACKAGE
284126	F13-0244BN	Pull Pin with Pull Knob and Lanyard	10



No. 284217



No. 284218



No. 284220



No. 284221

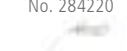

No. 284221



No. 284221



No. 284203

**BOAT TOP FITTINGS – STAINLESS STEEL
TYPE 316 – QUICK RELEASE PIN**

ITEM #	STYLE #	DESCRIPTION	STANDARD PACKAGE
284217	88546	Quick Release Pin	10
284218	88547	Quick Release Pin with Tab and Cable	10
284220	88551	Quick Release Pin with Long DCAM-S Ring	10
284221	88548	Quick Release Pin with Long DCAM-S Cable	10

**BOAT TOP FITTINGS – STAINLESS STEEL
TYPE 316 – PUSH BUTTON**

ITEM #	STYLE #	DESCRIPTION	STANDARD PACKAGE
284203	89008	Push Button	10



No. 226965

BOAT TOP FITTINGS – STAINLESS STEEL TYPE 316 – SNAP HOOK

ITEM #	STYLE #	DESCRIPTION	FOR	MATERIAL	LENGTH	STANDARD PACKAGE	WEBBING SIZE
226965		Fast Eye Heavy Duty Snap Hook	1 in. OD tube			10	
266750	142-A			Stainless Steel	2-1/8 in.	10	1 in.
284211	249-SS #0	Snap	3/8 in. OD tube			10	
284281	8928263	Heavy Duty Snap Hook	1 in. OD tube			10	



No. 284211



No. 284281



No. 226940

BOAT TOP FITTINGS – STAINLESS STEEL TYPE 316 – SIDE MOUNT WITH CONCAVE BASE

ITEM #	DESCRIPTION	STANDARD PACKAGE
226940	Side Mount – 90°	10
226941	Side Mount – 75°	10



No. 226929

BOAT TOP FITTINGS – STAINLESS STEEL TYPE 316 – PLUG

ITEM #	STYLE #	DESCRIPTION	FOR	STANDARD PACKAGE
226929	88303	Bullet End Plug	7/8 in. OD tube	10



No. 226921

BOAT TOP FITTINGS – STAINLESS STEEL TYPE 316 – HINGED TEE

ITEM #	DESCRIPTION	FOR	STANDARD PACKAGE
226921	Hinged Slip Tee – 90°	7/8 in. OD tube	10



No. 208340

BOAT TOP FITTINGS – STAINLESS STEEL – PUSH BUTTON

ITEM #	STYLE #	MATERIAL	SIZE	STANDARD PACKAGE
208340	II-132	Stainless Steel	1/4 in.	10



No. 255216

BOAT TOP FITTINGS – STAINLESS STEEL – BOLSTER CLIP

ITEM #	STYLE #	MATERIAL	SIZE
255216	F16-0094	Stainless Steel	3 in.



No. 282216

BOAT TOP FITTINGS – STAINLESS STEEL TYPE 316 – ELBOW EYE END

ITEM #	STYLE #	DESCRIPTION	FOR	STANDARD PACKAGE
282216	88310	Elbow – 90°	1 in. OD tube	10



No. 226920

BOAT TOP FITTINGS – STAINLESS STEEL TYPE 316 – SLIP TEE

ITEM #	DESCRIPTION	FOR	STANDARD PACKAGE
226920	Slip Tee – 90°	7/8 in. OD tube	10
226922	Slip Tee – 90°	1 in. OD tube	10



No. 226922

MARINE TUBING – STAINLESS STEEL TYPE 304

For convertible boat tops and boat railings. Available from 7/8 inch to 1-1/4 inch O.D. with 16 and 18 gauge wall thicknesses. This tubing is tig welded, polished, buffed and paper sleeved. Sold in full lengths only.

ITEM #	GAUGE	LENGTH	OUTSIDE DIAMETER	PUT UP	WEIGHT PER FOOT
275759	16	24 ft.	7/8 in.	480 ft.	0.5591 lbs.
275761	18	20 ft.	7/8 in.	400 ft.	0.4593 lbs.
275763	18	24 ft.	7/8 in.	480 ft.	0.4593 lbs.
275765	16	24 ft.	1 in.	360 ft.	0.6452 lbs.
275768	16	20 ft.	1 in.	300 ft.	0.6452 lbs.
275769	16	24 ft.	1-1/4 in.	216 ft.	0.8174 lbs.
275779	18	24 ft.	1 in.	360 ft.	0.5290 lbs.
275781	16	20 ft.	1-1/4 in.	180 ft.	0.8174 lbs.

MARINE TUBING – STAINLESS STEEL TYPE 316

ITEM #	GAUGE	LENGTH	OUTSIDE DIAMETER	PUT UP	WEIGHT PER FOOT
275790	16	20 ft.	1 in.	300 ft.	0.6261 lbs.
275791	16	24 ft.	1 in.	360 ft.	0.6261 lbs.
275797	16	24 ft.	1-1/4 in.	216 ft.	0.8174 lbs.

MOLDING – PVC



No. 251028

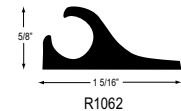

R1062

No. 251051

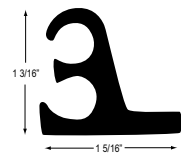

R1234

No. 251058

This rigid PVC molding is UV resistant, non-corrosive, non-rusting and can be used in or on salt water. Can be shaped very easily.

Will cold crack under extreme cold conditions.

ITEM #	STYLE #	DESCRIPTION	COLOR	DEGREE OF CHANNEL	LENGTH	WEIGHT PER FOOT
251026	1445		White	90 degrees	18 ft.	0.15 lbs.
251028	333		White	90 degrees	8 ft.	0.15 lbs.
251051	R1062		White		8 ft.	0.185 lbs.
251052	R1062		White		14 ft.	0.185 lbs.
251057	R1338	Double Ceiling Molding	White		8 ft.	0.2451 lbs.
251058	R1234	Double Wall Molding	White		8 ft.	0.325 lbs.



No. 578062

TRACK – EZ 100

Concave back, single track designed for use on perimeter pipe and more. Virtually disappears when enclosure is mounted. Available in top or bottom mount.

ITEM #	DESCRIPTION	COLOR	LENGTH
578062	Top Channel Concave	White	8 ft.
578064	Top Channel Concave	White	16 ft.
578065	Bottom Channel Concave	White	8 ft.
578068	Bottom Channel Concave	White	16 ft.



No. 578072

TRACK – EZ 104

Windshield cap track mounts on top edge of windshield. Easily forms to windshield shape.

ITEM #	COLOR	LENGTH
578072	White	8 ft.
578073	White	16 ft.

TRACK – COSTA TRACK®

Costa Track is a center mount track with a heavy-duty PVC profile that maximizes load capability for large covers, bimini and track-to-track enclosures. It is pre-drilled every four inches, and can be heat-formed to most radiuses. Its large channel opening allows use of stainless steel #6 oval head screws for more secure attachment. The deep screw trough base design allows for use of 8.5mm Keder with sufficient clearance of screw heads.

Costa Track is designed with a pocketed underside to accommodate Double-Faced Foam Pressure Sensitive Tape, which is used to set and seal the track to the mounting surface before being secured with the screws.

ITEM #	DESCRIPTION	COLOR	LENGTH	TYPE
578060	UVR Heavy Duty Vinyl	White	8 ft.	Flat
578061	UVR Heavy Duty Vinyl	White	16 ft.	Flat
578063	UVR Heavy Duty Vinyl	Off-White	16 ft.	Flat
578066	UVR Heavy Duty Vinyl	Off-White	16 ft.	Contoured
578067	UVR Heavy Duty Vinyl	White	16 ft.	Contoured

Costa Track® is a registered trademark of Costa Marine Canvas and Enclosures.



TRACK – THREE CHANNEL – PVC

This white PVC Three Channel Track is designed to extend double track capabilities to locations where fasteners are not available, or when track cannot be mounted to a boat, such as the crown on a hardtop, and cross sections of fabric or stainless steel rods. This track can be used with Trivantage® 8.5 mm Keder.

ITEM #	STYLE #	COLOR	LENGTH	PUT UP
578069	0773	White	12 ft.	12 ft.

Trivantage® is a registered trademark of Glen Raven, Inc.

TRACK – FLEX-A-RAIL

Flex-A-Rail provides quick and easy installation of boat windshields, tops, covers and curtains. It can also be used to mount awnings and truck covers.

A PVC extrusion, Flex-A-Rail is non-corrosive and can be run around tight corners without the use of crimping tools. Only small amounts of heat are needed to bend or straighten. Pre-drill holes just slightly larger than the shank of the screw. Holes should be 2 inches to 2-1/2 inches apart for tight radiuses, and 4 inches to 8 inches apart depending upon the configuration of the mounting surface.

ITEM #	STYLE #	DESCRIPTION	COLOR	LENGTH	STANDARD PACKAGE
578017	90-2-W	UVR Vinyl	White	90 in.	100
578018	90-2-B	UVR	Black	90 in.	100
578019	180-2-W	UVR Vinyl	White	180 in.	50



TRACK – HEADLINER

Headliner track is an efficient and cost effective way to install or replace headliners. With Headliner Track, there is no need for staplers or trim strips, and fabricators no longer need to work in enclosed spaces using toxic adhesives and heavy foam backed fabrics.

Headliner Track also makes it possible to replace damaged headliners or work on parts of the boat which were previously not accessible without damaging or rebuilding the entire headliner. Headliner Track allows you to simply pull the fabric out of the track and put it back when the work is done.

Headliner Track is available in two profiles. The Perimeter track is used for the outside edge of a cabin ceiling and the Mid-Wall track is used as an intermediate attachment of the headliner fabric's seams and centerlines. Attached with screws, Headliner Track can be easily mitered for clean corners or slotted for gradual bends and curves.

ITEM #	DESCRIPTION	LENGTH
578070	Perimeter Track	18 ft.
578071	Mid-Wall Track	18 ft.



No. 275454



No. 275455

TRACK – HEADLINER – TOOLS

Four custom Headliner track tools make fabric installation a snap. Each tool is lightweight and ergonomically designed with textured, non-slip surfaces. Tools include a 45-degree angle short run tool for tight spaces at close angles; a curved edge tool and straight edge tool for straight runs of short distance; and a nine-inch pizza cutter for long runs of either the Perimeter or Mid-Wall Track.

ITEM #	DESCRIPTION
275454	Pizza Cutter Tool
275455	Straight Edge Tool
275456	Curved Edge Tool
275457	Bend Tool – 45°



No. 265450



No. 265452

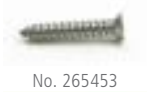

No. 265453

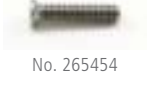

No. 265454

TRACK – TRIM SCREWS

For use with PVC and aluminum track.

ITEM #	DESCRIPTION	MATERIAL	SIZE	STANDARD PACKAGE
265450	Phillips Head Trim Screw	Stainless Steel	#6 x 3/4" x #4 Pan Head	1000
265452*	Hex Driver for Trim Screw			1
265453	Hex Head Trim Screw	Stainless Steel		100
265454	Phillips Head Trim Screw	Stainless Steel	#6 x 5/8" x #4	100

*265452 - For use with Hex Head Trim Screw (Item No. 265453).



No. 277541

VENT – BOAT VENT II®

A plastic cover support and venting device for use with 3/4 inch or 7/8 inch mooring poles. Designed to distribute a greater volume of exhaust air while closing the top-to-bottom gap that keeps rain out. Suitable for all types of fabric. Unique design eliminates the need for screws, saving time.

ITEM #	COLOR	STANDARD PACKAGE
277541	Black	1

Boat Vent II® is a registered trademark of William Gridley.



No. 277540

VENT – BOAT VENT II® CIRCLE CUTTER

Convenient circle cutter allows a hole to be cut in a matter of seconds, for quick and easy installation of Boat Vent II device into fabric.

ITEM #	DESCRIPTION	STANDARD PACKAGE
277540	Boat Vent II Circle Cutter	1
277542	Boat Vent II Circle Cutter Replacement Blade	1

Boat Vent II® is a registered trademark of William Gridley.



No. 277525

VENT-SO-PORT

High impact, black molded ABS plastic cap with UV stabilizers, slips onto an aluminum mooring pole. The large dome allows air to circulate freely, reducing condensation and mildew. Cap replaces the mooring pole grommet and attaches to the boat cover with four stainless steel screws included. Ideal for use on non-breathable cover fabrics such as Aqualon®. Can be used with our No. P42 Mooring Pole and No. 730 Mooring Pole by reversing the top section into the bottom section.

ITEM #	COLOR	MATERIAL	STANDARD PACKAGE
277525	Black	ABS Molded Plastic	1

Aqualon® is a registered trademark of Glen Raven, Inc.



No. 277550

VENT-SOL-AIR™

Vent-Sol-Air uses a solar-powered fan to circulate air under tented boat covers, which fights mold and mildew, and maintains the appearance of a boat's interior.

Vent-Sol-Air mounts to the pole of tented boat covers and installs in minutes. Its sealed, water-resistant design is constructed of tough-plastic for marine-grade durability. Vent-Sol-Air taps the natural power of the sun without using batteries or power cords.

ITEM #	STANDARD PACKAGE
277550	1



No. 277501

VENTILATOR – AIRLETTE®

Installs in seconds without the aid of hardware or adhesives, by “snapping” into place with an assured water-tight seal. The Airlette Ventilator automatically self-adjusts to fit any material up to 1/8 inch thick. Its hood rotates 360° and can be detached for easy storage.

ITEM #	STYLE #	COLOR	STANDARD PACKAGE
277501	BSA-2	White	1

Airlette® is a registered trademark of Airlette Manufacturing Corporation.



No. 277610

VENTILATOR – VENT-AIRE®

Vent-Aire Vents prevent dry-rot, condensation, mildew and rust. Made of tough, pliable plastic, which snaps back without damage after being bent, folded or flattened. Special hood design ensures that vent will remain open regardless of how cover material is folded.



No. 277630



No. 277660

ITEM #	STYLE #	COLOR	SIZE	STANDARD PACKAGE
277610	61	Natural	Large	1
277630	62	Natural	Medium	1
277660	63	Natural	Small	1
277662	63	Black	Small	1

Vent-Aire® is a registered trademark of Kaybob Products Co.



No. 274811

HANGTYTE BOAT COVER SYSTEM

An alternative to pole systems, HANGTYTE is a boat cover suspension device that works with all covers. Simple setup. Easy operation.

ITEM #	STYLE #
274811	60901-0000

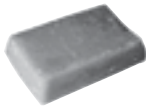

No. 279201

BEESWAX

Supplied in approximately one pound cakes.

ITEM #	WEIGHT
279201	1 lbs.



No. 213110

CLAMP – STEEL CLOTH

Oil tempered spring. Style No. 3202HT has a full length of 6 inches and opens 2 inches.

ITEM #	STYLE #	LENGTH	OPENS TO	STANDARD PACKAGE
213110	3202HT	6 in.	2 in.	1

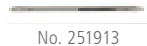

No. 251913

NEEDLE – SAIL

ITEM #	STYLE #	FINISH	LENGTH	MATERIAL	STANDARD PACKAGE	TYPE
251706	501	Nickel Plated	6 in.	Steel	12	Curved
251913	13	Nickel Plated	3 in.	Steel	25	Standard
251916	16	Nickel Plated	2-3/8 in.	Steel	25	Standard



No. 254501

SAILMAKER'S PALM

Riveted sailmaker's palm with rawhide covered thimble.

ITEM #	STYLE #	STANDARD PACKAGE
254501	1	1



No. 254710

PENCIL – FABRIC MARKING

For clear, easy marking of fabrics in the cutting room. Trivantage® offers special pencils with either black, white or yellow lead. Yellow pencils can be wiped off vinyls but are difficult to remove from woven textiles. Black pencils can be used on white fabrics of any type and can be erased or wiped off easily. White pencils are also known as a “spit pencils.”

ITEM #	DESCRIPTION	FOR	STANDARD PACKAGE
254709	White Lead 1256 "Spit Pencil"	Vinyl, acrylic and woven fabrics	1/2 gross box (72 pencils)
254710	Yellow Lead	Vinyl and acrylic fabrics	1/2 gross box (72 pencils)
254711	Black Lead	White fabrics (any type)	1/2 gross box (72 pencils)

Trivantage® is a registered trademark of Glen Raven, Inc.



No. 255208

PINS – T

Used to secure fabric and make pattern before sewing. A very helpful aid when doing complex custom work, such as a boat top.

ITEM #	STYLE #	DESCRIPTION	LENGTH	MATERIAL	PUT UP	STANDARD PACKAGE
255208	32	T-Pins	2 in.	Steel	1/2 lb. box	1 gross



No. 255215

PINS – UPHOLSTERY

ITEM #	STYLE #	DESCRIPTION	LENGTH	MATERIAL	STANDARD PACKAGE
255215	190	Upholstery Pins	3 in.	Steel	1 gross



No. 214296

SPRING CLIP – STAINLESS STEEL

Used to carry hand tools.

ITEM #	STYLE #	SIZE	STANDARD PACKAGE
214296	301	0.020 in. x 7/8 in. x 3-3/8 in.	1000



No. 205066

TWIST AND SEAL

Twist and Seal is a device made of weather and UV resistant plastic and is used to protect outdoor electrical cord connections from rain and snow. Twist and Seal can be used on construction sites, and also for Christmas lights, and other decorations where outdoor cords need to be connected and protected from rain and snow.

Never submerge the Twist and Seal or any other electrical connection under water.

ITEM #	COLOR	SIZE
205066	Green	8 in. x 3-1/2 in. x 3-1/2 in.
205067	Orange	8 in. x 3-1/2 in. x 3-1/2 in.
205068	Blue	8 in. x 3-1/2 in. x 3-1/2 in.
205069	White	8 in. x 3-1/2 in. x 3-1/2 in.



No. 200795

ANCHOR – POOL COVER

The No. 50 deluxe brass anchor remains flush with the pool deck when not in use, and is highly corrosion resistant. It allows the cover to be easily and securely installed by unscrewing the bolt to receive “S” hooks on a rubber tie, a rubber tie hole, or the rounded ring end of the stainless steel spring. There are no threads to strip at the top of the bolt.

For use with Spring – Pool Cover (Item no. 200797).

ITEM #	STYLE #	DESCRIPTION	MATERIAL
200795	50	Pool Anchor	Brass



No. 200797

SPRING – POOL COVER

ITEM #	LENGTH	MATERIAL
200797	7.5 in.	Stainless Steel Type 304
273795	8 in.	Stainless Steel



No. 274511

TIES – CABLE

Specially treated for outdoor exposure, these PVC cable ties are designed to allow uniform tightening. Plus, they require less time than traditional lacing cord. These ties are an ideal solution for a professional appearance at a low cost.

ITEM #	STYLE #	COLOR	LENGTH	STANDARD PACKAGE
274511	T50ROM4	Black	8 in.	1000



No. 274515

TIES – AWNING

These aluminum ties are flexible and very easy to use. Will not rust or stain. Can be reused.

ITEM #	STYLE #	LENGTH	STANDARD PACKAGE
274515	5	5 in.	200



No. 239801

HOOK – S

Zinc-plated steel wire.



No. 239924

ITEM #	STYLE #	SIZE OPENING	STANDARD PACKAGE
239801	1	3/8 in.	100
239803	3	5/8 in.	100
239924	24	1-1/8 in.	50



No. 239100

HOOK – ROPE

Aluminum. Used to secure tarpaulins.

ITEM #	SIZE	STANDARD PACKAGE
239100	2-5/8 in.	100



No. 239401

HOOK – TARP BINDING

Cold drawn steel with zinc-plated finish, designed primarily to hold tarp ropes securely on truck bodies. Can be used in any industry where ropes are used, and where rope must be held tight.

ITEM #	STYLE #	DESCRIPTION	DIAMETER HOLE	HOOK OPENING	LENGTH	STANDARD PACKAGE	WIRE DIAMETER
239401	12011	Hook No. 5	1/4 in.	1 in.	3-3/4 in.	100	0.365 in.
239402	12010	Hook No. 3	3/16 in.	5/8 in.	2 in.	100	0.250 in.
239452	12009	Hook No. 52C	3/16 in.	7/16 in.	1-1/2 in.	100	0.192 in.



No. 226002

SCREW EYE

Zinc-plated finish – with sharp gimlet points for quick starting.



No. 226008



No. 226010

ITEM #	STYLE #	INSIDE DIAMETER EYE	LENGTH SHANK	LENGTH	STANDARD PACKAGE	WIRE DIAMETER
226002	2	23/32 in.	1-15/32 in.	2-5/8 in.	50	0.263 in.
226008	8	15/32 in.	13/16 in.	1-5/8 in.	100	0.162 in.
226010	10	13/32 in.	11/16 in.	1-3/8 in.	100	0.135 in.



No. 226085

SCREW EYE – LONG SHANK

Zinc-plated. For fastening through wood shingles.

ITEM #	STYLE #	INSIDE DIAMETER EYE	LENGTH SHANK	LENGTH
226085	8-1/2	1/2 in.	1-3/8 in.	2-5/16 in.



No. 226108

SCREW EYE – OPEN EYE

Zinc-plated finish with sharp gimlet points for starting.

ITEM #	STYLE #	STANDARD PACKAGE
226108	8	100



No. 260920



No. 261012

O RING

ITEM #	DIAMETER OF STOCK	FINISH	GAUGE	INSIDE DIAMETER OF RING	MATERIAL	STANDARD PACKAGE
260902	0.177 in.	Chrome Plated	9	1 in.	Zinc Die-Cast	500
260903	3/32 in.		13	3/8 in.	Zinc Die-Cast	1000
260905	3/32 in.	Nickel Plated	12	5/8 in.	Steel	500
260906	1/8 in.		11	3/4 in.	Zinc Die-Cast	1000
260920		Nickel Plated			Steel (Welded)	100
261004	1-1/2 in.	Cadmium	3	1-1/2 in.	Steel	750
261005	1-3/64 in.	Cadmium	6	1-1/4 in.	Steel	100
261007	11/32 in.	Cadmium	0	1-3/4 in.	Steel	100
261008	11/32 in.	Cadmium	0	2 in.	Steel	100
261009	3/8 in.	Cadmium	000	2-1/4 in.	Steel	100
261010	3/8 in.	Cadmium	000	2-1/2 in.	Steel	100
261011	3/8 in.	Cadmium	000	2-3/4 in.	Steel	100
261012	3/8 in.	Cadmium	000	3 in.	Steel	50
261102	0.177 in.			1 in.	316 Stainless Steel	100



No. 249195

SPRING – SNAP LINK

Zinc-plated steel.

ITEM #	STYLE #	DESCRIPTION	STANDARD PACKAGE
249195	245M-50M	1.97 in. x 5 mm wire	
266677	245M-50M	1.97 in. x 5 mm wire	100



No. 269115

GOLDLINE® EPDM TIE-DOWN AND TARP STRAP

Straps reinforced at hook ends. Hooks are 2-1/2 inch and where included come in a quantity of 2.

To determine strap size, let maximum stretch length, below, be your guide. For example, if distance between tarp grommet and trailer tie-down bar is 24 inch, order a 15 inch strap which provides a maximum 25 inch stretch length. If distance is 27 inch, order a 21 inch strap with maximum 34 inch stretch length.

Where hooks are inserted, or included loose, we supply two hooks per strap, or 100 pieces.

ITEM #	STYLE #	DESCRIPTION	LENGTH OVERALL WITH HOOK	MAXIMUM STRETCH WITH HOOK	STANDARD PACKAGE	TARP STRAP LENGTH
269109	635197920	Strap without Hooks	13 in.	18 in.	50	10 in.
269115	635197820	Strap without Hooks	18 in.	25 in.	50	15 in.
269120	635196920	Strap without Hooks	24 in.	34 in.	50	21 in.
269210	635197930	Strap with Hooks Loose in Box	13 in.	18 in.	50	10 in.
269215	635197830	Strap with Hooks Loose in Box	18 in.	25 in.	50	15 in.
269221	635196930	Strap with Hooks Loose in Box	24 in.	34 in.	50	21 in.
269231	635197730	Strap with Hooks Loose in Box	34 in.	49 in.	50	31 in.
269310	635197940	Strap with Hooks Inserted	13 in.	18 in.	50	10 in.
269315	635197840	Strap with Hooks Inserted	18 in.	25 in.	50	15 in.
269321	635196940	Strap with Hooks Inserted	24 in.	34 in.	50	21 in.
269331	635197740	Strap with Hooks Inserted	34 in.	49 in.	50	31 in.
269341	635738940	Strap with Hooks Inserted	44 in.	66 in.	50	41 in.

UNIVERSAL POLYMER Warning for EPDM TARP AND TIE-DOWN STRAPS: Observe maximum stretch warnings. Straps should not be stretched more than 50% of their normal length. Sudden disconnect in a stretched position may cause serious eye injury. Wear safety glasses during tie down and disconnect. Inspect straps before each use. Discard if abraded, cut or cracked. Straps should not be substituted as primary tie-down device for load.

Goldline® is a registered trademark of Universal Polymer & Rubber LTD.



No. 269200

HOOK – TARP STRAP “S”

ITEM #	LENGTH	MATERIAL	STANDARD PACKAGE
269200	2-1/2 in.	Stainless Steel	100
269202	2-1/2 in.	Galvanized Steel	100
269204	4-1/2 in.	Galvanized Steel	100



No. 261992

TIE-DOWN – EPDM ROPE STANDARD BLACK

Use anywhere constant tension is needed. Just cut the cord to the length required, apply the galvanized double eye hooks at both ends, and it’s ready for use. Will not crack, chip or peel. Use in any weather.

ITEM #	STYLE #	DESCRIPTION	PUT UP	ROPE SIZE	WEIGHT
261990	933037501	Display Carton	200 ft. coil with 150 double eye hooks	3/8 in.	22 lbs.
261991	933037502	Refill	200 ft. coil	3/8 in.	13 lbs.
261992	933043702	Display Carton	800 ft. coil	3/8 in.	50 lbs.

UNIVERSAL POLYMER Warning for EPDM ROPE TIE-DOWNS: Sudden disconnect in a stretched position may cause serious eye injury. Wear safety glasses during tie down and disconnect. Inspect before use. Discard if abraded, cut or cracked. Coil only in Display Carton.



No. 261993

TIE-DOWN – EPDM ROPE HEAVY DUTY BLACK

Use anywhere constant tension is needed. Just cut the cord to the length required, apply the galvanized double eye hooks at both ends, and it's ready for use. Will not crack, chip or peel. Use in any weather.



No. 261996

ITEM #	STYLE #	DESCRIPTION	PUT UP	ROPE SIZE	STANDARD PACKAGE	WEIGHT
261993	933043702	Display Carton	150 ft. coil with 150 double eye hooks	7/16 in.		22 lbs.
261994	933043701	Refill	150 ft. coil	7/16 in.		13 lbs.
261995	933043703	Display Carton	600 ft. coil	7/16 in.		48 lbs.
261996		Galvanized Double Eye Hooks			1000	

UNIVERSAL POLYMER Warning for EPDM ROPE TIE-DOWNS: Sudden disconnect in a stretched position may cause serious eye injury. Wear safety glasses during tie down and disconnect. Inspect before use. Discard if abraded, cut or cracked. Coil only in Display Carton.



No. 266625

SNAP – BOLT

Malleable iron, loop eye. Cadmium plated.

ITEM #	STYLE #	LENGTH	STANDARD PACKAGE	WEBBING SIZE
266625	25	3-1/4 in.	10	1 in.
266679	25	3-1/4 in.	10	1 in.



No. 266675

SNAP – CURTAIN TRIGGER

Made of malleable iron. Used to fasten down roller curtains. Cadmium plated.

ITEM #	STYLE #	LENGTH	STANDARD PACKAGE	WEBBING SIZE
266675	204	1-3/4 in.	10	3/4 in.



No. 266672

SNAP – SPRING

ITEM #	STYLE #	FINISH	MATERIAL	LENGTH	STANDARD PACKAGE	WEBBING SIZE
266672	200	Cadmium Plated	Malleable Iron	3-9/16 in.	10	1-1/2 in.
266673	200	Cadmium Plated	Malleable Iron	3-1/16 in.	10	1 in.
266674	200	Cadmium Plated	Malleable Iron	3-3/4 in.	10	2 in.
266681	142-A	Nickel Plated	Steel		100	1-1/2 in.
266767	249	Brass	Brass	2-1/2 in.	100	3/4 in.
266876	349		Stainless Steel		100	1 in.
266895	5016	Nickel Plated	Steel	2-5/8 in.	100	1 in.
266903	5350	Nickel Plated	Steel	1-3/4 in.	200	3/4 in.
266904	5350	Nickel Plated	Steel	1-3/4 in.	20	1 in.



No. 266895



No. 266903

SNAP – TENT WALL

ITEM #	STYLE #	FINISH	MATERIAL	STANDARD PACKAGE	WEBBING SIZE
266893	340	Nickel Plated	Zinc Die-Cast	500	1 in.



No. 266762

SNAP – WIRE

Zinc and nickel plated steel. Also available in Stainless Steel.

ITEM #	STYLE #	FINISH	MATERIAL	LENGTH	STANDARD PACKAGE	WEBBING SIZE
266739	142-A	Nickel Plated	Steel	2-1/8 in.	100	1-1/2 in.
266741	142-A	Zinc Plated	Steel	2-1/8 in.	100	1 in.
266762	14201	Nickel Plated	Steel	2-1/8 in.	100	1 in.



KEDER RAIL

Aluminum.

ITEM #	STYLE #	BEAD SIZE	LENGTH
578164	48.6025.31.05	17 mm	16.4 ft.
578165	48.6025.31.025	17 mm	8.2 ft.
578166	48.5524.31.05	18 mm	16.4 ft.
578167	48.5524.31.025	18 mm	8.2 ft.



No. 101603

RING AND TRIANGLE WEB ASSEMBLY

Triangles with link are mounted on 2-1/4 inch O.D. by 3/8 in. diameter welded steel ring. Heavy-duty welded wire triangles with link. Plated for maximum weather protection. Will accommodate webbing up to 2 inch in width.

ITEM #	STYLE #	DESCRIPTION	FOR	STANDARD PACKAGE
101603	3	3 Triangles on Welded Ring	End center poles on small tents	15



No. 578160

CROCODILE HANGER®

Crocodile Hangers combine the strong sliding and movement features of Ball Hooks with the durability of Bar Sliders. The composition and design allows excellent durability for use in a range of environments.



No. 578161

ITEM #	STYLE #	DESCRIPTION	SIZE	STANDARD PACKAGE
578160	35.0927.41	Ball Hook		
578161	35.2727.41	Calott Slider	9 mm	
578162	35.8027.41.21	Kedar Track Roller with Screw Caps	9 mm	100
578163	25.8309.18	Stainless Steel Screws		100



No. 578162



No. 578163

Crocodile Hanger® is a registered trademark of American Keder, Inc.



No. 266514

TENT SLIDE

Stamped galvanized steel.

ITEM #	STYLE #	LENGTH	ROPE SIZE	STANDARD PACKAGE
266514	4	4 in.	5/16 in.	500



No. 267306

TRAILER AWNING SPRING

Designed to equalize tension on guy lines of trailer awnings and eliminate adjustment. Equipped with loops at each end for rope fastening. Made of high-grade wire to provide flexibility. Zinc-plated.

ITEM #	LENGTH	STANDARD PACKAGE
267306	4-5/8 in.	1



No. 130609

EAVE WEB GUY FITTING

A plated, stamped steel fitting to accommodate supporting web, pole and guy line. Fitting has a round hole for guy line, 7/8 inch hole for side pole, and oblong hole for webbing. Fitting is also designed for attachment of eave rope. Will accommodate webbing up to 2 inch in width.

ITEM #	STYLE #	STANDARD PACKAGE
130609	162	25



No. 267612

TENT STAKE – STEEL

Formed of heavy-gauge, precoated galvanized steel. Specially designed top provides maximum strength with minimum weight.

ITEM #	LENGTH	STANDARD PACKAGE
267609	9 in.	100
267612	12 in.	100
267615	15 in.	100



No. 267710

TENT STAKE – KINKED WIRE

A sturdy all-steel tent stake with slash-cut end, and kinked body made of 1/4 in. diameter steel. Bright zinc plating adds lasting protection. Can also be used for ground fastening of sunshades, wind baffles and privacy screens.

ITEM #	LENGTH	STANDARD PACKAGE
267709	9 in.	100
267710	9 in.	1000



No. 267500

TENT STAKE – POLYPROPYLENE

Made to withstand heavy usage. Superior strength in temperature extremes.

ITEM #	COLOR	LENGTH	STANDARD PACKAGE
267500	Yellow	9 in.	300

YKK® AQUAGUARD®

AquaGuard zippers have a shiny polyurethane coating with an embossed finish that sheds water, as well as enhancing the appearance. These zippers can be RF welded, ultrasonically bonded or sewn.

ITEM #	STYLE #	COLOR	LENGTH	STANDARD PACKAGE
280869	UR CT40L-101 DFBL 67752	Black	240 in.	1

YKK® and AquaGuard® are registered trademarks of YKK Corporation.



No. 280331

YKK® VISLON® 10VF NO. 10 VISLON SLIDERS – METAL

ITEM #	STYLE #	DESCRIPTION	COLOR	COLOR NUMBER	STANDARD PACKAGE
280330	10VDFW	Non-Locking Short Single Pull Tab	White	501	100
280331	10VDFW	Non-Locking Short Single Pull Tab	Black	580	100
280332	10VDFWW	Non-Locking Short Double Pull Tab	White	501	100
280334	10VFDA	AutoLok Single Pull	White	501	1000
280336	10CFDX	AutoLok Double Pull	White	501	100
280362	10VFDA	AutoLok Single Pull	Black	580	100
280363	10VFDX	AutoLok Double Pull	Black	580	600
280369	10VDFWW	Non-Locking Short Double Pull Tab	Black	580	100
280595	10VFDA	AutoLok Single Pull	Light Beige		1000
280872	10VFDWL	Non-Locking Long Double Pull Tab	White	501	100
280873	10VFDWL	Non-Locking Long Double Pull Tab	Black	580	100
280950	10VDFL	Non-Locking Single Pull	Black	580	100

YKK® and Vislon® are registered trademarks of YKK Corporation.



No. 280361

YKK® VISLON® 10VF NO. 10 VISLON SLIDERS – PLASTIC

ITEM #	STYLE #	DESCRIPTION	COLOR	COLOR NUMBER	STANDARD PACKAGE
280360	10VFTA	AutoLok Single Pull	White	501	100
280361	10VFTA	AutoLok Single Pull	Black	580	100
280364	10VFTX	AutoLok Double Pull	White	501	100
280365	10VFTX	AutoLok Double Pull	Black	580	100
280366	10VFTW	Non-Locking Short Double Pull Tab	White	501	100

YKK® and Vislon® are registered trademarks of YKK Corporation.



No. 280311

YKK® VISLON® 10VFUV NO. 10 VISLON CHAIN (VF)

ITEM #	STYLE #	COLOR	COLOR NUMBER	STANDARD PACKAGE	WIDTH
280307	10VF	White	501	55 yds.	11/16 in.
280309	10VF	Black	580	55 yds.	11/16 in.
280311	10VF	Black	580	109 yds.	11/16 in.
299398	10VF	White	501	109 yds.	11/16 in.

YKK® and Vislon® are registered trademarks of YKK Corporation.



No. 295641

YKK® VISLON® 5VS NO. 5 VISLON SLIDERS – METAL

ITEM #	STYLE #	DESCRIPTION	COLOR	COLOR NUMBER	STANDARD PACKAGE
295640	5VSDFL	Non-Locking Long Single Pull Tab	White	501	100
295641	5VSDFL	Non-Locking Long Single Pull Tab	Black	580	100
295642	5VSDFL	Non-Locking Long Single Pull Tab	Beige	573	100
295645	5VSDFW	Non-Locking Short Single Pull Tab	White	501	100
295646	5VSDFW	Non-Locking Short Single Pull Tab	Black	580	100
295649	5VSDWL	Non-Locking Long Double Pull Tab	White	501	100
295650	5VSDWL	Non-Locking Long Double Pull Tab	Black	580	100
295653	5VSDA	AutoLok Standard Single Pull Tab	White	501	100
295654	5VSDA	AutoLok Standard Single Pull Tab	Black	580	100
295657	5VSDXL	AutoLok Standard Double Pull Tab	White	501	100
295658	5VSDXL	AutoLok Standard Double Pull Tab	Black	580	100

YKK® and Vislon® are registered trademarks of YKK Corporation.



No. 295670

YKK® VISLON® 5VS NO. 5 VISLON SLIDERS – PLASTIC

ITEM #	STYLE #	DESCRIPTION	COLOR	COLOR NUMBER	STANDARD PACKAGE
295661	5VSTF	Non-Locking Short Single Pull Tab	White	501	100
295662	5VSTF	Non-Locking Short Single Pull Tab	Black	580	100
295665	5VSTW	Non-Locking Short Double Pull Tab	White	501	100
295669	5VSTA	AutoLok Standard Single Pull Tab	White	501	100
295670	5VSTA	AutoLok Standard Single Pull Tab	Black	580	100
295674	5VSTX	AutoLok Standard Double Pull Tab	Black	580	100

YKK® and Vislon® are registered trademarks of YKK Corporation.



No. 295627

YKK® VISLON® 5VS NO. 5 VISLON CHAIN

ITEM #	STYLE #	COLOR	COLOR NUMBER	STANDARD PACKAGE	WIDTH
295625	5VS	White	501	109 yds.	9/16 in.
295626	5VS	White	501	218 yds.	9/16 in.
295627	5VS	Black	580	109 yds.	9/16 in.
295628	5VS	Black	580	218 yds.	9/16 in.
295630	5VS	Beige	573	218 yds.	9/16 in.

YKK® and Vislon® are registered trademarks of YKK Corporation.



No. 280922

YKK® VISLON® 8VF NO. 8 VISLON SLIDERS – METAL

ITEM #	STYLE #	DESCRIPTION	COLOR	COLOR NUMBER	STANDARD PACKAGE
280920	8VFDA	AutoLok Single Pull	White	501	100
280922	8VFDA	AutoLok Single Pull	Black	580	100
280926	8VFDXL	AutoLok Long Double Pull Tab	White	501	1000
280938	8VFDXL	AutoLok Long Double Pull Tab	Black	580	1000

YKK® and Vislon® are registered trademarks of YKK Corporation.



No. 280910

YKK® VISLON® 8VFUV NO. 8 VISLON CHAIN

ITEM #	STYLE #	COLOR	COLOR NUMBER	STANDARD PACKAGE	WIDTH
280900	8VFUV	White	501	137 yds.	5/8 in.
280910	8VFUV	Black	580	137 yds.	5/8 in.

YKK® and Vislon® are registered trademarks of YKK Corporation.



No. 279836

YKK® ZIPLON® SLIDERS – METAL

ITEM #	STYLE #	DESCRIPTION	COLOR	COLOR NUMBER	FINISH	STANDARD PACKAGE
279835	5CNDA5	AutoLok Single Pull Tab	White	501		100
279836	5CNDA5	AutoLok Single Pull Tab	Black	580		100
279839	10CFDFBL	AutoLok Single Pull Tab (Reversed)			Nickel Plated	100
279840	5CNDFL	Non-Locking Long Single Pull Tab	White	501		100
279841	5CNDFL	Non-Locking Long Single Pull Tab	Black	580		100
279842	5CNDFL	Non-Locking Long Single Pull Tab			Nickel Plated	100
279845	5CNDW3L	Non-Locking Long Double Pull Tab	White	501		100
279846	5CNDW3L	Non-Locking Long Double Pull Tab	Black	580		100
280317	4.5CNDFL	Non-Locking Long Single Pull Tab			Nickel Plated	100
280319	4.5CNDFL	Non-Locking Long Single Pull Tab	Black	580		100
280338	10CFDFL	Non-Locking Long Single Pull Tab			Nickel Plated	100
280339	10CFDWL	Non-Locking Long Double Pull Tab	White	501		100
280341	8CFDWL	Non-Locking Long Double Pull Tab	Black	580		100
280348	10CFDFL	Non-Locking Long Single Pull Tab	Black	580		100
280349	10CFDFL	Non-Locking Long Single Pull Tab	White	501		100
280368	10CFDWL	Non-Locking Long Double Pull Tab	Black	580		100
280510	8CFFDFL	Non-Locking Long Single Pull Tab	White	501		100
280511	10CFDA3	AutoLok Single Pull	White	501		100
280512	10CFDA3	AutoLok Single Pull	Black	580		100
280514	8CNDFL	Non-Locking Long Single Pull Tab	Black	580		100
280515	8CNDFL	Non-Locking Long Single Pull Tab			Nickel Plated	100

YKK® and Ziplon® are registered trademarks of YKK Corporation.



No. 279831

YKK® ZIPLON® ZIPLON CHAIN (CF)

ITEM #	STYLE #	COLOR	COLOR NUMBER	STANDARD PACKAGE	WIDTH
279830	5CF	White	501	218 yds.	5/8 in.
279831	5CF	Black	580	218 yds.	5/8 in.
280290	4.5CF	White	501	218 yds.	5/8 in.
280291	4.5CF	Black	580	218 yds.	5/8 in.
280315	10CF	White	501	109 yds.	3/4 in.
280316	10CF	Black	580	109 yds.	3/4 in.
280502	9CF	Black	580	109 yds.	3/4 in.
280504	8CF	White	501	165 yds.	3/4 in.
280505	8CF	Black	580	165 yds.	3/4 in.
280509	8CF	Beige	573	165 yds.	3/4 in.
280591	8CF	Black	580	165 yds.	5/8 in.

YKK® and Ziplon® are registered trademarks of YKK Corporation.



No. 586090

YKK® PULL CORD

ITEM #	STYLE #	COLOR	CORD SIZE	LENGTH
586090	LCWE	Black	1/10 in.	4.5 in.

YKK® is a registered trademark of YKK Corporation.



No. 280492

YKK® VISLON® BOTTOM STOPS

ITEM #	STYLE #	COLOR	COLOR NUMBER	STANDARD PACKAGE
280492	10 VF	Black	580	100
280550	10 VF	White	501	100
295680	5 VS	White	501	100
295681	5 VS	Black	580	100

YKK® and Vislon® are registered trademarks of YKK Corporation.



No. 280493

YKK® VISLON® TOP STOPS

ITEM #	STYLE #	COLOR	COLOR NUMBER	STANDARD PACKAGE
280493	10 VF	Black	580	100
280547	10 VF	White	501	100
295682	5 VS	White	501	100
295683	5 VS	Black	580	100

YKK® and Vislon® are registered trademarks of YKK Corporation.



No. 280490

YKK® SNAPCAP™

This revolutionary zipper top-stop is ready for assembling. Available in black and white.

ITEM #	COLOR	COLOR NUMBER	STANDARD PACKAGE
280490	Black	580	2000
280491	White	501	2000

SnapCap™ is a trademark and YKK® is a registered trademark of YKK Corporation.



No. 280974

TOP STOP NO. 10

No. 10 Zipper Top Stop is placed over a tooth on each side of the zipper and bent in place with pliers. It eliminates the need to cut the zipper and chain with a hot knife or sew it down to form a stop. Providing added flexibility, the Stainless Steel Zipper Top Stop can be moved if needed.

ITEM #	STYLE #	MATERIAL	STANDARD PACKAGE
280974	89001	Stainless Steel	1000



No. 255251

ZIPPER TOOLS – ZIPPER STOP

Convenient tool designed specifically to apply Zipper Stop to zipper chain, helping eliminate slippage and rotation of the stop. Features a special groove that firmly holds zipper stop in place.

ITEM #	STYLE #
255251	1012



No. 255252

ZIPPER TOOLS – ZIPPER JIG

Save time during zipper installations with the Zipper Jig. This handy tool holds YKK® zipper sliders from #2.5 to #10, allowing you to easily install sliders. The lower clamp securely holds the Zipper Jig to a counter, while the upper clamp is used to lock the jig rod in any direction. It even allows you to put a zipper on backwards. The Zipper Jig is 5-1/2 inch x 4-3/4 inch, making it ideal for workstations.



To use simply place the slider upside-down and facing forward into the slot on the rod. Open the zipper one or two inches and hold face down. Feed both sides evenly into the slider held by the rod, coming in at a 45 degree angle. Pull forward and it's done!

ITEM #	STYLE #
255252	1014

YKK® is a registered trademark of YKK Corporation.



No. 279868

**YKK® VISLON® UV VFUV NO. 10
SEPARATING ZIPPER AUTOMATIC LOCK –
DOUBLE PULL METAL SLIDER**

Engineered especially for marine applications. All element and slider materials are scientifically designed to resist damage from sunlight as well as corrosion. Teeth injection-molded from DuPont™ Delrin®.

UV-resistant acetal resin attached to a strong cord and tape, which ensure the sliders stay on track. The Delrin polymer reduces the effect of ultraviolet radiation, significantly increasing its useful life.

ITEM #	STYLE #	COLOR	COLOR NUMBER	LENGTH	STANDARD PACKAGE
279868	VFUV	Black	41578	144 in.	10

YKK® and Vislon® are registered trademarks of YKK Corporation. Dupont™ is a trademark of E.I. Dupont de Nemours and Company, Inc. Delrin® is a registered trademark of E.I. Dupont de Nemours and Company, Inc.

**YKK® VISLON® UV VFUV NO. 10
SEPARATING ZIPPER AUTOMATIC LOCK –
DOUBLE PULL NYLON SLIDER**

Engineered especially for marine applications. All element and slider materials are scientifically designed to resist damage from sunlight as well as corrosion. Teeth injection-molded from DuPont™ Delrin®.

UV-resistant acetal resin attached to a strong cord and tape, which ensure the sliders stay on track. The Delrin polymer reduces the effect of ultraviolet radiation, significantly increasing its useful life.

ITEM #	STYLE #	COLOR	COLOR NUMBER	LENGTH	STANDARD PACKAGE
279866	VFUV	Black	32241	78 in.	10

YKK® and Vislon® are registered trademarks of YKK Corporation. Dupont™ is a trademark of E.I. Dupont de Nemours and Company, Inc. Delrin® is a registered trademark of E.I. Dupont de Nemours and Company, Inc.

**YKK® VISLON® UV VFUV NO. 10
SEPARATING ZIPPER AUTOMATIC LOCK –
SINGLE PULL METAL SLIDER**

Engineered especially for marine applications. All element and slider materials are scientifically designed to resist damage from sunlight as well as corrosion. Teeth injection-molded from DuPont™ Delrin®.

UV-resistant acetal resin attached to a strong cord and tape, which ensure the sliders stay on track. The Delrin polymer reduces the effect of ultraviolet radiation, significantly increasing its useful life.

ITEM #	STYLE #	COLOR	COLOR NUMBER	LENGTH	STANDARD PACKAGE
279872	VFUV	Black	32483	108 in.	10

YKK® and Vislon® are registered trademarks of YKK Corporation. Dupont™ is a trademark of E.I. Dupont de Nemours and Company, Inc. Delrin® is a registered trademark of E.I. Dupont de Nemours and Company, Inc.



No. 279893

**YKK® VISLON® UV VFUV NO. 8
SEPARATING ZIPPER NON-LOCKING –
DOUBLE PULL METAL SLIDER**

Engineered especially for marine applications. All element and slider materials are scientifically designed to resist damage from sunlight as well as corrosion. Teeth injection-molded from DuPont™ Delrin®.

UV-resistant acetal resin attached to a strong cord and tape, which ensure the sliders stay on track. The Delrin polymer reduces the effect of ultraviolet radiation, significantly increasing its useful life.

ITEM #	STYLE #	COLOR	COLOR NUMBER	LENGTH	STANDARD PACKAGE
279875	VFUV	White	32438	18 in.	10
279876	VFUV	White	32438	24 in.	10
279878	VFUV	White	32438	36 in.	10
279879	VFUV	White	32438	42 in.	10
279880	VFUV	White	32438	48 in.	10
279881	VFUV	White	32438	54 in.	10
279882	VFUV	White	32438	60 in.	10
279884	VFUV	White	32438	72 in.	10
279890	VFUV	Black	32238	18 in.	10
279891	VFUV	Black	32238	24 in.	10
279893	VFUV	Black	32238	36 in.	10
279895	VFUV	Black	32238	42 in.	10
279896	VFUV	Black	32238	48 in.	10
279897	VFUV	Black	32238	54 in.	10
279898	VFUV	Black	32238	60 in.	10
279900	VFUV	Black	32238	72 in.	10

YKK® and Vislon® are registered trademarks of YKK Corporation. Dupont™ is a trademark of E.I. Dupont de Nemours and Company, Inc. Delrin® is a registered trademark of E.I. Dupont de Nemours and Company, Inc.



No. 296215

YKK® VISLON® VFOL105W NO. 10 SEPARATING ZIPPER NON-LOCKING – DOUBLE PULL METAL SLIDER

YKK No. 10 Vislon Separating Zippers are extremely strong and lightweight and differ from conventional zippers, because the “teeth” are made from Delrin® and the tape is polyester. Because of the unique properties of the Vislon Zipper, it has a wide variety of industrial, consumer and military applications where environmental conditions reduce the effectiveness of metal zippers.

The Vislon Zipper is corrosion resistant. The zipper is self-lubricating and operates smoothly despite mud, sand, etc. The color is an integral part of the molding material, creating a finish that does not rub off, peel or chip.

ITEM #	STYLE #	COLOR	COLOR NUMBER	LENGTH	STANDARD PACKAGE
296215	VFOL105W	Black	580	60 in.	10
296234	VFOL105W	Onion	801	72 in.	10

YKK® and Vislon® are registered trademarks of YKK Corporation. Delrin® is a registered trademark of E.I. DuPont de Nemours and Company, Inc.



No. 280243

YKK® VISLON® VFULVOL-107 DX E NO. 10 SEPARATING ZIPPER WITH AUTOMATIC LOCK – SHORT DOUBLE PULL METAL SLIDER

YKK No. 10 Vislon Separating Zippers are extremely strong and lightweight and differ from conventional zippers, because the “teeth” are made from Delrin® and the tape is polyester. Because of the unique properties of the Vislon Zipper, it has a wide variety of industrial, consumer and military applications where environmental conditions reduce the effectiveness of metal zippers.

The Vislon Zipper is corrosion resistant. The zipper is self-lubricating and operates smoothly despite mud, sand, etc. The color is an integral part of the molding material, creating a finish that does not rub off, peel or chip.

ITEM #	STYLE #	COLOR	COLOR NUMBER	LENGTH	STANDARD PACKAGE
280243	VFULVOL-107 DX E	Natural	572	96 in.	10

YKK® and Vislon® are registered trademarks of YKK Corporation. Delrin® is a registered trademark of E.I. DuPont de Nemours and Company, Inc.



No. 280596

YKK® VISLON® VFUL106 TA NO. 10 SEPARATING ZIPPER WITH AUTOMATIC LOCK – SHORT SINGLE PULL PLASTIC SLIDER

YKK No. 10 Vislon Separating Zippers are extremely strong and lightweight and differ from conventional zippers, because the “teeth” are made from Delrin® and the tape is polyester. Because of the unique properties of the Vislon Zipper, it has a wide variety of industrial, consumer and military applications where environmental conditions reduce the effectiveness of metal zippers.

The Vislon Zipper is corrosion resistant. The zipper is self-lubricating and operates smoothly despite mud, sand, etc. The color is an integral part of the molding material, creating a finish that does not rub off, peel or chip.

ITEM #	STYLE #	COLOR	COLOR NUMBER	LENGTH	STANDARD PACKAGE
280520	VFUL106 TA	White	501	24 in.	10
280522	VFUL106 TA	White	501	36 in.	10
280528	VFUL106 TA	White	501	48 in.	10
280532	VFUL106 TA	White	501	60 in.	10
280536	VFUL106 TA	White	501	72 in.	10
280538	VFUL106 TA	White	501	84 in.	10
280540	VFUL106 TA	White	501	96 in.	10
280548	VFUL106 TA	White	501	120 in.	10
280596	VFUL106 TA	Black	580	24 in.	10
280598	VFUL106 TA	Black	580	26 in.	10
280604	VFUL106 TA	Black	580	48 in.	10
280606	VFUL106 TA	Black	580	60 in.	10
280608	VFUL106 TA	Black	580	72 in.	10
280612	VFUL106 TA	Black	580	96 in.	10
280617	VFUL106 TA	Black	580	108 in.	10
280619	VFUL106 TA	Black	580	120 in.	10

YKK® and Vislon® are registered trademarks of YKK Corporation. Delrin® is a registered trademark of E.I. DuPont de Nemours and Company, Inc.



No. 296180

ZIPPER – YKK® VISLON® VFUVOL-106 DA E NO. 10 SEPARATING ZIPPER WITH AUTOMATIC LOCK – SHORT SINGLE PULL METAL SLIDER

YKK No. 10 Vislon Separating Zippers are extremely strong and lightweight and differ from conventional zippers, because the “teeth” are made from Delrin® and the tape is polyester. Because of the unique properties of the Vislon Zipper, it has a wide variety of industrial, consumer and military applications where environmental conditions reduce the effectiveness of metal zippers.

The Vislon Zipper is corrosion resistant. The zipper is self-lubricating and operates smoothly despite mud, sand, etc. The color is an integral part of the molding material, creating a finish that does not rub off, peel or chip.

ITEM #	STYLE #	COLOR	COLOR NUMBER	LENGTH	STANDARD PACKAGE
296156	VFUVOL-106 DA E	White	501	18 in.	10
296160	VFUVOL-106 DA E	White	501	24 in.	10
296162	VFUVOL-106 DA E	White	501	36 in.	10
296165	VFUVOL-106 DA E	White	501	48 in.	10
296167	VFUVOL-106 DA E	White	501	60 in.	10
296170	VFUVOL-106 DA E	White	501	72 in.	10
296172	VFUVOL-106 DA E	White	501	84 in.	10
296174	VFUVOL-106 DA E	White	501	96 in.	10
296178	VFUVOL-106 DA E	White	501	120 in.	10
296179	VFUVOL-106 DA E	White	501	144 in.	10
296180	VFUVOL-106 DA E	Black	580	24 in.	10
296182	VFUVOL-106 DA E	Black	580	36 in.	10
296183	VFUVOL-106 DA E	Black	580	12 in.	10
296184	VFUVOL-106 DA E	Black	580	42 in.	10
296185	VFUVOL-106 DA E	Black	580	48 in.	10
296186	VFUVOL-106 DA E	Black	580	54 in.	10
296187	VFUVOL-106 DA E	Black	580	60 in.	10
296190	VFUVOL-106 DA E	Black	580	72 in.	10
296192	VFUVOL-106 DA E	Black	580	84 in.	10
296194	VFUVOL-106 DA E	Black	580	96 in.	10
296196	VFUVOL-106 DA E	Black	580	110 in.	10
296198	VFUVOL-106 DA E	Black	580	120 in.	10
296199	VFUVOL-106 DA E	Black	580	144 in.	10

YKK® and Vislon® are registered trademarks of YKK Corporation. Delrin® is a registered trademark of E.I. DuPont de Nemours and Company, Inc.



No. 296119

YKK® VISLON® VFUVOL-107 DX E NO. 10 SEPARATING ZIPPER WITH AUTOMATIC LOCK – SHORT DOUBLE PULL METAL SLIDER

YKK No. 10 Vislon Separating Zippers are extremely strong and lightweight and differ from conventional zippers, because the “teeth” are made from Delrin® and the tape is polyester. Because of the unique properties of the Vislon Zipper, it has a wide variety of industrial, consumer and military applications where environmental conditions reduce the effectiveness of metal zippers.

The Vislon Zipper is corrosion resistant. The zipper is self-lubricating and operates smoothly despite mud, sand, etc. The color is an integral part of the molding material, creating a finish that does not rub off, peel or chip.

ITEM #	STYLE #	COLOR	COLOR NUMBER	LENGTH	STANDARD PACKAGE	ITEM #	STYLE #	COLOR	COLOR NUMBER	LENGTH	STANDARD PACKAGE
296061	VFUVOL-107 DX E	White	501	18 in.	10	296142	VFUVOL-107 DX E	Black	580	68 in.	10
296063	VFUVOL-107 DX E	White	501	24 in.	10	296143	VFUVOL-107 DX E	Black	580	96 in.	10
296065	VFUVOL-107 DX E	White	501	30 in.	10	296144	VFUVOL-107 DX E	Black	580	76 in.	10
296068	VFUVOL-107 DX E	White	501	36 in.	10	296145	VFUVOL-107 DX E	Black	580	100 in.	10
296069	VFUVOL-107 DX E	White	501	40 in.	10	296146	VFUVOL-107 DX E	Black	580	80 in.	10
296070	VFUVOL-107 DX E	White	501	42 in.	10	296147	VFUVOL-107 DX E	Black	580	108 in.	10
296072	VFUVOL-107 DX E	White	501	48 in.	10	296148	VFUVOL-107 DX E	Black	580	90 in.	10
296074	VFUVOL-107 DX E	White	501	54 in.	10	296149	VFUVOL-107 DX E	Black	580	110 in.	10
296076	VFUVOL-107 DX E	White	501	60 in.	10	296151	VFUVOL-107 DX E	Black	580	120 in.	10
296080	VFUVOL-107 DX E	White	501	66 in.	10	296154	VFUVOL-107 DX E	Black	580	240 in.	10
296082	VFUVOL-107 DX E	White	501	72 in.	10	296233	VFUVOL-107 DX E	Light Beige	573	18 in.	10
296084	VFUVOL-107 DX E	White	501	78 in.	10	296236	VFUVOL-107 DX E	Light Beige	573	24 in.	10
296086	VFUVOL-107 DX E	White	501	84 in.	10	296237	VFUVOL-107 DX E	Light Beige	573	30 in.	10
296087	VFUVOL-107 DX E	White	501	90 in.	10	296239	VFUVOL-107 DX E	Light Beige	573	36 in.	10
296088	VFUVOL-107 DX E	White	501	96 in.	10	296242	VFUVOL-107 DX E	Light Beige	573	42 in.	10
296089	VFUVOL-107 DX E	White	501	100 in.	10	296245	VFUVOL-107 DX E	Light Beige	573	48 in.	10
296091	VFUVOL-107 DX E	White	501	108 in.	10	296248	VFUVOL-107 DX E	Light Beige	573	54 in.	10
296092	VFUVOL-107 DX E	White	501	110 in.	10	296251	VFUVOL-107 DX E	Light Beige	573	60 in.	10
296094	VFUVOL-107 DX E	White	501	120 in.	10	296254	VFUVOL-107 DX E	Light Beige	573	72 in.	10
296098	VFUVOL-107 DX E	White	501	144 in.	10	296257	VFUVOL-107 DX E	Light Beige	573	84 in.	10
296099	VFUVOL-107 DX E	White	501	154 in.	10	296260	VFUVOL-107 DX E	Light Beige	573	96 in.	10
296105	VFUVOL-107 DX E	White	501	240 in.	10	296265	VFUVOL-107 DX E	Light Beige	573	120 in.	10
296116	VFUVOL-107 DX E	Black	580	16 in.	10	296270	VFUVOL-107 DX E	Light Beige	573	144 in.	10
296118	VFUVOL-107 DX E	Black	580	12 in.	10						
296119	VFUVOL-107 DX E	Black	580	20 in.	10						
296120	VFUVOL-107 DX E	Black	580	18 in.	10						
296122	VFUVOL-107 DX E	Black	580	24 in.	10						
296124	VFUVOL-107 DX E	Black	580	30 in.	10						
296125	VFUVOL-107 DX E	Black	580	34 in.	10						
296126	VFUVOL-107 DX E	Black	580	36 in.	10						
296128	VFUVOL-107 DX E	Black	580	40 in.	10						
296129	VFUVOL-107 DX E	Black	580	42 in.	10						
296131	VFUVOL-107 DX E	Black	580	48 in.	10						
296133	VFUVOL-107 DX E	Black	580	54 in.	10						
296134	VFUVOL-107 DX E	Black	580	46 in.	10						
296135	VFUVOL-107 DX E	Black	580	60 in.	10						
296137	VFUVOL-107 DX E	Black	580	66 in.	10						
296139	VFUVOL-107 DX E	Black	580	72 in.	10						
296141	VFUVOL-107 DX E	Black	580	84 in.	10						

YKK® and Vislon® are registered trademarks of YKK Corporation. Delrin® is a registered trademark of E.I. DuPont de Nemours and Company, Inc.



No. 280692

YKK® VISLON® VFUVOL-86 DA E NO. 8 SEPARATING ZIPPER WITH AUTOMATIC LOCK – SHORT SINGLE PULL METAL SLIDER

YKK No. 8 Vislon Separating Zippers are extremely strong and lightweight and differ from conventional zippers, because the “teeth” are made from Delrin® and the tape is polyester. Because of the unique properties of the Vislon Zipper, it has a wide variety of industrial, consumer and military applications where environmental conditions reduce the effectiveness of metal zippers.

The Vislon Zipper is corrosion resistant. The zipper is self-lubricating and operates smoothly despite mud, sand, etc. The color is an integral part of the molding material, creating a finish that does not rub off, peel or chip.

ITEM #	STYLE #	COLOR	COLOR NUMBER	LENGTH	STANDARD PACKAGE
280681	VFUVOL-86 DA E	White	501	42 in.	10
280692	VFUVOL-86 DA E	Black	580	48 in.	10

YKK® and Vislon® are registered trademarks of YKK Corporation. Delrin® is a registered trademark of E.I. Dupont de Nemours and Company, Inc.



No. 280758

YKK® VISLON® VFUVOL-87 DXL E NO. 8 SEPARATING ZIPPER WITH AUTOMATIC LOCK – LONG DOUBLE PULL METAL SLIDER

YKK No. 8 Vislon Separating Zippers are extremely strong and lightweight and differ from conventional zippers, because the “teeth” are made from Delrin® and the tape is polyester. Because of the unique properties of the Vislon Zipper, it has a wide variety of industrial, consumer and military applications where environmental conditions reduce the effectiveness of metal zippers.

The Vislon Zipper is corrosion resistant. The zipper is self-lubricating and operates smoothly despite mud, sand, etc. The color is an integral part of the molding material, creating a finish that does not rub off, peel or chip.

ITEM #	STYLE #	COLOR	COLOR NUMBER	LENGTH	STANDARD PACKAGE	ITEM #	STYLE #	COLOR	COLOR NUMBER	LENGTH	STANDARD PACKAGE
280700	VFUVOL-87 DXL E	White	501	18 in.	10	280750	VFUVOL-87 DXL E	Black	580	42 in.	10
280702	VFUVOL-87 DXL E	White	501	24 in.	10	280752	VFUVOL-87 DXL E	Black	580	48 in.	10
280704	VFUVOL-87 DXL E	White	501	30 in.	10	280754	VFUVOL-87 DXL E	Black	580	54 in.	10
280706	VFUVOL-87 DXL E	White	501	36 in.	10	280756	VFUVOL-87 DXL E	Black	580	60 in.	10
280707	VFUVOL-87 DXL E	White	501	38 in.	10	280758	VFUVOL-87 DXL E	Black	580	66 in.	10
280710	VFUVOL-87 DXL E	White	501	42 in.	10	280760	VFUVOL-87 DXL E	Black	580	72 in.	10
280712	VFUVOL-87 DXL E	White	501	48 in.	10	280762	VFUVOL-87 DXL E	Black	580	78 in.	10
280714	VFUVOL-87 DXL E	White	501	54 in.	10	280764	VFUVOL-87 DXL E	Black	580	84 in.	10
280716	VFUVOL-87 DXL E	White	501	60 in.	10	280766	VFUVOL-87 DXL E	Black	580	96 in.	10
280717	VFUVOL-87 DXL E	White	501	56 in.	10	280770	VFUVOL-87 DXL E	Black	580	110 in.	10
280720	VFUVOL-87 DXL E	White	501	72 in.	10	280772	VFUVOL-87 DXL E	Black	580	120 in.	10
280722	VFUVOL-87 DXL E	White	501	78 in.	10	280787	VFUVOL-87 DXL E	Gray	576	38 in.	10
280724	VFUVOL-87 DXL E	White	501	84 in.	10	280792	VFUVOL-87 DXL E	Gray	576	48 in.	10
280726	VFUVOL-87 DXL E	White	501	96 in.	10	280796	VFUVOL-87 DXL E	Gray	576	60 in.	10
280730	VFUVOL-87 DXL E	White	501	110 in.	10	280800	VFUVOL-87 DXL E	Gray	576	72 in.	10
280732	VFUVOL-87 DXL E	White	501	120 in.	10	280804	VFUVOL-87 DXL E	Gray	576	84 in.	10
280740	VFUVOL-87 DXL E	Black	580	18 in.	10	280806	VFUVOL-87 DXL E	Gray	576	96 in.	10
280741	VFUVOL-87 DXL E	Black	580	22 in.	10	280810	VFUVOL-87 DXL E	Gray	576	110 in.	10
280742	VFUVOL-87 DXL E	Black	580	24 in.	10						
280744	VFUVOL-87 DXL E	Black	580	30 in.	10						
280746	VFUVOL-87 DXL E	Black	580	36 in.	10						
280748	VFUVOL-87 DXL E	Black	580	40 in.	10						

YKK® and Vislon® are registered trademarks of YKK Corporation. Delrin® is a registered trademark of E.I. Dupont de Nemours and Company, Inc.



No. 280446

YKK® VISLON® VFUVOL107TX NO. 10 SEPARATING ZIPPER WITH AUTOMATIC LOCK – DOUBLE-PULL PLASTIC SLIDER

YKK No. 10 Vislon Separating Zippers are extremely strong and lightweight and differ from conventional zippers, because the “teeth” are made from Delrin® and the tape is polyester. Because of the unique properties of the Vislon Zipper, it has a wide variety of industrial, consumer and military applications where environmental conditions reduce the effectiveness of metal zippers.

The Vislon Zipper is corrosion resistant. The zipper is self-lubricating and operates smoothly despite mud, sand, etc. The color is an integral part of the molding material, creating a finish that does not rub off, peel or chip.

ITEM #	STYLE #	COLOR	COLOR NUMBER	LENGTH	STANDARD PACKAGE
280218	VFUVOL107TX	White	501	18 in.	10
280220	VFUVOL107TX	White	501	24 in.	10
280221	VFUVOL107TX	White	501	30 in.	10
280222	VFUVOL107TX	White	501	36 in.	10
280224	VFUVOL107TX	White	501	40 in.	10
280226	VFUVOL107TX	White	501	42 in.	10
280228	VFUVOL107TX	White	501	48 in.	10
280230	VFUVOL107TX	White	501	54 in.	10
280232	VFUVOL107TX	White	501	60 in.	10
280234	VFUVOL107TX	White	501	66 in.	10
280236	VFUVOL107TX	White	501	72 in.	10
280237	VFUVOL107TX	White	501	78 in.	10
280238	VFUVOL107TX	White	501	84 in.	10
280240	VFUVOL107TX	White	501	96 in.	10
280242	VFUVOL107TX	White	501	100 in.	10
280244	VFUVOL107TX	White	501	108 in.	10
280246	VFUVOL107TX	White	501	110 in.	10
280248	VFUVOL107TX	White	501	120 in.	10
280418	VFUVOL107TX	Black	580	18 in.	10
280420	VFUVOL107TX	Black	580	24 in.	10
280421	VFUVOL107TX	Black	580	30 in.	10
280422	VFUVOL107TX	Black	580	36 in.	10
280424	VFUVOL107TX	Black	580	40 in.	10
280426	VFUVOL107TX	Black	580	42 in.	10
280428	VFUVOL107TX	Black	580	48 in.	10
280430	VFUVOL107TX	Black	580	54 in.	10
280432	VFUVOL107TX	Black	580	60 in.	10
280434	VFUVOL107TX	Black	580	66 in.	10
280436	VFUVOL107TX	Black	580	72 in.	10
280438	VFUVOL107TX	Black	580	84 in.	10
280440	VFUVOL107TX	Black	580	96 in.	10
280442	VFUVOL107TX	Black	580	100 in.	10
280444	VFUVOL107TX	Black	580	108 in.	10
280446	VFUVOL107TX	Black	580	110 in.	10
280448	VFUVOL107TX	Black	580	120 in.	10

YKK® and Vislon® are registered trademarks of YKK Corporation. Delrin® is a registered trademark of E.I. Dupont de Nemours and Company, Inc.



No. 295685

YKK® VISLON® VSOL56 NO. 5 SEPARATING ZIPPER WITH AUTOMATIC LOCK – SHORT SINGLE PULL METAL SLIDER

YKK No. 5 Vislon Separating Zippers are extremely strong and lightweight and differ from conventional zippers, because the “teeth” are made from Delrin® and the tape is polyester. Because of the unique properties of the Vislon Zipper, it has a wide variety of industrial, consumer and military applications where environmental conditions reduce the effectiveness of metal zippers.

The Vislon Zipper is corrosion resistant. The zipper is self-lubricating and operates smoothly despite mud, sand, etc. The color is an integral part of the molding material, creating a finish that does not rub off, peel or chip.

ITEM #	STYLE #	COLOR	COLOR NUMBER	LENGTH	STANDARD PACKAGE
295685	VSOL56	Black	580	52 in.	10
295687	VSOL56	White	501	46 in.	10
295690	VSOL56	White	501	12 in.	10
295692	VSOL56	White	501	24 in.	10
295693	VSOL56	White	501	30 in.	10
295694	VSOL56	White	501	36 in.	10
295695	VSOL56	White	501	42 in.	10
295697	VSOL56	White	501	48 in.	10
295698	VSOL56	White	501	54 in.	10
295699	VSOL56	White	501	60 in.	10
295701	VSOL56	White	501	72 in.	10
295703	VSOL56	White	501	84 in.	10
295705	VSOL56	White	501	96 in.	10
295707	VSOL56	White	501	108 in.	10
295709	VSOL56	White	501	144 in.	10
295711	VSOL56	Black	580	12 in.	10
295713	VSOL56	Black	580	24 in.	10
295714	VSOL56	Black	580	30 in.	10
295715	VSOL56	Black	580	36 in.	10
295716	VSOL56	Black	580	42 in.	10
295717	VSOL56	Black	580	44 in.	10
295718	VSOL56	Black	580	48 in.	10
295719	VSOL56	Black	580	54 in.	10
295720	VSOL56	Black	580	60 in.	10
295722	VSOL56	Black	580	72 in.	10
295724	VSOL56	Black	580	84 in.	10
295726	VSOL56	Black	580	96 in.	10
295728	VSOL56	Black	580	108 in.	10
295730	VSOL56	Black	580	144 in.	10
295733	VSOL56	Black	580	110 in.	10
295745	VSOL56	Black	580	46 in.	10

YKK® and Vislon® are registered trademarks of YKK Corporation. Delrin® is a registered trademark of E.I. DuPont de Nemours and Company, Inc.

YKK® VISLON® VFUVOL-86 DA E 5/8 NO. 8 SEPARATING ZIPPER WITH AUTOMATIC LOCK – SINGLE PULL METAL SLIDER

ITEM #	STYLE #	COLOR	LENGTH	STANDARD PACKAGE
280085	VFUVOL86 DA E 5/8	Black	60 in.	10

YKK® and Vislon® are registered trademarks of YKK Corporation.

YKK® ZIPLON® CFOR-106 DA E NO. 10 SEPARATING ZIPPER WITH AUTOMATIC LOCK – SINGLE PULL METAL SLIDER

ITEM #	STYLE #	COLOR	COLOR NUMBER	LENGTH	STANDARD PACKAGE
295766	CFOR-106 DA E	White	501	36 in.	10
295767	CFOR-106 DA E	Black	580	36 in.	10
295768	CFOR-106 DA E	White	501	48 in.	10
295769	CFOR-106 DA E	Black	580	48 in.	10
295770	CFOR-106 DA E	White	501	60 in.	10
295771	CFOR-106 DA E	Black	580	60 in.	10
295772	CFOR-106 DA E	White	501	72 in.	10
295773	CFOR-106 DA E	Black	580	72 in.	10
295774	CFOR-106 DA E	White	501	84 in.	10
295775	CFOR-106 DA E	Black	580	84 in.	10
295776	CFOR-106 DA E	White	501	96 in.	10
295777	CFOR-106 DA E	Black	580	96 in.	10
295778	CFOR-106 DA E	White	501	108 in.	10
295779	CFOR-106 DA E	Black	580	108 in.	10

YKK® and Ziplon® are registered trademarks of YKK Corporation. Delrin® is a registered trademark of E.I. DuPont de Nemours and Company, Inc.

YKK® ZIPLON® CFOR-105 DWL NO. 10 SEPARATING ZIPPER NON-LOCKING – DOUBLE PULL METAL SLIDER

ITEM #	STYLE #	COLOR	COLOR NUMBER	LENGTH	STANDARD PACKAGE
295960	CFOR-105 DWL E	White	501	36 in.	10
295961	CFOR-105 DWL E	Black	580	36 in.	10
295962	CFOR-105 DWL E	White	501	48 in.	10
295963	CFOR-105 DWL E	Black	580	48 in.	10
295964	CFOR-105 DWL E	White	501	60 in.	10
295965	CFOR-105 DWL E	Black	580	60 in.	10
295966	CFOR-105 DWL E	White	501	72 in.	10
295967	CFOR-105 DWL E	Black	580	72 in.	10
295968	CFOR-105 DWL E	White	501	84 in.	10
295969	CFOR-105 DWL E	Black	580	84 in.	10
295970	CFOR-105 DWL E	White	501	96 in.	10
295971	CFOR-105 DWL E	Black	580	96 in.	10
295972	CFOR-105 DWL E	White	501	108 in.	10
295973	CFOR-105 DWL E	Black	580	108 in.	10

YKK® and Ziplon® are registered trademarks of YKK Corporation.



No. 279813

YKK® ZIPPY COOL®

This two-part product includes a cleaner and lubricant. It is specially formulated for use on all types of metal and plastic zippers. Zippy Cool's patented push/pull dispenser brush removes harmful dirt, sand and salt. After rinsing, it leaves a protective film on the zipper. Lubrication on the zipper will not flake or cause jams, even in extreme temperatures. It contains no silicone or paraffin.

ITEM #	DESCRIPTION	STANDARD PACKAGE
279813	Zippy Cleaner and Lubricant	1

YKK® and Zippy Cool® are registered trademarks of YKK Corporation.



No. 279800

ZIPZAP LUBRICANTS

Extends the life of the zipper. Cleans and lubricates plastic, nylon, and metal zippers, without collecting dirt, sand or organic residue. The wax provides smooth zipper teeth operation, and the fluid cleans and lubricates the zipper action.

ITEM #	DESCRIPTION	PUT UP	STANDARD PACKAGE
279800	Fluid	2 oz.	24



No. 202475

AWL – AUTOMATIC

The No. 413 Automatic Awl is used for sewing leather and canvas. This tool carries a spool of thread on the handle and includes an extra curved needle and wrench.

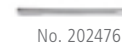

No. 202476

ITEM #	STYLE #	DESCRIPTION	STANDARD PACKAGE
202475	413	Automatic Awl	1
202476	413N-5	Automatic Awl Straight Needles	12



No. 202469

AWL – HEAVY-DUTY SCRATCH NO. 4

Scratch Awl comes with a plastic handle and quality steel blade. It's used to mark surfaces for cutting and fabrication and for holding down fabric while working.

ITEM #	STYLE #	BLADE SIZE	STANDARD PACKAGE
202469	1	2-1/2 in.	1
202470	2	3-1/2 in.	1



No. 248232

BINDER

This inexpensive universal binder attachment is ideal for use with 3/4 inch and 1 inch acrylic bindings. It comes with a universal plate assembly so it fits almost any commercial sewing machine. The opening is wide enough so that two edge turn bias cut binding slides smoothly and effortlessly through the attachment.

ITEM #	STYLE #	DESCRIPTION	SIZE	TYPE
248231	100LS	Universal Binder with Plate	3/4 in.	Plain
248232	100LS	Universal Binder with Plate	1 in.	Plain
248233	100LS	Universal Binder with Plate	5/8 in.	Plain



No. 275441

DRILLSTEADY DRILL FOR STAINLESS TUBING

DrillSteady uses 9/64 inch drill bit for No. 8 screw or fastener. Unique design allows drilling on installed frames, corners, or anywhere.

ITEM #	STYLE #
275441	3587



No. 275438

CRIMPING TOOL

Used for setting insert fittings in 3/4 inch and 7/8 inch O.D. aluminum tubing.

ITEM #	STYLE #	DESCRIPTION	STANDARD PACKAGE
275438	5583	Crimping Tool	1
275439	5585	Crimping Tool Replacement Tip	1



No. 216110



No. 216133



No. 216134

DOT® SNAPMASTER M840

The M840 hand press incorporates many features of bench and foot presses in a portable and cost-effective tool. Ideal for installing DOT® Durable™, Pull-The-Dot®, Lift-The-Dot® and curtain fasteners. Replacement parts available.

ITEM #	STYLE #	DESCRIPTION	FOR USE WITH
216110		Snapmaster Hand Press M840	
216115	4101	Cutting Punch	16205 DOT Lift-The-Dot Socket
216116	4201	Setting Punch	16506 DOT Lift-The-Dot Clinch Plate
216117	4301	Setting Punch	16205 DOT Lift-The-Dot Socket
216118	4401	Setting Die	16506 DOT Lift-The-Dot Clinch Plate
216124	4302	Setting Punch	78403 Curtain Fastener Eyelet
216125	4402	Setting Die	78505 Curtain Fastener Washer
216129	4303	Setting Punch	10224 DOT Durable Socket
216130	4403	Setting Die	10127/10128 DOT Durable Button
216131	4304	Setting Punch	10370 DOT Durable Stud
216132	4404	Setting Die	10412 DOT Durable Eyelet
216133	4103	Setting Punch	78403 Curtain Fastener Eyelet
216134	4203	Setting Die	78403 Curtain Fastener Eyelet
216135	4305	Setting Punch	18201 DOT Pull-The-Dot Socket
216136	4405	Setting Die Cap	18100 DOT Pull-The-Dot Button
216137	4700	Setting Punch	00900 #1 Grommet
216138	4701	Setting Die	00800 #1 Grommet
275113	9053	Punch Tool	
275114	9054	Die Tool	
275117	9063	Punch Tool	
275118	9064	Die Tool	

DOT®, Lift-The-Dot® and Pull-The-Dot® are registered trademarks of Scovill, Inc. Durable™ is a trademark of Scovill, Inc.



No. 216045



No. 216047

HAND TOOLS FOR DOT® COMMON SENSE® FASTENERS

ITEM #	STYLE #	DESCRIPTION
216045	C4-450	Common Sense Fastener Cutter
216047*	QTTL	Common Sense Quick Turn Lock Driver
216048*	QTTL-N	Common Sense Quick Turn Lock Driver
216050*	89-450	Common Sense Fastener Cutter
223508	9577	Common Sense Machine Die
223509	9578	Common Sense Machine Die
275442		E-Z Common Sense Hand Punch
275584	9908	Screwdriver for Curtain Fastener
275612		Fast Set Hand Tool for Curtain Fastener

*216047 - For use with 1/4 in. cordless screw driver or drill motor. To install XX-78315, XX-78324, XX-78325, X8-78324, XB-78324, XB-78325, turn buttons.

*216048 - For use with 1/4 in. cordless screw driver or drill motor. To install 404, 405, XB-404 and XB-405 turn buttons.

*216050 - Use with cutting pad (Item no. 223449). For BS-78403 (No. 400) Eyelet.

DOT® and Common Sense® are registered trademarks of Scovill, Inc.

HAND TOOLS FOR DOT® DURABLE™ OR GLOVE BUTTON FASTENERS



No. 223503



No. 275504



No. 275564

ITEM #	STYLE #	DESCRIPTION
223503	9936	Bench Die for BS-10412 Eyelet
248160*	164H	Hand Punch
275504*	169N	Phillips Head Screwdriver for Durable DOT
275507	9772	Setting Die for Baby Durable 12302/12303
275564	164	Setting Punch for Durable DOT
275583	1482	Die for Baby Durable 12105 Cap
275587	1488	Die for Baby Durable 12404/12405/12407 Post
275588	9323	Punch for Baby Durable 12205/12206 Socket
275589	9332	Punch for Baby Durable Eyelets
275592	ADAPPHIL	Phillips Screw Stud Adapter

*248160 - Works with #248175 and #248176.
 *275504 - For X8-10301, X8-10302, XX-10362, X8-10393, XB-10393, X8-10704, XX-10708 and X8-10934 studs.

DOT® is a registered trademark of Scovill, Inc. Durable™ is a trademark of Scovill, Inc.



No. 256071

HAND PRESS NO. M-380E

Hand press for DOT® fasteners.

ITEM #	STYLE #
256071	M-380E

DOT® is a registered trademark of Scovill, Inc.

HAND PRESS NO. M-380E – DIES FOR DOT® DURABLE™ FASTENERS



No. 223510



No. 223512

ITEM #	STYLE #	FOR USE WITH
223501	1401	X2-10128/X2-10127 Button
223510	1410	XB-10224 Socket
223512	1412	BS-10370 Stud
275580	9557	XB-10342 Stud

DOT® is a registered trademark of Scovill, Inc. Durable™ is a trademark of Scovill, Inc.

HAND TOOLS FOR DOT® LIFT-THE-DOT® FASTENERS



No. 248161



No. 275443



No. 275501



No. 275502

ITEM #	STYLE #	DESCRIPTION
248161	L6-9951	Lift-The-Dot Hand Punch
248162*	71-177	Lift-The-Dot Cutting Punch
275443		E-Z Lift-The-Dot Hand Cutting Punch
275480	16501	Die for BS-16501
275481	16349	Die for BS-16349
275501*	9951	Hand Cutting Punch for XX-16205/XX-16206
275502	169B	Screwdriver for Lift-The-Dot Studs
275573	9940	Bench Die for XB-16358 Single Eyelet
275575*	171	Hand Punch for BS-78332/BS-78333/BS-16349
275576	9432	Die for 90-16506

*248162 - For 90-16349, 91-78322 and 91-78333.
 *275501 - Use with cutting pad (Item no. 223449). For XX-16205 socket with chisel point.
 *275575 - Use with cutting pad (Item no. 223449).

DOT® and Lift-The-Dot® are registered trademarks of Scovill, Inc.

HAND PRESS NO. M-380E – DIES FOR DOT® LIFT-THE-DOT® FASTENERS

ITEM #	STYLE #	DESCRIPTION	FOR USE WITH
223554	1454	Die	XX-16205 socket
223555	1455	Die	BS-16506 clinch plate
223556	1456	Die	XB-16358/XB-16359 stud
223557	1457	Die	BS-16509 washer

FABRIC FASTENER KIT



No. 248133

Used for setting 10128, 10224, 10370 and 10412 DOT® Durable™ fasteners.

ITEM #	STYLE #	DESCRIPTION
248133	USC1T	Nos. 9896 and 9897 setting tools (2 pieces each bag)

DOT® is a registered trademark of Scovill, Inc. Durable™ is a trademark of Scovill, Inc.

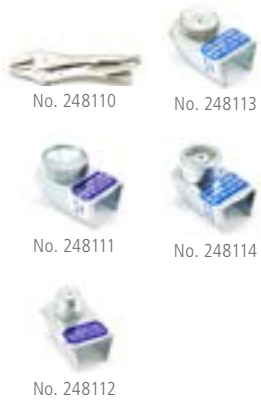

PLIERS – VISE® PLIERS KIT FOR DOT® DURABLE™

ITEM #	STYLE #	DESCRIPTION	FOR USE WITH
248109*		VISE Pliers and Dies Kit	
248110	T310R	VISE Pliers	
248111	MT479B	Metal Anvil Die	X2-10128 Button #MT479B
248112	MT482A	Metal Clincher Die	XB-10224 Socket #MT482B
248113	MT480B	Metal Anvil Die	BS-10412 Eyelet #MT480B
248114	MT489A	Metal Clincher Die	BS-10370 Stud #MT489A

*248109 - Kit includes: 2– No. 100 VISE Pliers; 1– No. M-102 Metal Clincher Die for No. XB-10224 Socket; 1– No. M-103 Metal Anvil Die for No. BS-10412 Eyelet; 1– No. M-104 Metal Clincher Die for No. BS-10370 Stud; 1– No. M-105 Metal Anvil Die, with Ring, for X2-10128 Button.

VISE® is a registered trademark of Irwin Tools. DOT® is a registered trademark of Scovill, Inc. Durable™ is a trademark of Scovill, Inc.



PRES-N-SNAP®

ITEM #	DESCRIPTION	FOR USE WITH
248172	Rubber O-Ring	#12 Stud Black
275397	Die	#10379 Stud
275398	Bench Mount	
275399	Frame	
275400*	Pres-N-Snap Complete Tool	
275401	Die	#10128 Button
275402	Die	#10370 Stud
275403	Die	#10412 Eyelet
275404	Die	#10224 Socket
275405	M-2700 Rubber Ring	DOT Durable Dies
275409	Rubber O-Ring	
275411	Baby Durable Die Set	
275412	Die	#BS16509 Washer
275413	Die	#XB16358 Stud
275415	Plunger	
275416	Spring	
275417	Handle	
275423	Stayput Shock Cord Clip (SCC/SCR)	
275427	Lever	
275428	Die	#10342 Gypsy Stud
275429	Die Set	DOT Speedy Rivet #11L-Small HPR/HPRF

*275400 - Includes dies for 10128, 10224, 10370, 10412 durable fasteners – plus die for No. 1 grommet with plain washer.

Pres-N-Snap® is a registered trademark of Hoover Products. DOT® is a registered trademark of Scovill, Inc. Durable™ is a trademark of Scovill, Inc.



No. 275420



No. 275425

PRES-N-SNAP® – GROMMET DIES

ITEM #	DESCRIPTION	FOR USE WITH
248173	Die Set	No. 0 Grommets with Spur Washers
248174	Hole Punch	No. 0 Grommets
275419	Die Set	No. 1 Plain Grommets
275420	Die Set	No. 2 Plain Grommets
275421	Die Set	No. 00 Plain Grommets
275422	Die Set	No. 0 Plain Grommets
275425	Hole Punch	No. 1 Grommets
275426	Hole Punch	No. 2 Grommets
275430	Die Set	No. 2 Self-Piercing Grommets
275431	Die Set	No. 1 Self-Piercing Grommets
275432	Die Set	No. 1 Grommets with Spur Washers
275434	Die Set	No. 0 Self-Piercing Grommets
275435	Hole Punch	No. 00 Grommets

Pres-N-Snap® is a registered trademark of Hoover Products.



No. 275590



No. 275595



No. 275596

QUICK-FIT™ TOOL KIT

Quick-Fit holding tool snaps on to existing studs and provides a quick and easy way to hold material while fitting — no clamps necessary. Quick-Fit holds material in place on the holding pin, especially on a windy day. Quick-Fit release tool easily installs and removes the holding pin from the stud. Quick-Fit tools are great for fitting with material and also holding paper or plastic when making a pattern. Can be used over and over on job after job. Can be used on boat cockpit covers, side curtains, enclosures, console covers, carpet, pickup truck tonneau covers, etc. Quick-Fit holding tools accurately mark the fabric cover where the snap sockets are to be placed.

Quick-Fit Tool Kit includes 25 Quick-Fit Caps, 50 Quick-Fit Sockets and 1 Quick-Fit Release Tool.

ITEM #	DESCRIPTION
275590	Quick-Fit Fastener Tool Kit
275591	Quick-Fit Fastener Tool Kit Caps
275595	Quick-Fit Fastener Tool Kit Sockets with Points
275596	Quick-Fit Fastener Release Tool

Quick-Fit™ is a trademark of Quick Fit Canvas Tools.



FASNAP® PM5 GROMMET MACHINE

The PM5 machine is an industry standard bench-mounted machine. It is made of tough ductile iron and has a deep throat with a longer padded handle. This machine uses standard 3/8 inch diameter shank dies that set self-piercing grommets up to size 300 (#4), and snap fasteners in one motion, swiftly and efficiently. Throat depth: 4-3/4 inch.

ITEM #	DESCRIPTION
248185	Fasnap PM5 Grommet Machine

FASNAP® is a registered trademark of The FASNAP Corporation.



No. 256430

HOLE PUNCH

Excellent for punching screw holes in aluminum molding, without leaving burred edges.

Makes a 1/8 inch or 3/16 inch hole and are easily changed from standard 1/8 inch hole size to 3/16 inch. Punch is constructed from high-quality tool steel used in commercial high-production punch press dies. Body is lightweight, die cast aluminum with rust-resistant, nickel-plated steel handles and parts. Features a non-slip cushion handle grip.

ITEM #	STYLE #	SIZE
256430	HP18K	1/8 in. to 3/16 in. holes



No. 248501



No. 248502



No. 248506

ENGEL HOT KNIFE

Cuts and seals the edges of synthetic fabrics to prevent fraying. The knife can be used with a cutting foot to eliminate the need for a special cutting base or surface. Designed for intermittent operation, the knife heats up in six to eight seconds. Temperature is controlled by a convenient trigger switch. All items are sold separately.

Use in well ventilated areas.

ITEM #	STYLE #	DESCRIPTION
248501	C851	Engel HSG-O Electric Hot Knife Cutter
248502	C852	Engel Hot Knife Blade 100R
248506	C856	Engel Hot Knife Cutting Foot



No. 252248

HAND NOTCHER

Fast and easy cutting. Notcher makes a clean 30°, “V”-shaped cut in sheet metal. 13/16 inch maximum throat depth. Upper cutting jaw is drop forged, high-impact alloy steel. Hook design of cutting jaw facilitates notching to desired depth without slippage. Nickel plated and black oxide finish. Blue grips.

ITEM #	STYLE #	LENGTH	WEIGHT
252248	N1	8 in.	1 lb.



No. 256094

MULTI-DUTY HAND PRESS NO. W-1

This Osborne high quality hand machine cuts fabric and covers buttons. It uses 2 piece dies and short cutters. This hand machine has a reinforced frame and handle. It bolts to a table for added stability. The machine handles between 80-120 buttons per hour. It can also be used to set snaps, grommets and ventilators.



No. 256095

ITEM #	STYLE #	DESCRIPTION
256094	W-1	Osborne Multi-Duty Hand Press #W-1
256095	W-1H	Handle
256096	W-1P	Pin
256097	W-1PL	Plate
256098	W-1 SPRING	Top Spring



No. 256098

MULTI-DUTY HAND PRESS NO. W-1 – DIES

Dies for setting snaps, grommets, and ventilators for the Osborne Multi-Duty Hand Press #W-1 (Item# 256094).

ITEM #	STYLE #	DESCRIPTION	SIZE
256297	WDISN41	Snap Die #24	24
256298	WDISN201	Snap Die #20	20
256299	WDIGRC00	Setting Die #00 For Plain Washer	00
256300	WDIGRC0	Setting Die #0 For Plain Washer	0
256301	WDIGRC1	Setting Die #1 For Plain Washer	1
256302	WDIGRC2	Setting Die #2 For Plain Washer	2
256303	WDIGRC3	Setting Die #3 For Plain Washer	3
256304	WDIGRC4	Setting Die #4 For Plain Washer	4
256305	WDIGRC5	Setting Die #5 For Plain Washer	5
256306	WDIGRC6	Setting Die #6 For Plain Washer	6
256312	WDIGRC12	Setting Die #12 For Plain Washer	12
256315	WDIGRC15	Setting Die #15 For Plain Washer	15
256320	WDISGRC0	Setting Die #0 for Spur Washer	0
256321	WDISGRC1	Setting Die #1 for Spur Washer	1
256322	WDISGRC2	Setting Die #2 for Spur Washer	2
256323	WDISGRC3	Setting Die #3 for Spur Washer	3
256324	WDISGRC4	Setting Die #4 for Spur Washer	4
256325	WDISGRC5	Setting Die #5 for Spur Washer	5
256330	WDISGRC10	Setting Die #10 for Spur Washer	10
256331	WDIV1	Ventilator Die 1 in.	
256332	V-1-1	Ventilator 1 in.	
256333	WDIVS	Ventilator Die 3/4 in.	
256334	684	Ventilator 3/4 in.	



No. 255250

PLIERS – FABRIC PULLING PLIERS NO. 250

No. 250 plier is made with a hammer jaw. The hammer acts as a lever if a strong pull is required. This is an excellent tool for stretching canvas and leather as well as webbing. It is ideal for pulling fabric over frames.

ITEM #	STYLE #	LENGTH	STANDARD PACKAGE
255250	250	8-3/4 in.	1



No. 256440

REVOLVING PUNCH NO. 155

Used to punch holes in soft fabrics and leather goods. The frame is made of highly polished forged steel. The cutting tubes are hand turned from high carbon tool steel and threaded to allow easy replacement.

ITEM #	STYLE #	LENGTH	STANDARD PACKAGE	WEIGHT
256440	155	8-1/2 in.	1	1 lb.



No. 256452

REVOLVING PUNCH NO. 155 – CUTTING TUBE KIT

ITEM #	STYLE #	STANDARD PACKAGE
256452	155T	1



No. 256442

REVOLVING PUNCH NO. 155 – CUTTING TUBES

ITEM #	STYLE #	SIZE	STANDARD PACKAGE
256441	155T-1	3/32 in.	1
256442	155T-2	7/64 in.	1
256443	155T-3	1/8 in.	1
256444	155T-4	5/32 in.	1
256445	155T-5	11/64 in.	1
256446	155T-6	3/16 in.	1



No. 256440

REVOLVING PUNCH NO. 155 – PUNCH ANVIL

A copper replacement base for the No. 155 Revolving Punch. The soft copper composition of this base is gentle on dies to provide longer service life.

ITEM #	STYLE #	STANDARD PACKAGE
256448	155A	12



No. 268120

SEWING KIT

Exclusively from Trivantage®, our Sewing Kit puts sewing solutions right at your fingertips. This durable and useful kit can be used on a variety of fabrics and projects. The kit contains:

- 1 small curved scissor – Makes working on sewing machine threads much easier.
- 1 bent scissor – Great for cutting small threads and material that is close to a sewing machine needle.
- 1 solid ball seam ripper – This heavy-duty alternative to plastic seam rippers is primarily used for window replacements.
- 1 staple remover – Removes staples from fabric or upholstery easily and without pulls. Each tool is made from handcrafted stainless steel.

ITEM #
268120

Trivantage® is a registered trademark of Glen Raven, Inc.



No. 214301

THREAD NIPPERS

ITEM #	FULL LENGTH
214301	4-1/2 in.



No. 248395

SCISSORS – OLFA® SERRATED EDGE SCISSORS

OLFA stainless steel scissors are ideal for consumer and industrial applications. High quality stainless steel blades meet perfectly for precision cutting. The material being cut is held in place by one blade which is slightly serrated providing maximum control. Excellent for cutting multiple layers of fabric.

ITEM #	STYLE #	STANDARD PACKAGE
248395	SCS-2	1

OLFA® is a registered trademark of the OLFA Corporation.



No. 266225

SHEARS – WISS® UPHOLSTERY, CARPET AND FABRIC SHEARS

Hot drop-forged, polished blades. One blade is ground to a knife-edge.

To attain the extra sharp knife edge, the cutting edge of the top blade is ground to a greater angle than regular shears. For this reason they will require more frequent sharpening than conventional Wiss Inlaid® Trimmers. However, a simple resharpening procedure will restore the edge quickly and easily. Do not stone the inside of this blade or the opposing blade.

ITEM #	STYLE #	FULL LENGTH	LENGTH OF CUT	STANDARD PACKAGE
266225	1225	10-1/4 in.	4-3/4 in.	1
266226	1226	12-1/4 in.	6-1/8 in.	1

Wiss® and Inlaid® are registered trademarks of Cooper Industries, Inc.



No. 266022

SHEARS – WISS® UPHOLSTERY, DRAPERY, CARPET AND FABRIC SHEARS – HEAVY DUTY

With thick, heavy-duty blades to cut through multiple layers and tough material. Hot drop-forged, polished standard edge blades.

To attain the extra sharp knife edge, the cutting edge of the top blade is ground to a greater angle than regular shears. For this reason they will require more frequent sharpening than conventional Wiss Inlaid® Trimmers. However, a simple resharpening procedure will restore the edge quickly and easily. Do not stone the inside of this blade or the opposing blade.

ITEM #	STYLE #	FULL LENGTH	LENGTH OF CUT	STANDARD PACKAGE
266019	20W	10-1/4 in.	4-3/4 in.	1
266022	22W	12-1/4 in.	6-1/8 in.	1

Wiss® and Inlaid® are registered trademarks of Cooper Industries, Inc.

SHEARS – ERGONOMIC SHEARS

Ergonomic Shears have an extended bottom ring that allows you to use all four fingers and wear a glove, if needed. By using your whole hand, you have more comfort, less strain on the wrist and added cutting leverage. This bent trimmer is made from high-carbon steel with a knife edge and blue soft-coated handle for extra comfort. A chrome-over-nickel plating inside and out provides double rust prevention.



No. 266227

ITEM #	STYLE #	FULL LENGTH
266227	210LRK	10 in.



No. 266027

SHEARS – WISS® INDUSTRIAL SHEARS

Hot drop-forged, nickel-plated shears with standard edge blades.

To attain the extra sharp knife edge, the cutting edge of the top blade is ground to a greater angle than regular shears. For this reason they will require more frequent sharpening than conventional Wiss Inlaid® Trimmers. However, a simple resharpening procedure will restore the edge quickly and easily. Do not stone the inside of this blade or the opposing blade.

ITEM #	STYLE #	FULL LENGTH	LENGTH OF CUT	STANDARD PACKAGE
266027	27	7-1/2 in.	3-1/8 in.	1
266028	28	8-1/8 in.	3-3/4 in.	1

Wiss® and Inlaid® are registered trademarks of Cooper Industries, Inc.



No. 266020

SHEARS – WISS® INDUSTRIAL SHEARS – HEAVY DUTY

Hot drop-forged, polished standard edge blades, with black handles. Style 20 LH is the left-handed version.

To attain the extra sharp knife edge, the cutting edge of the top blade is ground to a greater angle than regular shears. For this reason they will require more frequent sharpening than conventional Wiss Inlaid® Trimmers. However, a simple resharpening procedure will restore the edge quickly and easily. Do not stone the inside of this blade or the opposing blade.

ITEM #	STYLE #	FULL LENGTH	LENGTH OF CUT	STANDARD PACKAGE
266020	20	10-1/4 in.	4-3/4 in.	1
266021	20LH	10-1/4 in.	4-3/4 in.	1

Wiss® and Inlaid® are registered trademarks of Cooper Industries, Inc.



No. 266016

SHEARS – WISS® SHOP SHEARS

Serrated bladed shears.

ITEM #	STYLE #	FULL LENGTH	STANDARD PACKAGE
266016	W912	10 in.	1

Wiss® is a registered trademark of Cooper Industries, Inc.



No. 266231

SHEARS – KRETZER®

Kretzer Scissors is the leading German scissors manufacturer. The quality and durability of these shears are only two of many aspects associated with German craftsmanship.

ITEM #	STYLE #	DESCRIPTION	FULL LENGTH	STANDARD PACKAGE
266231	64420	Trivantage® Pinking Shears	8 in.	1
266232	73725	Trivantage Shop Shears	10 in.	1
266233	K22	Trim Shears	12 in.	1
266234	K20	Trim Shears	10 in.	1
266236	72020	Trivantage Trim Shears	8 in.	1

Kretzer® is a registered trademark of Johann Kretzer GmbH & Co. Trivantage® is a registered trademark of Glen Raven, Inc.



No. 268100

STAPLE REMOVER

Forged from 4140 alloy tempered steel.

ITEM #	STYLE #
268100	124



No. 275599

TOP-SNAPPER®

Built of marine-grade stainless steel with an easy to grip rubberized handle, makes snapping your canvas boat top into place easy and convenient. Just slide the ingenious, patented Top-Snapper over the snap, pull it into place, and snap it shut.

ITEM #	STYLE #
275599	008.1



Top-Snapper® is a registered trademark of Ironwood Pacific Inc.



No. 248219



No. 248221

CUTTER – TUBING

Excellent portable tubing cutter for aluminum. Stainless steel cutting wheel sold separately.

ITEM #	STYLE #	DESCRIPTION
248219	TC312	Tube Cutter
248221	75046	Stainless Steel Cutting Wheel



No. 216400

CUTTER – SIDE CUTTER

Typically used for plain and tooth grommet washers. For best results use Trivantage® Cutting Pad (Item no. 223449). Do not use with steel head hammers.

ITEM #	STYLE #	SIZE HOLE
216400	00	3/16 in.
216401	0	1/4 in.
216402	1	9/32 in.
216403	2	3/8 in.
216404	3	7/16 in.
216405	4	1/2 in.
216406	5	5/8 in.
216407	6	3/4 in.
216408	7	7/8 in.
216409	8	1 in.

Trivantage® is a registered trademark of Glen Raven, Inc.



No. 216504

CUTTER – SPECIAL CUTTER

Typically used for rolled rim spur grommet washers. For best results use Trivantage® Cutting Pad (Item no. 223449). Do not use with steel head hammers.

ITEM #	STYLE #	SIZE HOLE
216499	00	3/16 in.
216501	0	1/4 in.
216502	1	9/32 in.
216503	2	3/8 in.
216504	3	7/16 in.
216505	4	1/2 in.
216506	5	5/8 in.
216507	6	3/4 in.
216508	7	7/8 in.
216509	8	1 in.

Trivantage® is a registered trademark of Glen Raven, Inc.



No. 223306

SETTING DIE FOR ROLLED RIM GROMMETS AND SPUR WASHERS

For inserting round grommets. Made of superior grade drop forged steel or hardened steel tool.

Setting Dies are guaranteed against defects in material and workmanship, but this guarantee is not intended to cover tools against wear, over-strain, steel hammering, etc. To obtain maximum life of tools use Dead Blow Hammer, Rawhide Mallet, Cutting Pad and strike at 90 degree angle.

ITEM #	STYLE #	DESCRIPTION
223301	0	Stimpson
223302	1	Stimpson
223303	2	Stimpson
223304	3	Stimpson
223305	4	Stimpson
223306	5	Stimpson
223307	6	Stimpson
223308	7	Stimpson
223309	8	Stimpson
223420	0	Osborne #217
223421	1	Osborne #217
223422	2	Osborne #217
223423	3	Osborne #217
223424	4	Osborne #217
223425	5	Osborne #217
223426	6	Osborne #217
223427	7	Osborne #217
223428	8	Osborne #217



No. 223205

SETTING DIE FOR PLAIN AND TOOTH GROMMETS AND WASHERS

For inserting round grommets. Made of superior grade drop forged steel or hardened steel tool.

Setting Dies are guaranteed against defects in material and workmanship, but this guarantee is not intended to cover tools against wear, over-strain, steel hammering, etc. To obtain maximum life of tools use Dead Blow Hammer, Rawhide Mallet, Cutting Pad and strike at 90 degree angle.

ITEM #	STYLE #	DESCRIPTION
223200	00	Stimpson
223201	0	Stimpson
223202	1	Stimpson
223203	2	Stimpson
223204	3	Stimpson
223205	4	Stimpson
223206	5	Stimpson
223207	6	Stimpson
223208	2J	Stimpson
223209	4	Stimpson
223410	00	Osborne #216
223411	0	Osborne #216
223412	1	Osborne #216
223413	2	Osborne #216
223414	3	Osborne #216
223415	4	Osborne #216
223416	5	Osborne #216
223417	6	Osborne #216



No. 216490

PUNCH KIT – SELF-CENTERING

This handy and versatile kit contains a threaded handle with self-centering pointed plunger. Designed to accommodate nine interchangeable threaded cutting tubes in diameter sizes of 1/4 inch, 5/16 inch, 3/8 inch, 7/16 inch, 1/2 inch, 5/8 inch, 3/4 inch, 7/8 inch and 1 inch. The punches in this set will cleanly cut fabric, leather, rubber, paper, plastic and other soft materials.

ITEM #	STYLE #
216490	K156



No. 248102

GROMMET KIT – HOME

A complete and inexpensive kit for household use. Each kit consists of a grommet die, a cutting punch, 3 dozen grommets and washers, a small cutting board and complete instructions.

ITEM #	STYLE #	GROMMET SIZE	WEIGHT
248100	0	1/4 in.	1-1/2 lbs.
248101	1	9/32 in.	1-1/2 lbs.
248102	2	3/8 in.	1/3/4 lbs.
248103	3	7/16 in.	1/3/4 lbs.
248104	4	1/2 in.	1/3/4 lbs.



No. 256004

FOOT PRESS – HAND FEED

The #479 is a hand feed cast iron machine, ideal where production is limited. Tools are quickly interchangeable.

The machine is 45 inches in height and requires a floor space of 14 inches x 20 inches. Weighs 113 pounds. It has a throat depth of 4 inches and a stroke of 1-3/8 inches.

ITEM #	STYLE #	DESCRIPTION	FOR USE WITH
223436	3	Setting Die	Brass Plain Washer
223437	2	Setting Die	Brass Plain Washer
223438	1	Setting Die	Brass Plain Washer
223439	1	Die Punch and Set	Brass Spur Washer
223446	2	Die Punch and Set	Brass Spur Washer
223447	1	Die Punch and Set	Brass Plain Washer
223451	1	Setting Die	Brass Spur Washer
223452	2	Setting Die	Brass Spur Washer
256004	479	Hand Feed Foot Press	



No. 237001

HAMMER – DEAD BLOW

Quick-change threaded faces are molded in one piece without metal plugs. Shot-filled heads reduce rebound and increase impact. Replacement faces in white nylon, medium red, extra hard yellow and tough brown polyurethane.

ITEM #	STYLE #	DESCRIPTION	COLOR	SIZE	WEIGHT
237000	DB175	Dead Blow Hammer		1-3/4 in.	2 lbs.
237001	DB250	Dead Blow Hammer		2-1/2 in.	4 lbs.
237002	175HF	Face Replacement	White	1-3/4 in.	
237003	250HF	Face Replacement	White	2-1/2 in.	
237004	175XF	Face Replacement	Yellow	1-3/4 in.	
237005	250TF	Face Replacement	Brown	2-1/2 in.	



No. 250801

MALLET – RAWHIDE

Commonly known as a "maul".

ITEM #	STYLE #	DESCRIPTION	WEIGHT
250800	393-2	Mallet	2 lbs.
250801	393-3	Mallet	2-12/ lbs.
250802	393-4	Mallet	4-1/2 lbs.
250803	393-6	Mallet	6 lbs.
250804		Mallet Handle	
250806	393-3RR	Mallet Leather Refill	
250807	393-4RR	Mallet Leather Refill	
250808	393-6RR	Mallet Leather Refill	
250809	196-2	Mallet	



No. 237015

HAMMER – RAWHIDE WITH SPLIT HEAD – NO. 395

Ideal for use with arch punches, grommet dies or wherever a cushioned blow is desired. No trouble to replace faces. Just loosen the safety nut, remove worn face, insert replacement and tighten.

ITEM #	STYLE #	DIAMETER OF FACE	SIZE	WEIGHT
237013	395-1	1-1/4 in.	1	1-1/2 lbs.
237014	395-2	1-1/2 in.	2	2 lbs.
237015	395-3	1-3/4 in.	3	3 lbs.

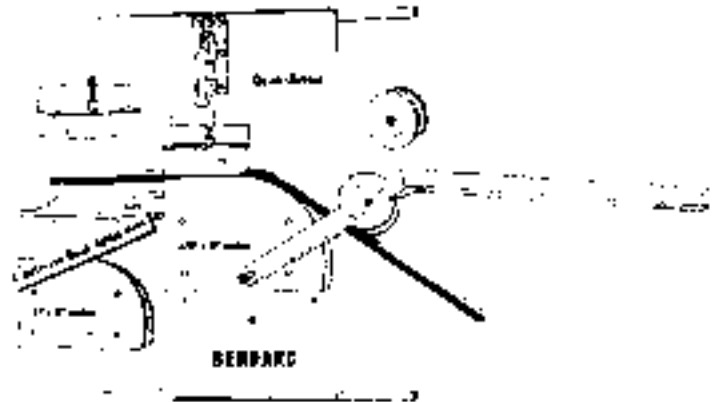

BENDARC QUICK-SWITCH BENDER

The Bendarc bends a 6, 8, 10 or 12 inch radius on either 7/8, 1, or 1-1/4 inch OD aluminum or stainless steel tubing. Designed for wall or bench mounting. Bends are formed using a long handle for leverage and with the aid of body weight. The Bendarc gives strong bends with smooth, rounded corners. Constructed of boiler plate steel with bearing supported roller. Rollers are high-density polymer for mar resistant contact with fine tubing finishes.

Interchangeable forming blocks, clamp blocks and rollers are also available to convert from a 6 inch radius to 8 inch or 10 inch, and a 7/8 inch OD tube to 1 inch OD. Switch sizes easily and quickly with only an Allen wrench and a 1/2 inch socket. Once forming block replacement is installed, only a finger tight adjustment of a nut on the clamp block is required.

Items are drop ship only.

ITEM #	DESCRIPTION	FOR	RADIUS
205304	Tube Bender	1 in. tubing	6 in.
205310	Tube Bender	7/8 in. tubing	6 in.
205313	Tube Bender	1-1/4 in. tubing	10 in.
205314	Tube Bender	7/8 in. tubing	8 in.
205315	Tube Bender	1 in. tubing	12 in.
205316	Tube Bender	1 in. tubing	8 in.
205318	Tube Bender	7/8 in. tubing	10 in.
205319	Tube Bender With Steel Encased Form Block	1 in. square tubing	12 in.
205320	Tube Bender	1 in. tubing	10 in.
205321	Tube Bender With Steel Encased Form Block	1 in. square tubing	10 in.
205330	Form Block	7/8 in. round tubing	6 in.
205332	Form Block	1 in. round tubing	6 in.
205334	Form Block	7/8 in. round tubing	8 in.
205336	Form Block	1 in. round tubing	8 in.
205337	Steel Encased Form Block	1 in. square tubing	10 in.
205338	Form Block	7/8 in. round tubing	10 in.
205340	Form Block	1 in. round tubing	10 in.
205341	Form Block	7/8 in. round tubing	12 in.
205342	Clamp Black Assembly	7/8 in. round tubing	
205343	Form Block	1 in. round tubing	12 in.
205344	Clamp Black Assembly	1 in. round tubing	
205345	Clamp Black Assembly	1 in. square tubing	
205346	Bearing Support Roller	7/8 in. round tubing	
205347	Bearing Support Roller	1-1/4 in. round tubing	
205348	Bearing Support Roller	1 in. round tubing	
205349	Bearing Support Roller	1 in. square tubing	
205350	Clamp		
205352	Pull Down Handle		



No. 237021

HAMMER – RAWHIDE REPLACEMENT HEADS

ITEM #	STYLE #	SIZE
237020	395F-1	1
237021	395F-2	2
237022	395F-3	3



No. 223449

CUTTING PAD

Made of a special formula resilient vinyl plastic, these tough cutting pads are ideal for use with Osborne Punches. They are long wearing and can be used on both sides. Use on a solid base for best results.

ITEM #	STYLE #	MATERIAL	SIZE
223449	603	Urethane	10 in. x 10 in. x 3/8 in.



No. 237016

HAMMER – TACK

Magnetic.

ITEM #	STYLE #	DESCRIPTION
237016	33	Magnetic Tack Hammer

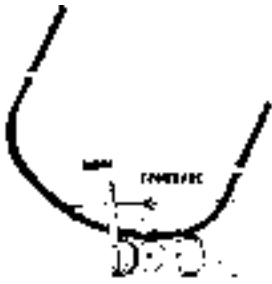

CROWNARC CROWN BENDER

Bends 7/8 inch, 1 inch and 1-1/4 inch outside diameter tubing using the same dies. The crown radius is adjustable from 30 in. minimum to infinity. The only Crownarc with gear drive; Crownarc's crank turns both lower wheels and "takes a bigger bite" to get more crown per pass. The Z wheel drive system makes control much easier. The back plate is boiler plate steel and rollers are high-density polymer for mar resistant contact with fine tubing. The center roller is fully adjustable.

The Crownarc is supplied with rollers cut for 1 inch diameter tubing. This easily crowns 1 inch and 7/8 inch stainless or aluminum tubing. Bender can be mounted on the wall, on a table or on the side or rear of a truck.

ITEM #	DESCRIPTION	FOR	RADIUS
205325	Tube Bender	7/8 in. and 1 in. tubing	
205327	Tube Bender	1 in. square tubing	
205329	Gear Mounted Roller	1 in. square tubing	1 in.
205362	Tube Bender	1-1/4 in. round tubing	



SPEC OVERLAP ACRYLIC WEDGE WELDER

Spec Wedge Welders were designed to provide operators with the benefits of Triad technology for single function convenience at an affordable price. With a Spec Welder, you can perform a specific welding function without changing out attachments. The Spec Overlap Acrylic Wedge Welder allows overlap welding on acrylic products, as well as other non-thermoplastic materials. Using Thermal Bonding Tape, you can produce flatter, waterproof seams.

Like other Wedge Welders, the Spec Welder features noiseless and smokeless operation, patented self-centering wedge and unique self-guiding track system for hands-free operation. The Spec also includes a new swing-out wedge feature for easy cleaning, service or inspection.

ITEM #	STYLE #	DESCRIPTION
999154	SW70300	Spec Overlap Acrylic Wedge Welder



TRIAD WEDGE ATTACHMENTS

5 Foot Track System w/Connector – A great labor saver, the pre-fabricated 5 foot track section is ideal for long runs, material handling and eliminating operator error. When using the Track, the operator does not have to steer the Triad welder. Simply position the material for proper overlap with the magnets provided, and let the Triad weld down the track. Acrylic Tape Attachment – Use with bonding tape to create various types of welds.

ITEM #	STYLE #	DESCRIPTION
999089	33-090	Triad Wedge Welder Acrylic Tape Attachment
999090	33-500	Triad Wedge Welder 5 ft. Track with Connector



No. 999065

SINCLAIR ERGO GRIP HOT AIR WELDER

For all your hand-held welding needs. Features ergonomic grip for comfort. Exclusive heat shield to help prevent burning. Variable temperature control to 650C degrees. Suitable for connection to a standard 110V AC electrical outlet.



No. 999067

ITEM #	Style #	DESCRIPTION
999065	42-0153SE	Ergo Grip Hot Air Welder with 40mm Welding Nozzle
999067	42-406	Welding Nozzle 20mm
999091	42-407	Welding Nozzle 40mm



No. 999091



No. 999075

HAND ROLLER

ITEM #	STYLE #	MATERIAL	WIDTH
999075	11-150	Silicon	1.75 in.



TAPE – THERMO BONDING

Thermo Bonding Tape has a slightly lower melting point than the standard bonding tape. This will allow the user to seal more difficult fabrics. Available in a 7/8 inch width, in white or black.

ITEM #	STYLE #	DESCRIPTION	COLOR	PUT UP	WIDTH
500448	8001	3M Stitchless		100 yd.	7/8 in.
500581		FR	White	100 yd., 12/box	7/8 in.
500582		FR	Black	100 yd., 12/box	7/8 in.